

Design & Access  
Statement  
Volume 1: Outline  
Component  
Part 2 of 2

Hawkins\Brown  
&  
Studio Egret West  
EC.PA.08  
July 2024

# 6 The Illustrative Masterplan

## Testing the Strategic Framework

The Illustrative Masterplan demonstrates one way in which the Strategic Framework could come forward, setting out the ambition and quality of place and character.

This chapter sets out a response to the Strategic Framework and demonstrates how the buildings and landscape have been shaped by the four place pillars to create a cohesive look and feel. It is intended to guide future Plot proposals on the intent of the Strategic Framework and demonstrate the flexibility that is embedded within the Design Code.

This chapter includes:

- A step-by-step guide that shows the relationship of the Illustrative Masterplan to the Control Documents.
- The influence of the four place pillars — nature, innovation, culture and neighbourhood — in defining a unique and specific character for the whole of the masterplan.
- Detailed descriptions of the seven Character Areas and how their public realm, built form and architectural expression could be developed.



# 6.1 The Control Documents

## The Illustrative Masterplan and the Control Documents

The Illustrative Masterplan has been used as a tool to develop the three Control Documents:

- the Parameter Plans
- the Design Code
- the Development Specification

These documents work together to control the relationship between layout, movement, use, amount, scale and appearance.

The Illustrative Masterplan is also a demonstration of how the Control Documents could be applied by testing their robustness and showing what a 'worked example' could deliver.

The Control Documents will be used to define and evaluate building and landscape proposals for future Applications for Reserved Matters Approval (RMA). This process ensures the gradual delivery of one coherent place that delivers on the vision for the Earls Court Site.

► Refer to Application User Guide (EC.PA.05).

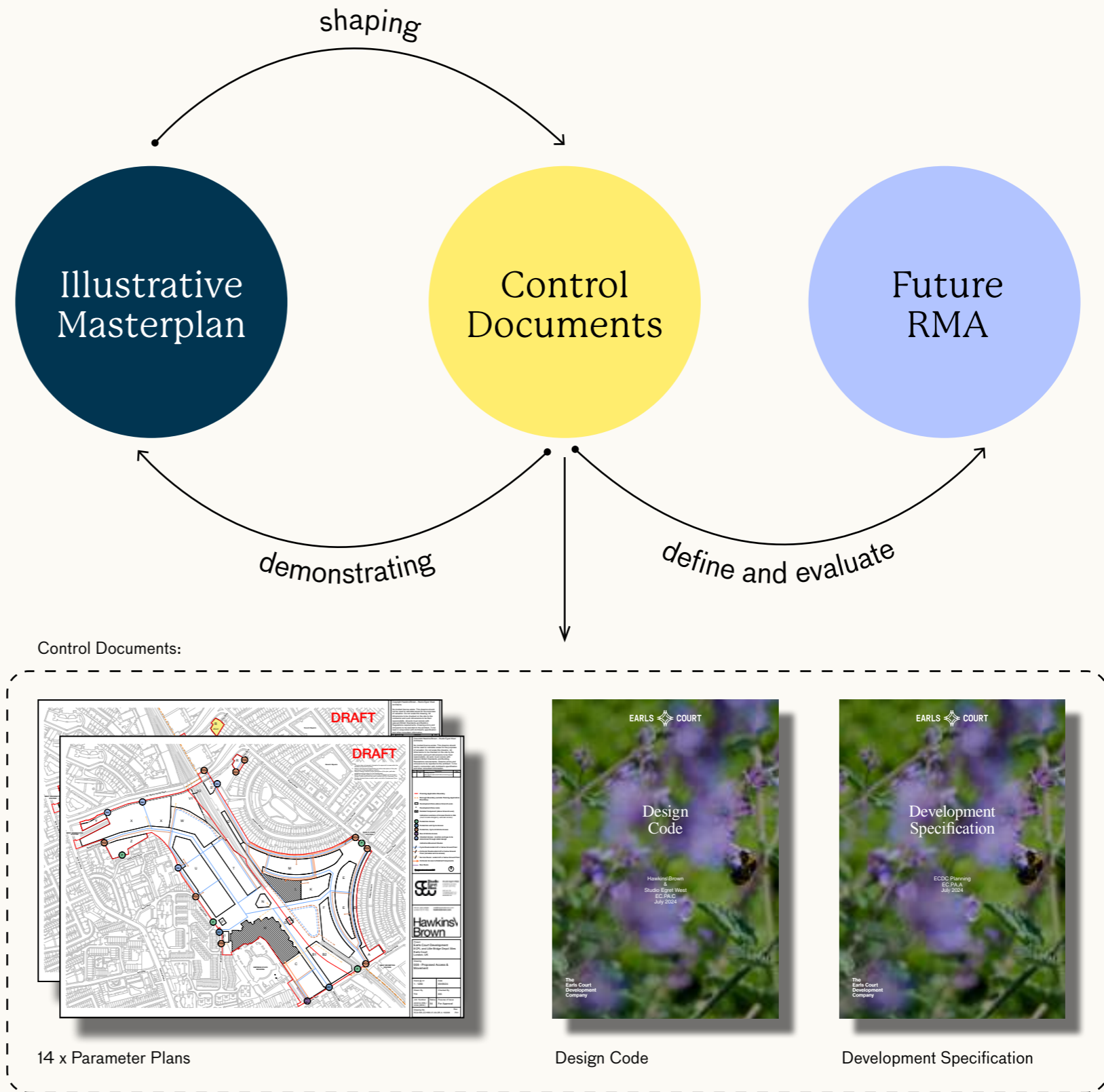

# 6.1 The Control Documents

## The Illustrative Masterplan and the Control Documents

The following diagrams summarise the role of each of the Control Documents in shaping, defining and controlling the scale, use, character and appearance of the Plots.

- ▶ Refer to *Development Specification (EC.PA.A)*.
- ▶ Refer to *Parameter Plans (EC.PA.B)*.
- ▶ Refer to *Design Code (EC.PA.C)*.

### Parameter Plans

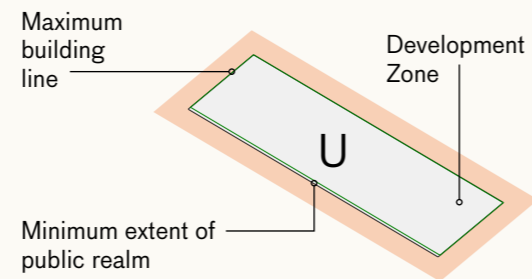

The public realm, Development Zones and maximum building lines are defined in the Parameter Plans.

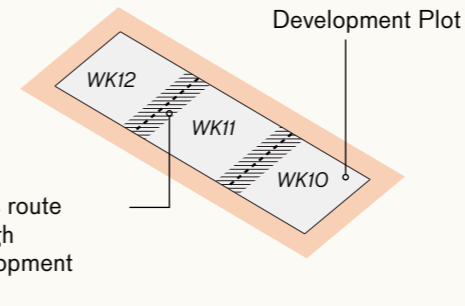

The Plot plan identifies areas where Development Zones will be split into Plots with public routes running through Development Zones.

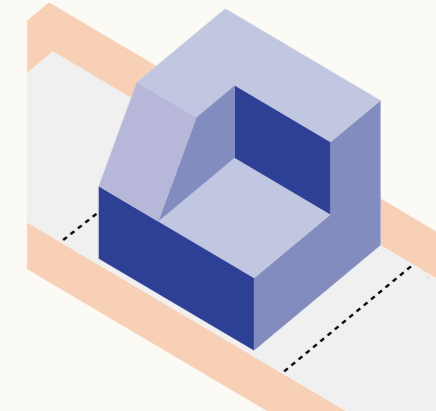

The maximum envelope is a three-dimensional extrusion of the Proposed Maximum Heights Parameter Plan setting the volume for buildings to sit within.

### Development Specification

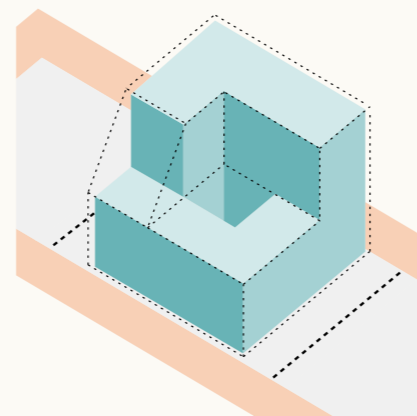

The Development Specification sets the maximum quantum of development for each Development Zone. This amount of floor space can be arranged in any way within the maximum envelope. The balance of different land uses within each Development Zone and Plot is also controlled by the Development Specification.

### Design Code

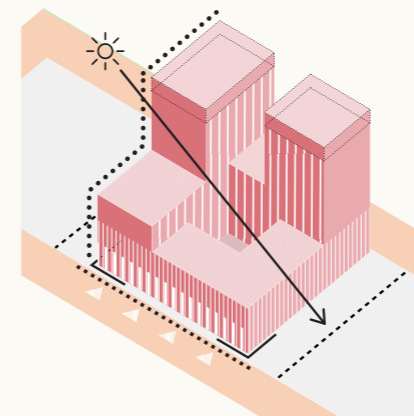

The Design Code defines character and architectural expression, adding a further level of control to the Parameter Plans and Development Specification. This ensures that the ambitions described in this document are delivered in any possible massing and land use scenario.

### Illustrative Masterplan

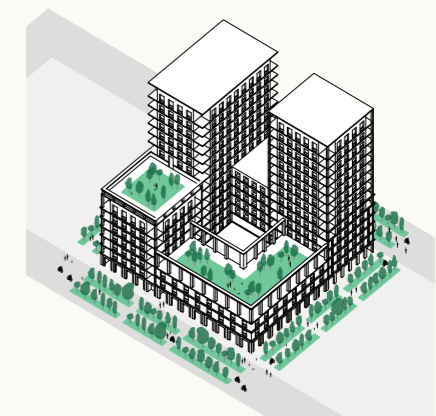

The Illustrative Masterplan is an example of how the development could come forward under the combined effect of the Control Documents. It is a single design response, within a range of possible scenarios, and its aim is to demonstrate what the Proposed Development could look like.

# 6.1 The Control Documents

## The Illustrative Massing and the Maximum Envelope

The maximum envelope is a three-dimensional extrusion of the Proposed Maximum Heights Parameter Plan, establishing the maximum extent of possible development. The illustrative massing sits within the maximum envelope and is one possible development scenario.

A maximum quantum cap is defined in the Development Specification. Together with the rules set out in the Design Code the amount and arrangement of development are controlled to inform future RMAs. This maximum quantum has emerged from and is aligned with the Illustrative Masterplan.

Since any future detailed proposals will be required to sit within the extents defined by the Parameter Plans, the maximum envelope has been used for the Environmental Impact Assessment. However, there will never be a scenario where the entirety of the maximum envelope is developed because the Development Specification and Design Code further reduce and refine the allowable massing.

The Control Documents have been coordinated to offer flexibility for some Development Zones and Plots to allow for a variety of land uses, a range of architectural responses, and space to accommodate future unknowns, at Reserved Matters stage. This flexibility only applies to the Outline Component. The massing and articulation of the Detailed Component is fixed.

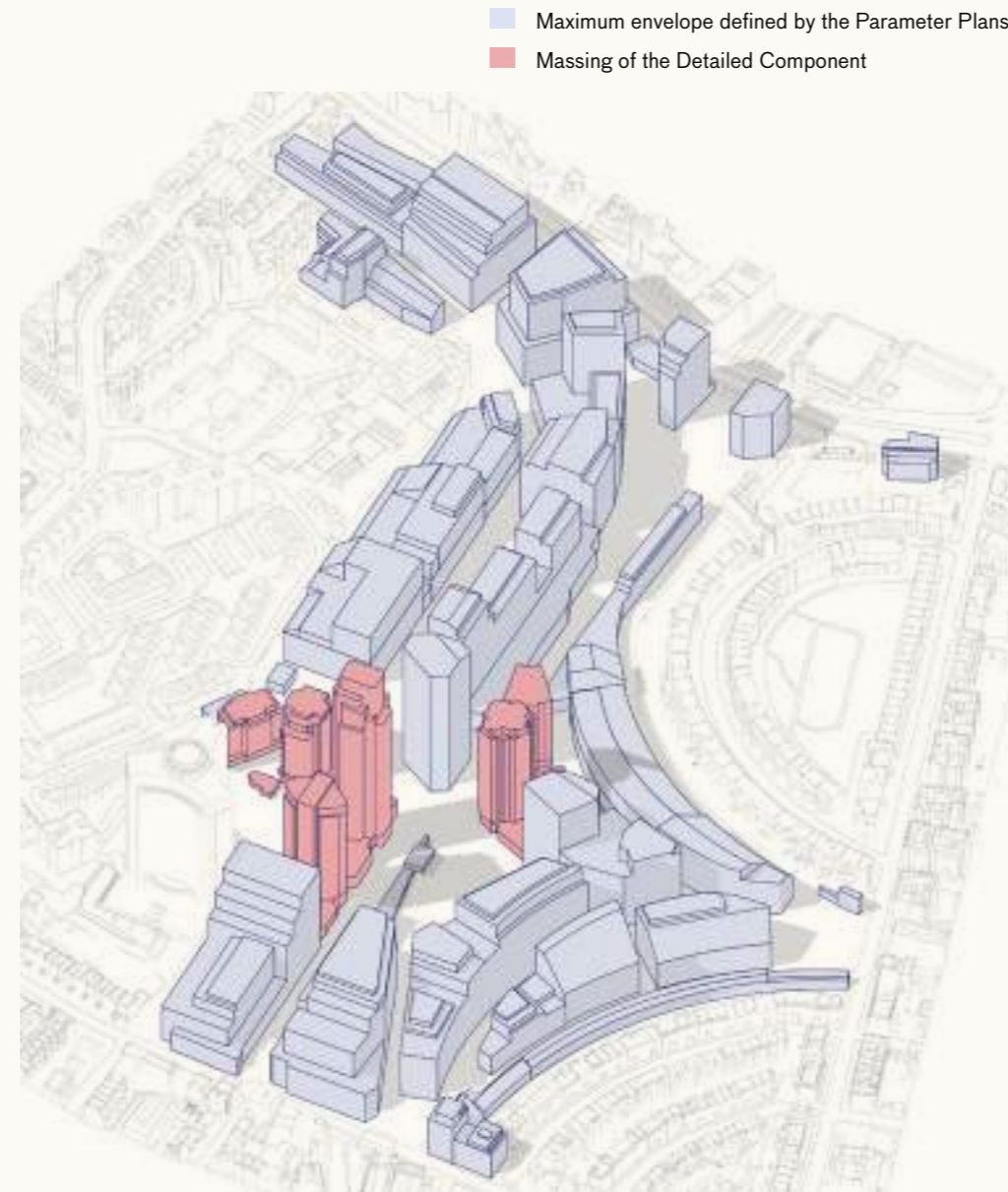

### Maximum Envelope

- Defined by the Maximum Heights Parameter Plan.
- Describes the maximum extent of possible development.
- Used for the Environmental Impact Assessment.
- Maximum envelope - Parameter Plan Drawing 006 - Proposed Maximum Heights is submitted for approval.



### Illustrative Massing

- A possible development massing scenario informed by the Control Documents.
- Gives a possible representation of what could come forward in future Applications for Reserved Matters Approval (RMAs).
- Has informed the Development Specification maximum quantum.
- Not part of the documents for approval.



# 6.1 The Control Documents

## The Illustrative Masterplan and land use distribution

The land use distribution of the Illustrative Masterplan is the envisaged baseline scenario and is the focus of the illustrative material that follows. The Control Documents also make provision for alternative uses from the baseline in certain locations (known as Flexible Plots).

- A number of individual Flexible Plots are able to change from predominantly residential to commercial land use or vice versa.
- Other uses are permitted within some Development Zones as defined in the Development Specification and the Land Use Parameter Plans. This gives flexibility for other uses including social infrastructure, hotel and education if needed in the future, even though they are not part of the envisaged baseline scenario for the Illustrative Masterplan.

Development Zones and Plots with flexibility of use have been selected carefully to ensure future resilience without compromising the spatial principles of the Strategic Framework.

- ▶ Refer to Development Specification (EC.PA.A).
- ▶ Refer to Parameter Plans (EC.PA.B).
- ▶ Refer to Design and Access Statement Volume 1: Outline Component / The Illustrative Masterplan / Flexible Plots (EC.PA.08).

Residential use massing scenario

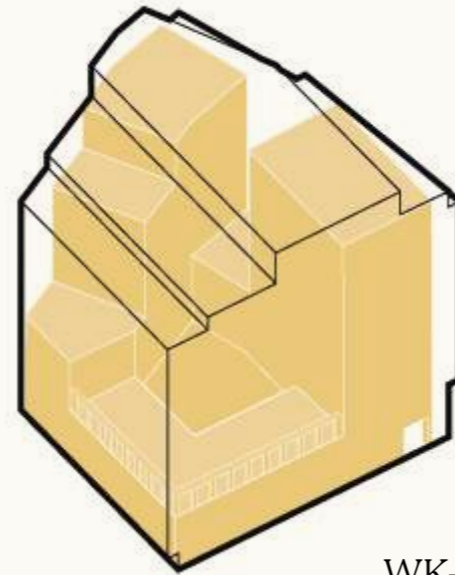

WK-07

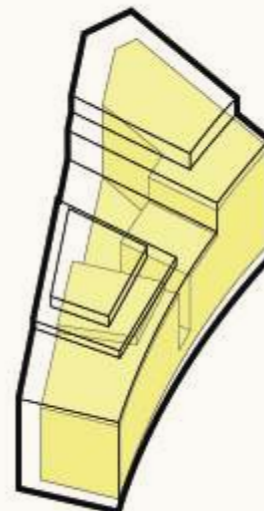

EC-02

Commercial use massing scenario

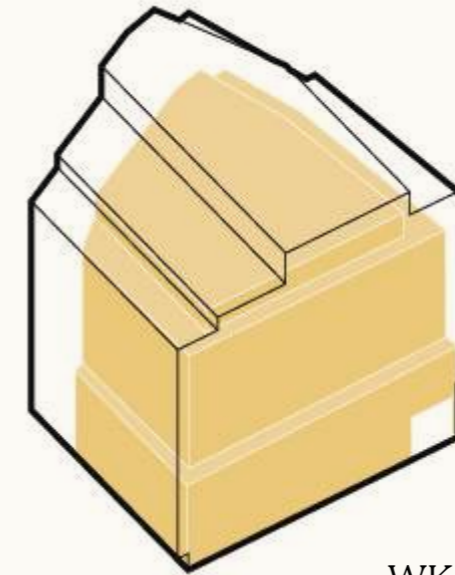

WK-07

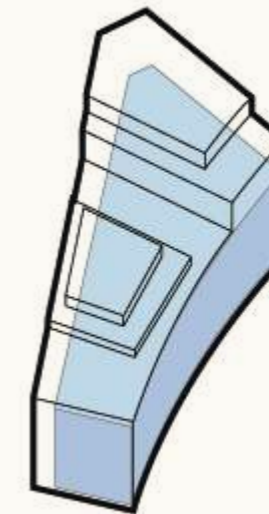

EC-02

- Maximum envelope
- Illustrative massing for residential land use
- Illustrative massing for commercial land use

In Flexible Plots, there is flexibility within the maximum envelope to accommodate massing for different predominant Upper Floor land use scenarios.



# 6.1 The Control Documents

## The Illustrative Masterplan and the Development Specification

The Illustrative Masterplan is an envisaged scenario of development with an associated quantum of development. The Development Specification is a Control Document that defines the maximum quantum of floorspace for each Development Zone.

The Development Specification states a maximum quantum of development that is derived from the Illustrative Masterplan. This has been calculated to provide sufficient flexibility to accommodate a range of uses whilst still upholding the principles of the Strategic Framework. There is no minimum quantum within the Development Specification, however indicative figures have been used to provide support for the Environmental Impact Assessment.

The graphics on this page illustrate the quantum allowances for different types of use within the Development Specification and how this relates to the Illustrative Masterplan.

► Refer to Development Specification (EC.PA.A).

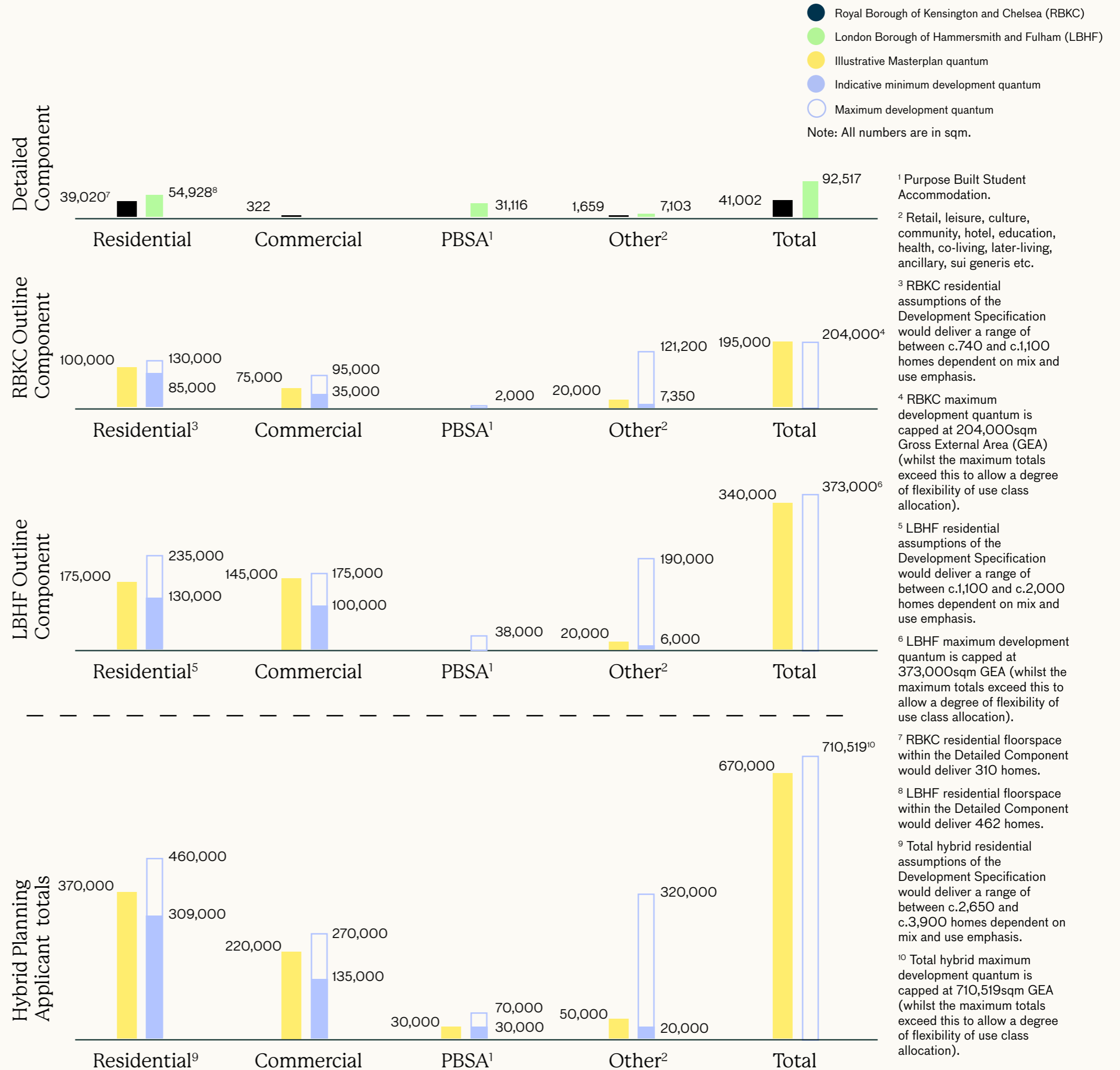





# 6.1 The Control Documents

## The Illustrative Masterplan and the Design Code

The Design Code plays a central role in securing quality, setting out the principles and detailed requirements for the design of the landscape and built form.

The Design Code is intended to ensure that the principles of the Strategic Framework and the Illustrative Masterplan are delivered and reflect the design excellence and quality expected for the Site.

The Design Code provides design rules and guidance that any Application for Reserved Matters Approval (RMAs) would need to comply with if they are to be considered acceptable. There is a single Design Code that covers the whole Site, with individual chapters for each Character Area. The codes for each Character Area cover a range of topics around landscape design, access and movement and architectural characteristics.

This document will ensure that a coherent place is created as future design proposals are brought forward by a range of designers.

► Refer to Design Code (EC.PA.C).

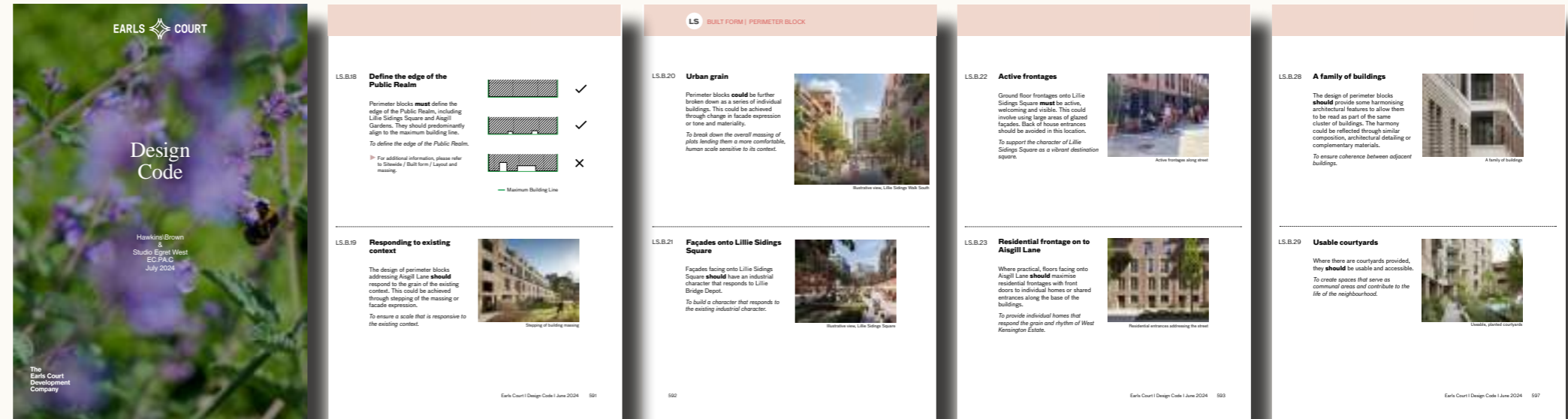

Example pages from the Design Code

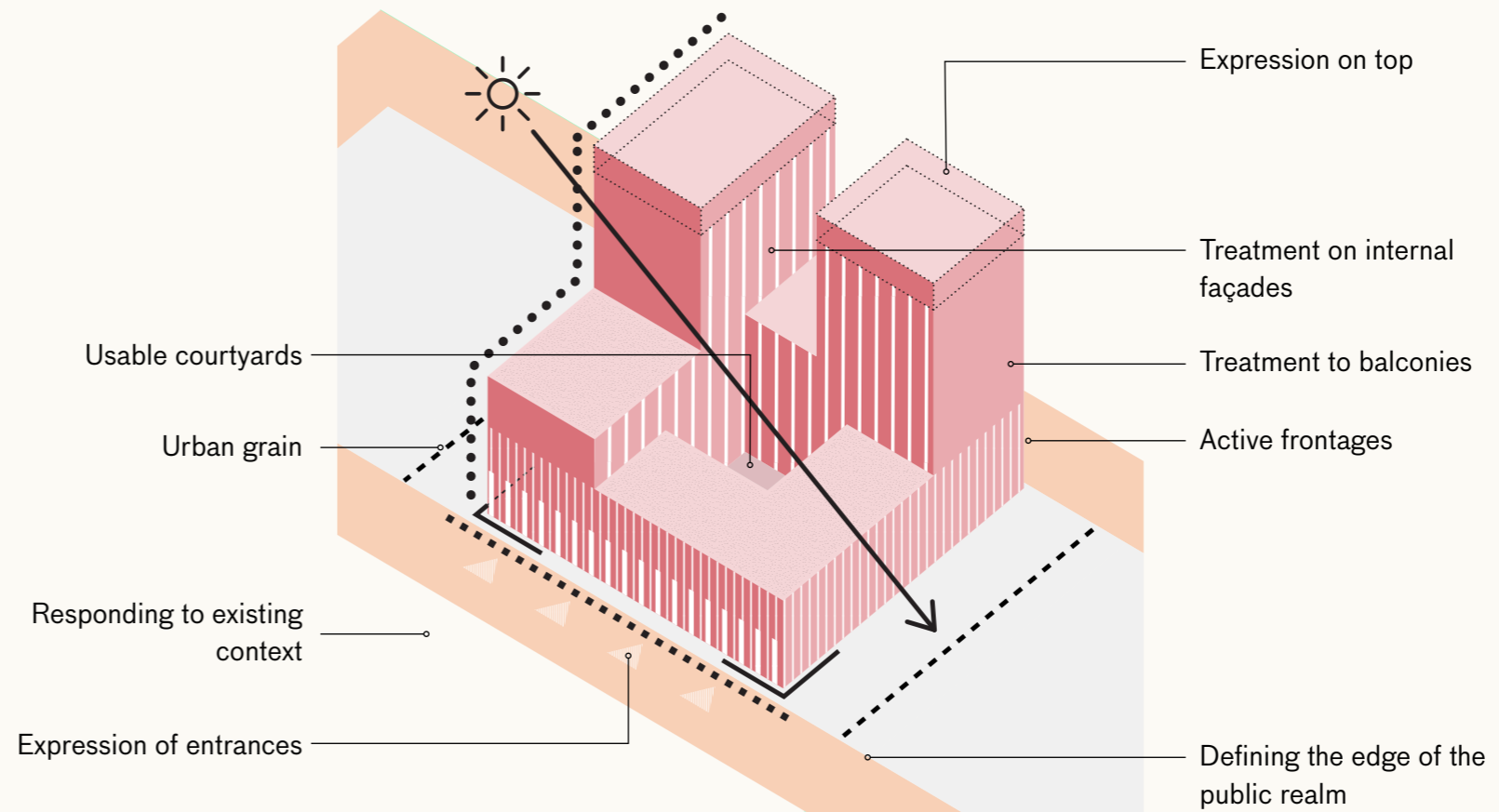

Example diagram showing possible range of design guidance included in the Design Code that might influence the detailed design of a Plot or public space/route at Application for Reserved Matters Approval (RMA) stage.

## 6.2 Overview

### Overview of the Illustrative Masterplan

Earls Court will be transformed into a landscape-led neighbourhood with a diverse mix of spaces, buildings, and uses that holistically create a new vibrant part of West London, a place where people of all ages and backgrounds can come together.

The Illustrative Masterplan demonstrates a thoughtful, coherent response to the Strategic Framework. It is underpinned by the four place pillars of the Earls Court vision:

- A celebration of **nature's** ability to connect and revive
- A showcase for climate and clean **innovation** and skills
- A **cultural** ecosystem for the future of talent
- An inspiring **neighbourhood** designed for all stages of life

The following pages present an overview of how the place pillars and the Design Code could inform the look and feel of the streets, the public spaces, the built form and the uses arrangement within a masterplan proposal.

The Detailed Component of this application has been developed in parallel with the masterplan to ensure its character and qualities align with those of the Illustrative Masterplan.

- ▶ Refer to Design and Access Statement Volume 2: RBKC Detailed Component (EC.RBKC.02)
- ▶ Refer to Design and Access Statement Volume 3: LBHF Detailed Component (EC.LBHF.02)

- ▨ Detailed Component
- Ⓐ RBKC Detailed Component EC05,6
- Ⓑ LBHF Detailed Component WB03,4,5





## 6.2 Overview

### A layered height transition

The massing arrangement of the Illustrative Masterplan responds to the scale of the context by accommodating heights in the centre of the Site and gradually stepping down towards the edges.

Informed by the layers of the Strategic Framework, and defined by the Parameter Plans and quantum of development in the Development Specification, the Illustrative Masterplan demonstrates a design led response to the Site.

An indicative number of storeys have been annotated on the diagram on this page for reference. These are based on assumptions using industry standards for floor-to-floor dimensions as below:

- Ground level typical floor to floor = 4500mm\*
- Residential typical floor to floor = 3150-3300mm
- Commercial typical floor to floor = 4000mm

\*Topographical complexities mean there are exceptions in particular locations.

\*\*Number of storeys are stated from ground floor levels. Where buildings straddle level changes the storey height is typically taken from the main entrance level. Storey heights exclude lower grounds, basements and any roof plant.

On Detailed Components, the number of storeys stated in the Environmental Statement (ES) may differ where it includes basement, lower ground or plant levels.



- X Outline Component storey heights\*\*
- Detailed Component storey heights\*\*



# 6.2 Overview

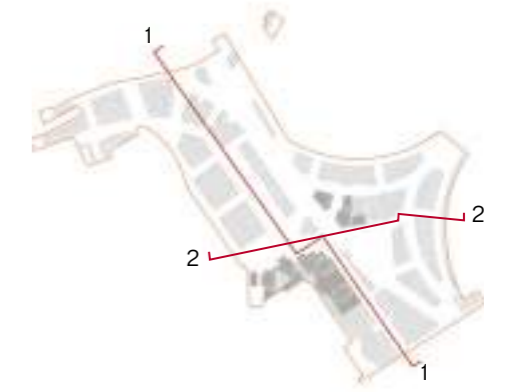

## Illustrative Masterplan sections



Section 1: Long section/elevation from Cromwell Road to Lillie Road, through Lillie Sidings Square and Empress Place Boulevard

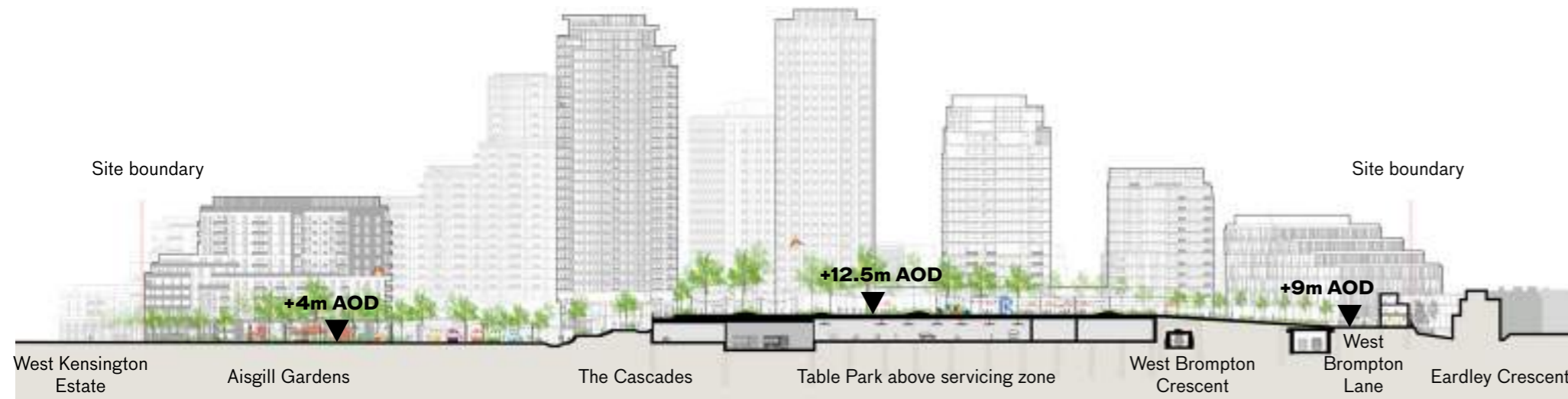

Section 2: Cross section/elevation across the Site, from West Kensington Estate to Eardley Crescent



The sections describe the level changes across the Site, the stepped approach to height from the Site's edges and the location of below ground infrastructure.



## 6.2 Overview

### A celebration of nature's ability to connect and revive

Inspired by Earls Court's history of horticulture, pleasure gardens and showcase, a series of Exhibition Gardens creates a landscape full of discovery and surprise.

Each public open space has an important role to play within the landscaped network. Conceived as a series of Exhibition Gardens, the different spaces respond to their location and context, whilst allowing people to move through the Site intuitively. Each garden reinforces the qualities of its respective Character Area, as described later in this chapter.

The unique character and identity of each space informs the approach to biodiversity but also demonstrates the numerous ways in which people and nature can coexist.

This is reflective of the sitewide Design Code principles.

► Refer to Design Code / Spaces and Routes (EC.PA.C).



## 6.2 Overview

### A showcase for climate and clean innovation and skills

Making the most of connectivity to the Site, three workspace clusters are located adjacent to each of the stations and are linked together by the north-south and east-west routes through the Site.

The three workspace clusters create a home for the fast-growing climate tech market with a variety of space to support start-ups, scale-ups and multinational companies. These are located:

- At Empress Place, a campus of four buildings that can suit a variety of tenancy arrangements and create an address to Lillie Road.
- At West Kensington, the buildings are scaled to respond to the context of West Cromwell Road, marking a major arterial route into Central London and providing opportunities for multinational companies and headquarter workspaces.
- At Warwick Square, a pair of commercial workspace buildings, similar in form, and with complementary architectural expression, frame the square and main route to the Table Park from Earl's Court station.

Each cluster is located within a five minute walk of a station. The streets and public realm are lined with shops, cafés and restaurants for workers to use. Alongside the Exhibition Gardens and flexible cultural venues, Earls Court will become a centre for innovation and skills.

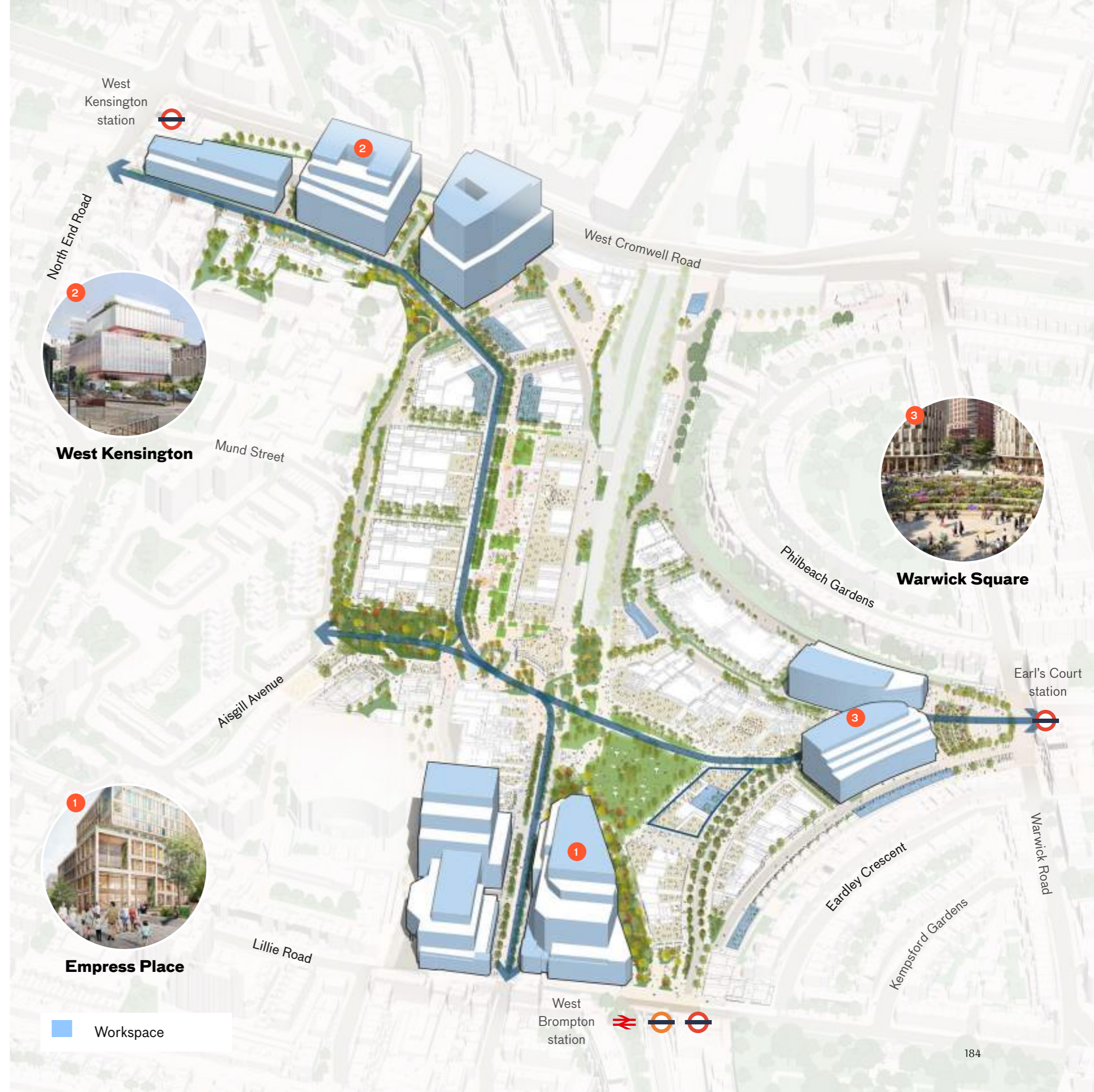



## 6.2 Overview

### A cultural ecosystem for the future of talent

The legacy of culture is brought to life with a series of cultural hubs for performance, production and immersive experiences.

Three cultural hubs are located at key destination points around the Site. Each hub includes an anchor venue as well as smaller spaces to support the production of culture and opportunities for seasonal events within the public realm. This could include the following:

- Lillie Sidings allows for a flexible immersive venue alongside a food destination within the re-purposed Train Shed.
- Empress Place contains a destination flexible auditorium with entrances from the boulevard and the Table Park level.
- West Brompton Crescent can accommodate a venue for performance of live music alongside other events.

These cultural venues are linked by active streets designed to create an economy for local shops and restaurants to benefit from the footfall generated. Retail uses are primarily located along West Brompton Crescent, where there is potential for independent businesses to complement the offer already established by nearby high streets. Restaurants, cafés and bars are concentrated on the edge of the Table Park and Lillie Sidings Square, taking advantage of opportunities for al fresco dining and activating the spaces into the evenings and weekends.



#### Lillie Sidings

Potential for an immersive venue for approximately 900 people standing and 500 people seated.



#### Empress Place

Potential for a multi-use auditorium, for approximately 1,000 people standing and 600 people seated.



#### West Brompton Crescent

Potential for a flexible music venue for approximately 750 people standing and 400 people seated.



## 6.2 Overview

### An inspiring neighbourhood designed for all stages of life

Reflective of the diversity of London, a range of building types and tenures promotes an accessible and inclusive neighbourhood of homes for all.

A variety of residential typologies are accommodated in the Illustrative Masterplan. Each type is reflective of its context and the Character Area within which it is located. This could include the following:

- Townhouses at the eastern edge relate to the existing crescent terraced houses and can accommodate families.
- Homes in taller buildings on the edge of the Table Park offer city wide views with the buzz of culture, retail and food and drink at the base, suiting market sale and student accommodation.
- Courtyard blocks have generous shared external amenity spaces where children can play and older people can relax.
- Mid-scale buildings reflect the character of the mansion blocks in the local area and could offer purpose built accommodation for later living or flats for all ages.

A new Community Hub (4) is located on in the base of the Detailed Component WBO5, which will reprove some of the facilities available at the existing Community Hub. There will also be a nursery opening onto the Table Park. Additional social infrastructure facilities, like a potential community hall, will be included in future phases of the project to serve the existing and emerging communities.

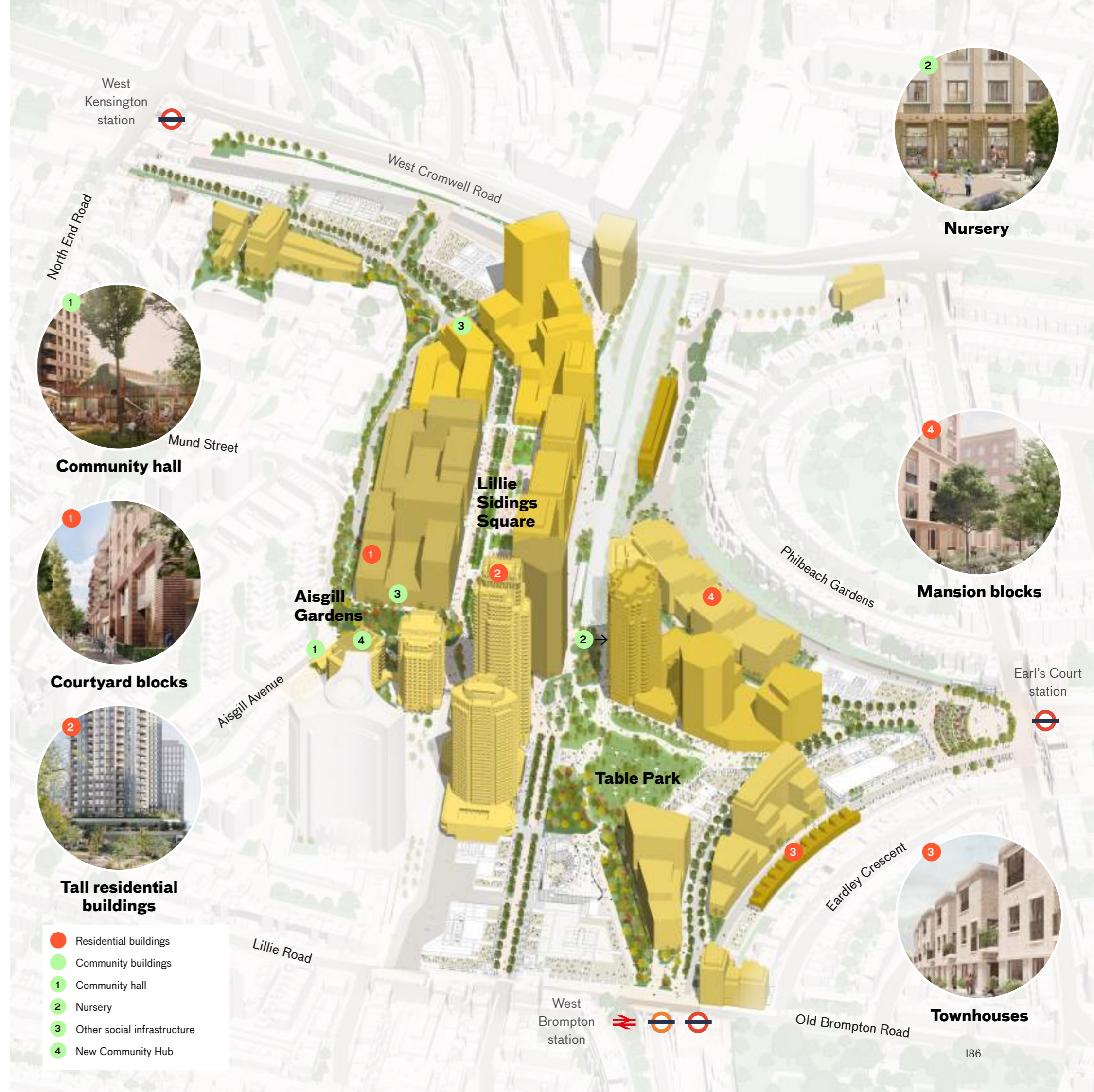



# Illustrative Masterplan



West Kensington station

Earls Court station

West Brompton station

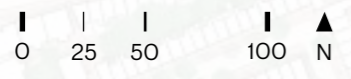

■ Detailed Component



# 6.3 Character Areas

## Seven Character Areas

The Illustrative Masterplan demonstrates how the built form and public realm proposals could come forward for each of the seven Character Areas, as set out in the Control Documents.

Ranging from quiet residential streets to bustling cultural anchors, the Character Areas connect around the central open space of the Table Park and respond to the existing neighbourhoods along their edges.

The information on the following pages provides an illustrative proposal for each of the Character Areas. Each proposal demonstrates how the distinctive qualities described in the Design Code could be realised into a future design proposal.



# 6.3 Character Areas

## A guide to the Character Area illustrative proposals

Each Character Area is introduced with an illustrative image and an overview, followed by an illustrative design response that demonstrates how architectural quality, character, articulation and appearance could come forward in line with the Design Code and other Control Documents.

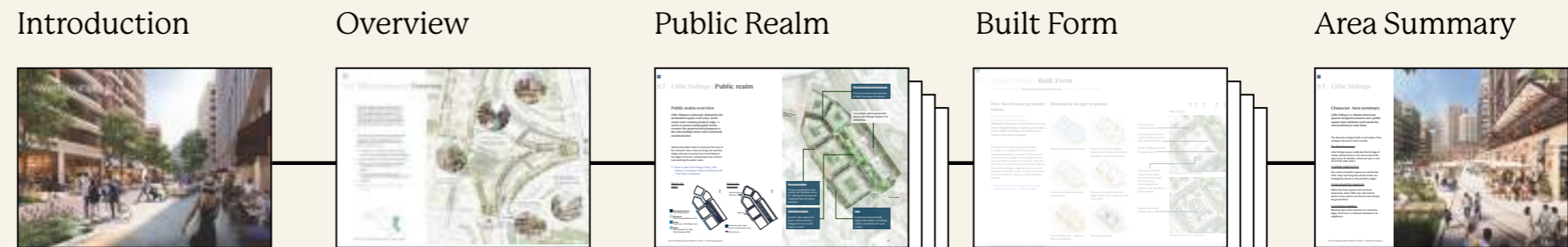

Illustrative Plot testing has been undertaken by four architectural practices alongside the lead masterplanning Design Team, demonstrating how a variety of design approaches could come together within the structure of the framework to deliver a holistic neighbourhood.

A summary of alternative use scenarios for Flexible Plots can be found at the end of this chapter.

### 1) Illustrative design response



Each Character Area, space and Plot is distilled into a series of key principles that build upon the Strategic Framework and respond to the Design Code and Parameter Plans.

### 2) Illustrative Plot testing



Each Plot has been developed with an indicative layout to verify ground and upper level uses are achievable within each footprint.

The layouts have been developed to an outline level of detail for the sole purpose of illustrating the masterplan in the Hybrid Applications. The Outline Plots will be revisited and developed by a number of different architects to inform Applications for Reserved Matters Approval.

In residential Plots a combination of unit types are shown but there is no commitment to a particular mix at this stage.

### 3) Precedents and visualisation



Precedent imagery is used throughout the chapter to give examples of the type of landscape or architecture that is intended in the proposals. The caption of the image describes which aspect of the precedent is relevant.

Visualisations have been produced by the Design Teams to illustrate the designs in the context of the wider proposals and to communicate the potential look and feel.



# West Brompton





# 6.4 West Brompton | Overview

West Brompton is a lively quarter that connects Earl's Court station to West Brompton station. It is anchored by a leafy crescent lined with shops, cafés and restaurants that ensure it is active during the day and into the evening.

This section illustrates how the Character Area has been developed alongside the Control Documents. Key principles that characterise West Brompton are set out on the image on the right.

► Refer to Design Code / West Brompton (EC.PA.C).

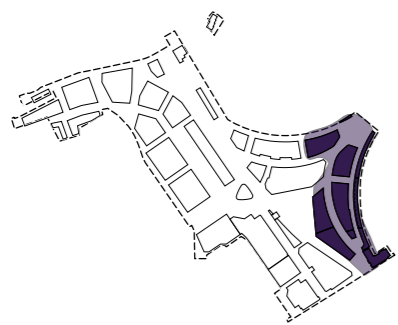

Location of West Brompton Character Area

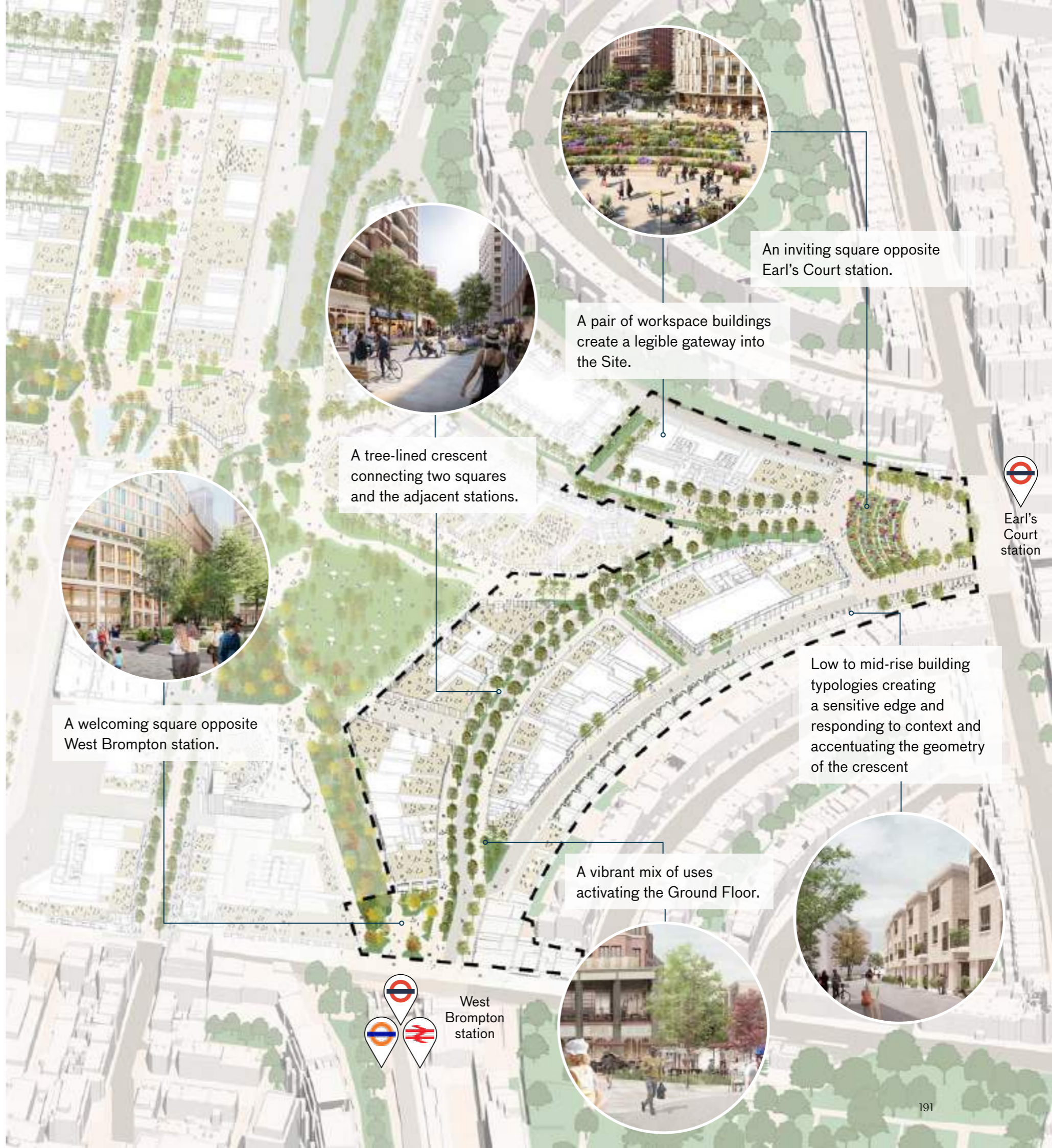

An inviting square opposite Earl's Court station.

A pair of workspace buildings create a legible gateway into the Site.

A tree-lined crescent connecting two squares and the adjacent stations.

A welcoming square opposite West Brompton station.

Low to mid-rise building typologies creating a sensitive edge and responding to context and accentuating the geometry of the crescent

A vibrant mix of uses activating the Ground Floor.



West Brompton station



Earl's Court station



# 6.4 West Brompton | Public Realm

West Brompton features two welcoming squares that mark entrances from nearby stations. They are connected by West Brompton Crescent and West Brompton Lane, two gently curving and pedestrian-focused streets.

Key spaces and routes are outlined in the Control Documents including:  
Spaces and routes

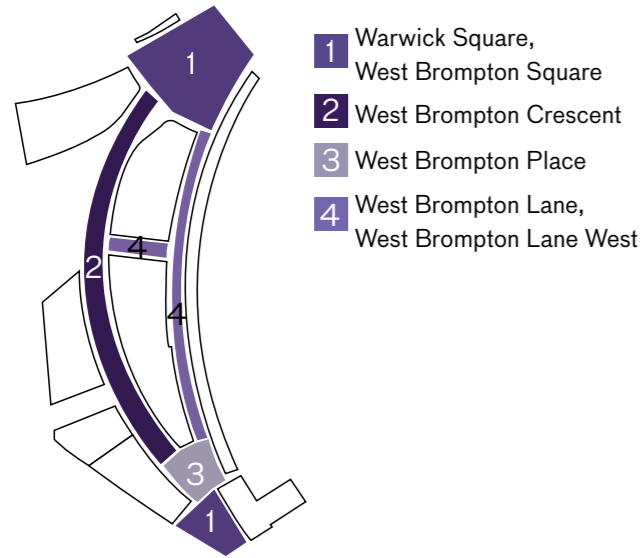

Access and movement

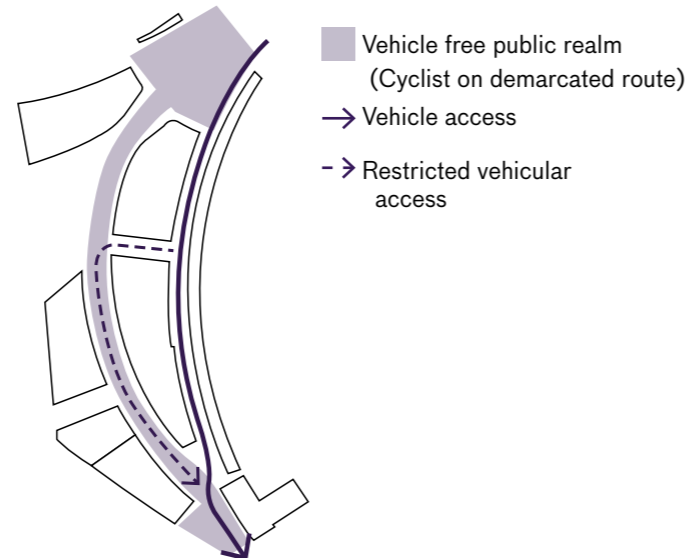

▶ Refer to Design Code / West Brompton / Landscape / Spaces (EC.PA.C).

▶ Refer to Design Code / Sitewide / Landscape (EC.PA.C).



# 6.4 West Brompton | Public Realm

Squares | Crescent | Place | Lanes

## Warwick Square

Warwick Square is a welcoming arrival from Earl's Court station that reimagines the iconic steps of the former Exhibition Centres into a unique Flower Amphitheatre, encouraging people to meet, rest and gather.

The illustrative proposals for Warwick Square are informed by the RBKC Placemaking Framework and responds to key principles set out by the Control Documents including:

- Drawing inspiration from the arrival to the original Exhibition Centres.
- Designing with a flower-rich approach, that supports the sitewide biodiversity strategy.
- Framing the square with trees to create a sense of enclosure.
- Providing a space to congregate and gather encouraging people to dwell in the square.
- Activating frontages along the square to enliven the public realm.

- ▶ Refer to Design Code / West Brompton / Landscape / Warwick Square (EC.PA.C).
- ▶ Refer to Design and Access Statement Volume 1: Outline Component / Appendices / RBKC Placemaking Framework Tracker (EC.PA.08).

## Illustrative design response



Illustrative plan of Warwick Square

A flexible space designed to host temporary events and activities such as a Christmas tree display, a bandstand, or a performer's stage.

Square framed by trees with high canopy clearance to allow clear views into the space.

The former Exhibition Centres steps are reimagined through the creation of a Flower Amphitheatre.

Active frontages face onto the square animating the public realm.

Vehicular access restricted to the edges of the square along Warwick and West Brompton Lane.



The Flower Amphitheatre is framed by trees



Stepped and terraced flower beds form the amphitheatre

### Key design principles

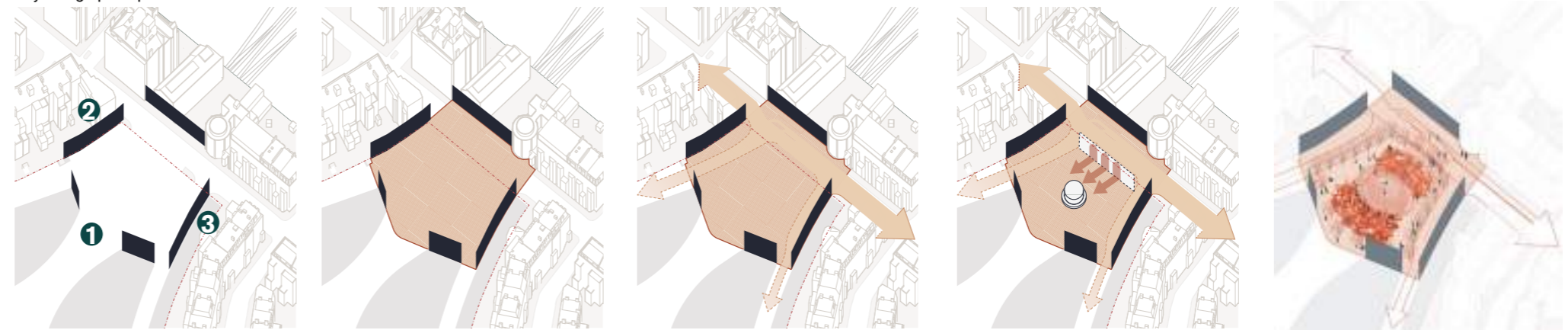

Framing - The space is framed by proposed development façades

Clear platform - Extends the sense of place

Access and roads - Existing road conditions define the northern part of the square

Focal Beacon - A focal centre point can become integral to the structure of the square

Exhibition Centres steps are inverted and planted, as a Flower Amphitheatre



# 6.4 West Brompton | Public Realm

Squares | Crescent | Place | Lanes

## Structural constraints

Existing structures and the 1930s Underground tunnel roof running underneath the Site define loading constraints and inform the design of Warwick Square.

A site-specific response to the constraints of the below ground infrastructure includes:

### Creating gentle slopes for universal pedestrian access

- The existing surface will need to be carefully altered to not interfere or compromise the structure underneath.

### Soil depth

- Loading limitations over the Underground tunnels constrain the soil depth, location, and capacity of planting.
- Larger trees are located along the edges of the square, where full soil depth is achievable.
- Flowers, grasses and perennials are located over the tunnel in areas that require less soil build up.

▶ Refer to Design Code / West Brompton / Landscape / Warwick Square (EC.PA.C).



Structural schematic over the existing structure at Warwick Square

- No additional loading afforded
- 200 mm soil depth allowed
- 500 mm soil depth allowed
- Full soil depth allowed

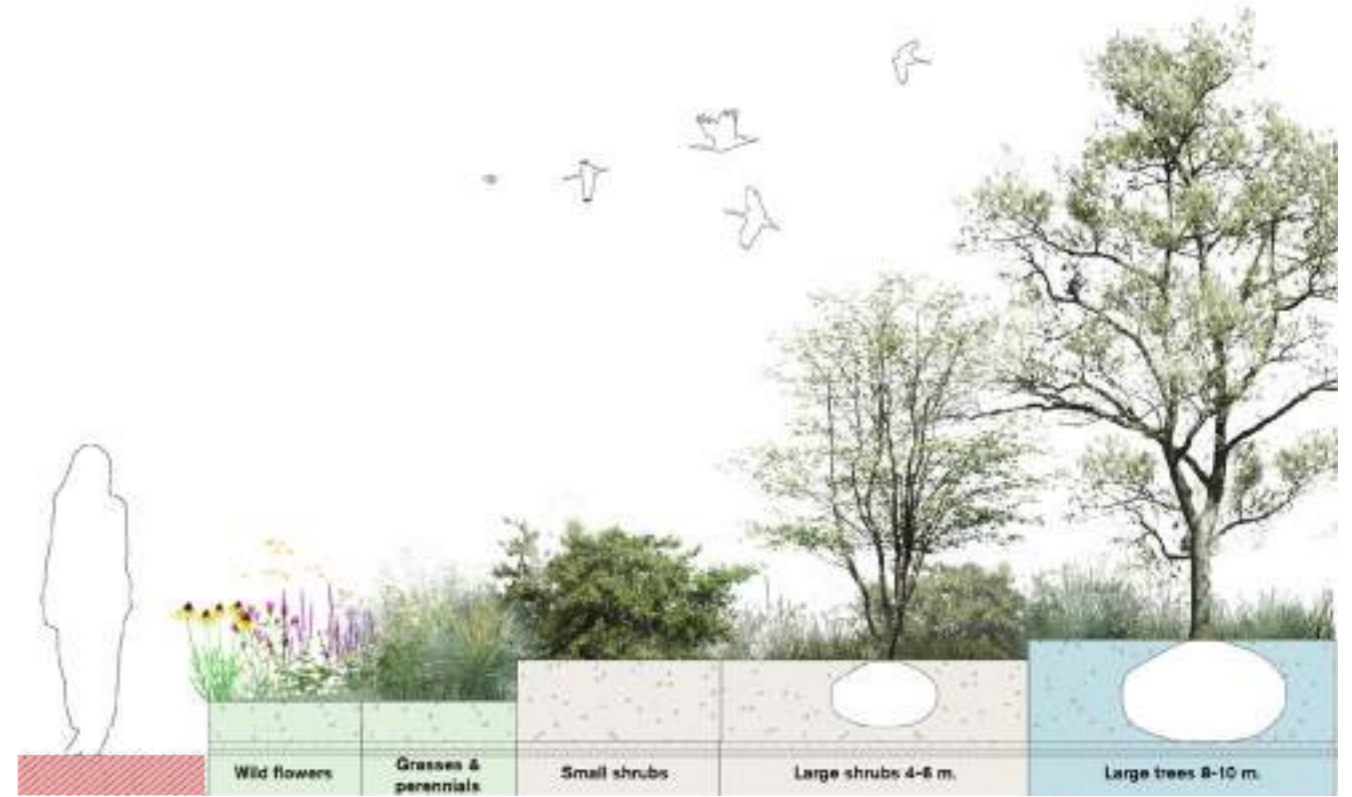

Diagrammatic section showing planting depths and the planting types they can accommodate

200 mm soil depth  
Flowers, grasses and perennials

350-670 mm soil depth  
Shrubs and small trees

Full soil depth  
Trees

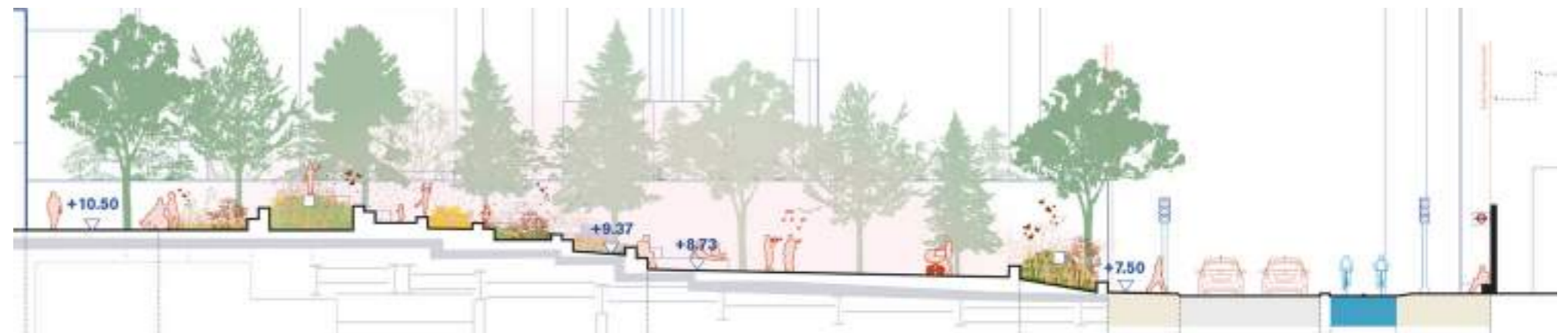

Illustrative section through Warwick Square and Warwick Road





## 6.4 West Brompton | Public Realm

Squares | Crescent | Place | Lanes



Key plan

### Warwick Square

### Illustrative design response

The key principles that characterise Warwick Square are described in the Design Code. These are demonstrated in the illustrative proposal shown in the image, including:

- 1 Celebrating the Site's history**  
The Exhibition Centres steps are reimagined as a Flower Amphitheatre and seasonal garden, defining Warwick Square's distinct identity.
- 2 Providing universal access**  
Universal access addresses the Site's level change and is provided along both sides of the square.
- 3 Creating a sense of enclosure**  
The square is framed by trees that create a sense of enclosure and a clear definition between pedestrian and vehicular areas.
- 4 Providing a space for gathering**  
The flexible central space in the square becomes a focal point for curating temporary events or public art.
- 5 Activated Façades**  
Façades facing the square are activated at the Ground Floor, animating the public realm.

► Refer to Design Code / West Brompton / Landscape / Warwick Square (EC.PA.C).



Aerial view showing the Flower Amphitheatre at Warwick Square



# 6.4 West Brompton | Public Realm

Squares | Crescent | Place | Lanes

## West Brompton Square

West Brompton Square brings together the character of the active retail crescent, the natural and biodiverse environment of the Bioline\*, and the busy footfall from the station entrance.

The proposals are informed by the RBKC Placemaking Framework and responds to key moves set out by the Control Documents, including:

- Developing a composite space incorporating three overlapping functions; the Bioline\*, the vibrant crescent and pedestrian connectivity.
- Creating a cohesive landscaped approach with rich planting to unify the multifunctional space.
- Connecting to areas of ecological value such as Brompton Cemetery and the West London Line, which is a Site of Importance for Nature Conservation (SINC).
- Providing access and movement distributed along key desire lines.

\*Decking over of the West London Railway Line (the Bioline) is subject to agreement with third party land owners.

▶ Refer to Design Code / West Brompton / Landscape / West Brompton Square (EC.PA.C).

## Illustrative design response

- Extending ecological habitats from the SINC.
- Framing a central space with a variety of planting.
- A primary gateway into the Site.

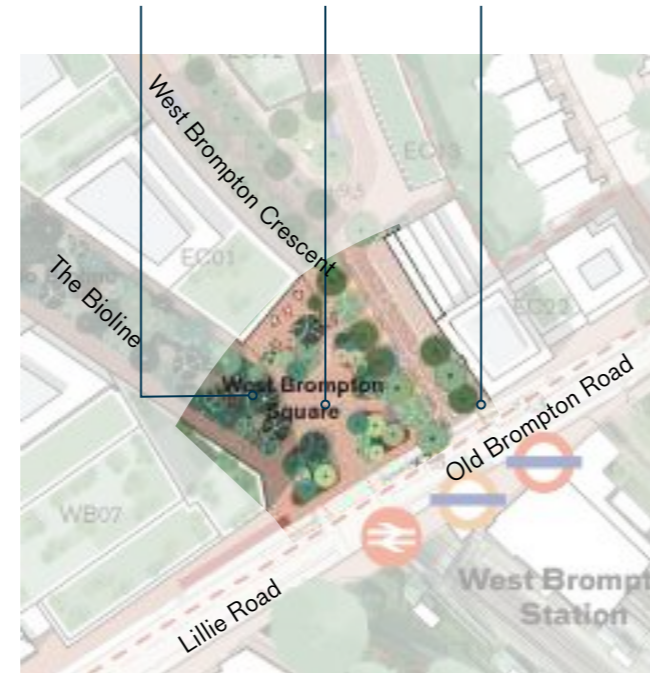

Illustrative plan of West Brompton Square



Illustrative eye-level view of West Brompton Square



Framed by built form



Complemented by access



Characterised by landscaping



# 6.4 West Brompton | Public Realm

Squares | Crescent | Place | Lanes

## Structural constraints

Existing underground tunnels converge beneath the square and their structural capacity informs the design of West Brompton Square.

A site-specific response to the constraints of the below ground infrastructure should consider:

- The potential for a new structure over the West London Line allowing for more soil depth.
- Providing access from West Brompton Square to the Bioline\* and West Brompton Crescent.
- Integrating raised planters that do not conflict with the structure underneath.
- Raised planting beds with integrated inclusive seating, framing routes and spaces.
- Generous planting to create a healthy street experience.

\*Decking over of the West London Railway Line (the Bioline) is subject to agreement with third party land owners.

► Refer to Design Code / West Brompton / Landscape / West Brompton Square (EC.PAC).



Structural schematic over the existing Apron at West Brompton Square

- Adequate soil depth above structure provided
- Mounding or raised planters required to achieve adequate soil depth

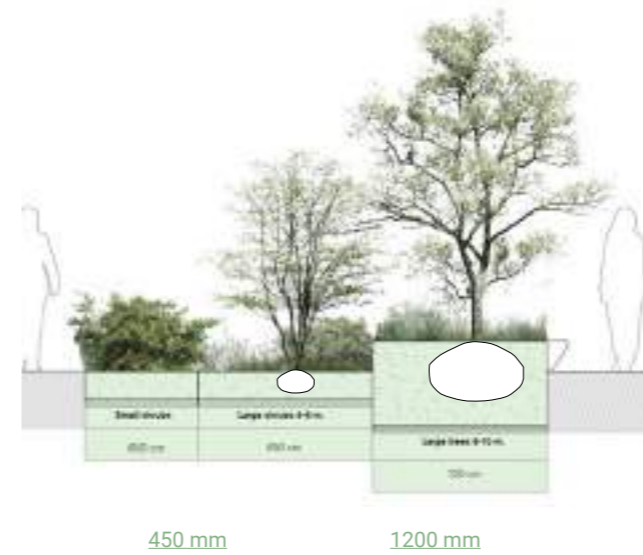

Indicative section showing planting depths where there is sufficient soil build up allowed.

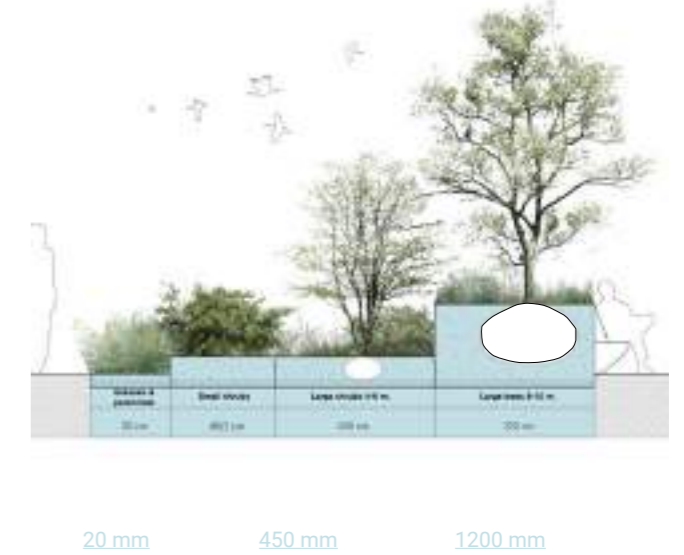

Indicative section for mounding up of planting with soil depth is constrained.

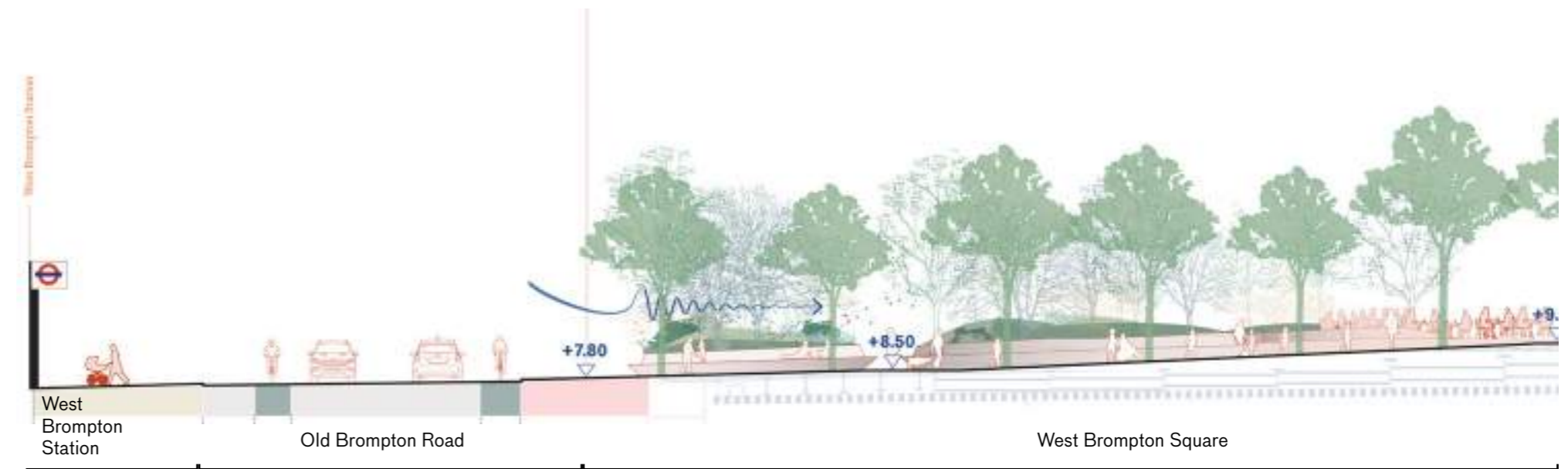

Illustrative section through West Brompton Square and Old Brompton Road



# 6.4 West Brompton | Public Realm

Squares | Crescent | Place | Lanes

## West Brompton Square

The key principles that characterise West Brompton Square are described in the Design Code. These are demonstrated in the illustrative proposal shown in the image, including:

- 1** Creating a multi-functional and familiar space  
Planting, seating and paving give the square its own character whilst unifying the various functions, uses and connections around it.
- 2** Connecting green corridors  
The Bioline over of the West London Railway Line creates a potential opportunity to extend an existing ecological corridor into the Site.
- 3** Enabling uses that spill-out onto the Square  
Ground floor spill-out zones activate the public realm.
- 4** Planting that fosters a sense of enclosure  
Planting beds define and contain the central space.
- 5** Improving Lillie Road  
Street improvements and pavement widening allow safer access to the Site and surroundings.

► Refer to Design Code / West Brompton / Landscape / West Brompton Square (EC.PA.C).



Key plan

## Illustrative design response



Aerial view showing West Brompton Square and the Bioline meeting Lillie Road and Old Brompton Road

# 6.4 West Brompton | Public Realm

Squares | Crescent | Place | Lanes

## West Brompton Crescent Illustrative design response

West Brompton Crescent is a lively retail street connecting Warwick and West Brompton Squares. The people-first design enables pedestrians to move freely in a clean, healthy and safe environment lined with cafés and shops.

The key principles that characterise West Brompton Crescent are described in the Design Code. These are demonstrated in the illustrative proposal shown in the image, including:

- Drawing from familiar high street and crescent typologies in the area.
- Enhancing the public realm as a predominantly vehicle-free environment.
- Creating an emphasis on planting with trees and biodiverse green/blue infrastructure.
- Allowing for a diversity of shop fronts, such as local retail, boutique shopping, dining, and cultural uses.

► Refer to Design Code / West Brompton / Landscape / West Brompton Crescent (EC.PA.C).

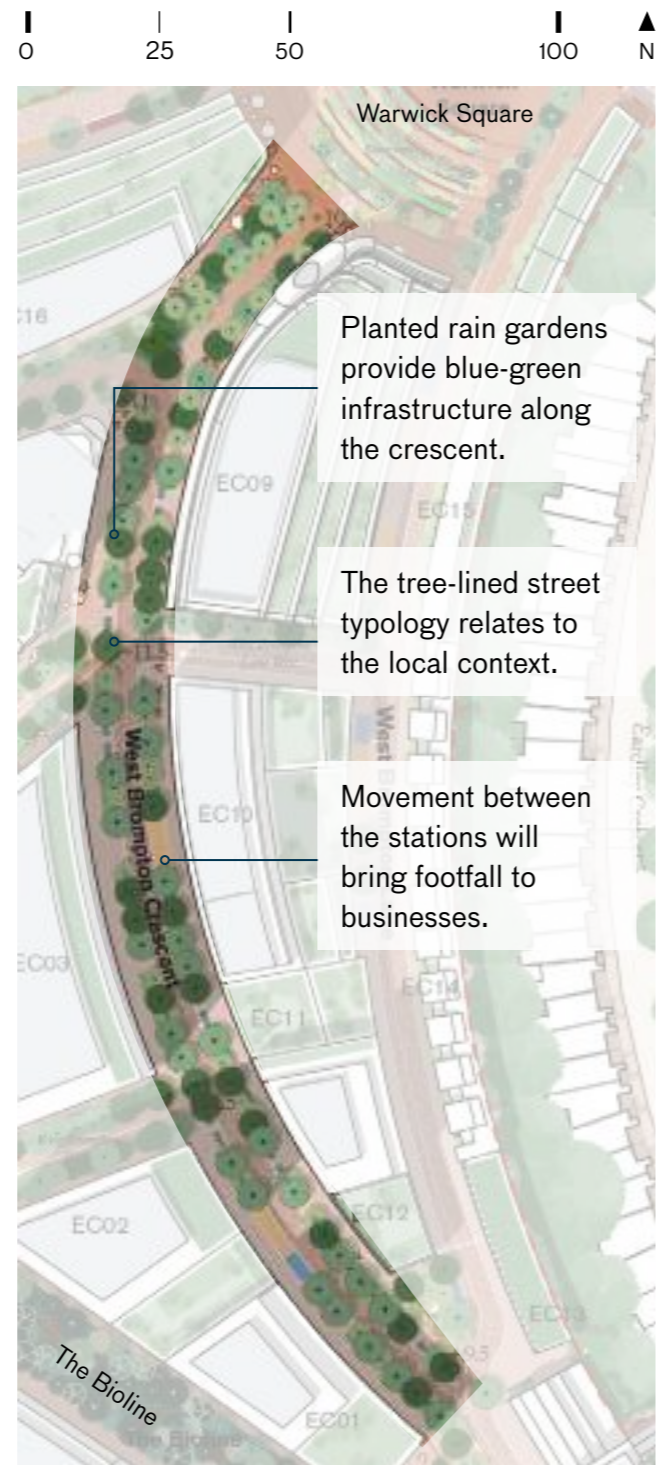

Illustrative plan showing West Brompton Crescent



Seating within the public realm allows people to dwell. Lighting columns illuminate the street and Ground Floor activity. A central route for pedestrians, cyclists and the occasional vehicle. Pedestrian only footpath on the edges.

Illustrative section through West Brompton Crescent



Shop front design creates a lively and active shopping street that echoes other Central and West London streets



Spill-out from cafés and restaurants activate the street.



# 6.4 West Brompton | Public Realm

Squares | Crescent | Place | Lanes

## West Brompton Place

West Brompton Place is an intimate pocket space that completes the character of West Brompton Crescent and Lane. It features a small prow building with a café spill-out space at its base.

The key principles that characterise West Brompton Place are described in the Design Code. These are demonstrated in the illustrative proposal shown in the image, including:

- Creating a transition space between West Brompton Square, Crescent and Lane.
- Creating continuity from the crescent and lane to define legible vehicular, pedestrian and cycle routes.

► Refer to Design Code / West Brompton / Landscape / West Brompton Place (EC.PA.C).

## Illustrative design response

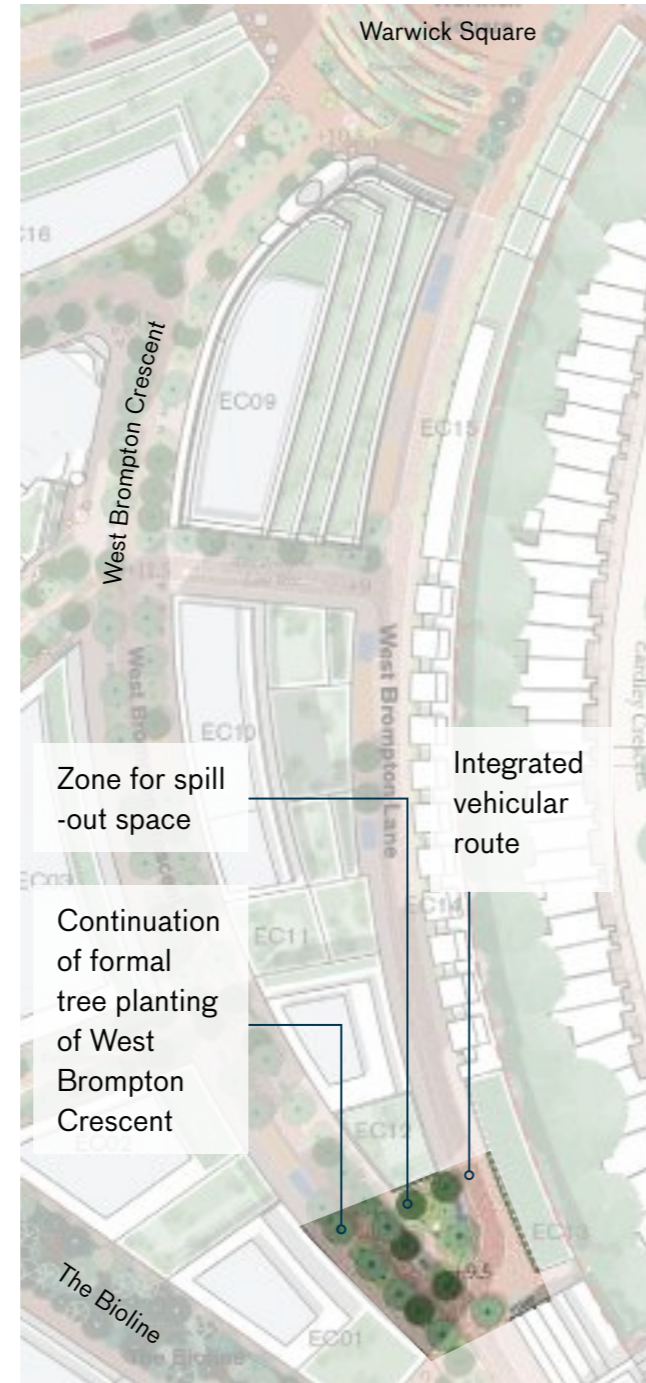

Illustrative plan showing West Brompton Place



View of West Brompton Place from the southern end of West Brompton Crescent.



# 6.4 West Brompton | Public Realm

Squares | Crescent | Place | Lanes

## West Brompton Lane

West Brompton Lane is a quiet residential street framed by townhouses and workspaces, and designed to accommodate pedestrian and vehicle movement from Warwick Road to Old Brompton Road.

The key principles that characterise West Brompton Lane are described in the Design Code. These are demonstrated in the illustrative proposal, including:

- Creating a one-way vehicular route and defined zones for pedestrians and cyclists.
- Planting a linear arrangement of trees, interspersed between parking and loading bays.
- Uniform materiality to reflect the local character of similar streets.

► Refer to Design Code / West Brompton / Landscape / West Brompton Lane (EC.PA.C).

## Illustrative design response

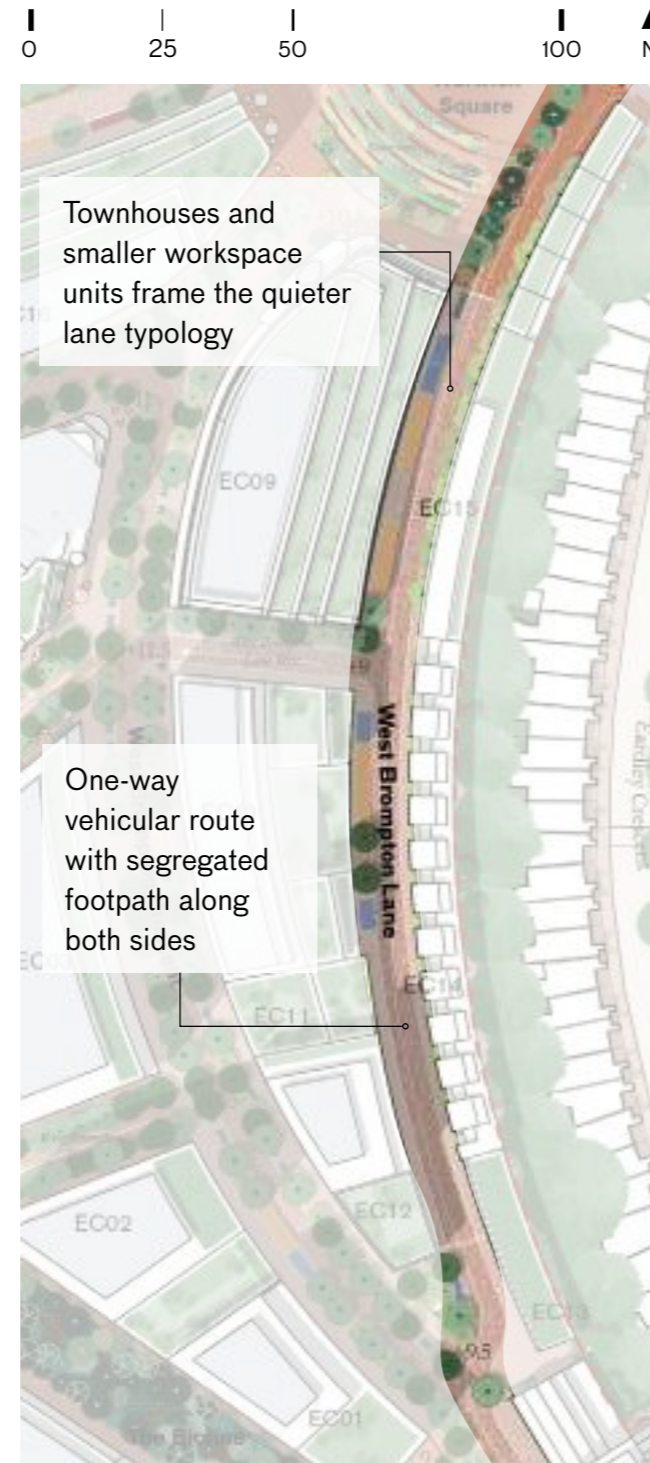

Illustrative plan showing the West Brompton Lane



Linear arrangement of trees. The variety of trees ensures year round interest, biodiversity benefits and climate resilience.

Loading spaces integrated within the public realm.

A defined zone for vehicular access and cyclists.

Footpath providing access to adjacent buildings.



Materials that relate to local mews character and planting help define building edges and defensible space



# 6.4 West Brompton | Built Form

## Scales, uses and character

The variety of scales, uses and architectural character of West Brompton is informed by the existing context.

The Illustrative Masterplan responds to key built form principles outlined in the Control Documents, including:

- Creating a transition in scale between existing neighbouring terraced housing, mid-scale buildings and the taller buildings that frame the Table Park.
- Exploring the use of a variety of building typologies rooted in local and wider architectural character.
- Delivering a workspace cluster that frames Warwick Square, one of the three major commercial gateways in the masterplan.

West Brompton is comprised of the following built form typologies:

- Mid-scale
- Smaller-scale
- Pavilion
- ▶ Refer to Design Code / West Brompton / Built form (EC.PA.C).
- ▶ Refer to Design Code / Sitewide / Built form (EC.PA.C).
- ▶ Refer to Development Specification (EC.PA.A).

The below plans outline the land use emphasis of the Illustrative Masterplan within the Character Area. Full detail of the permitted land uses are described in the Development Specification.

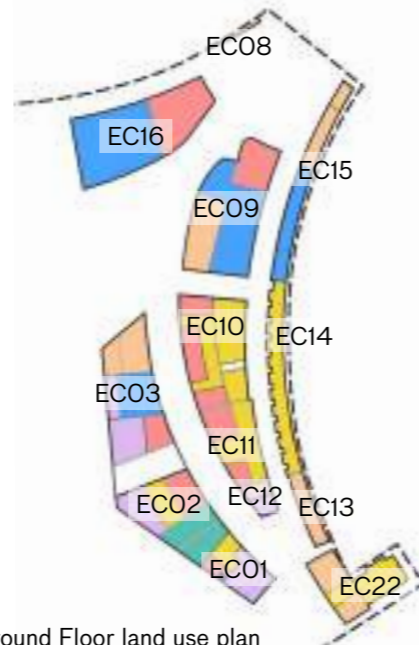

Illustrative Ground Floor land use plan

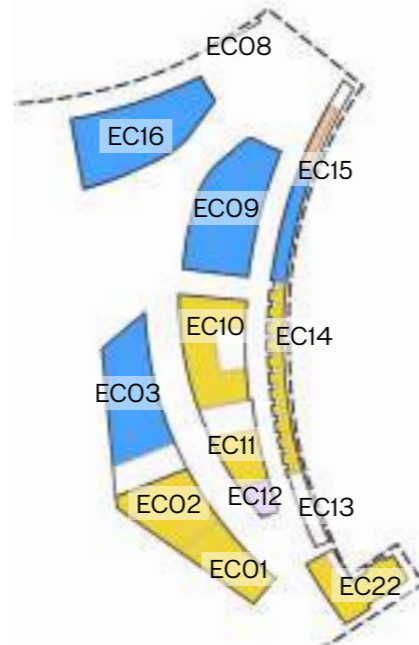

Illustrative typical Upper Floor land use plan

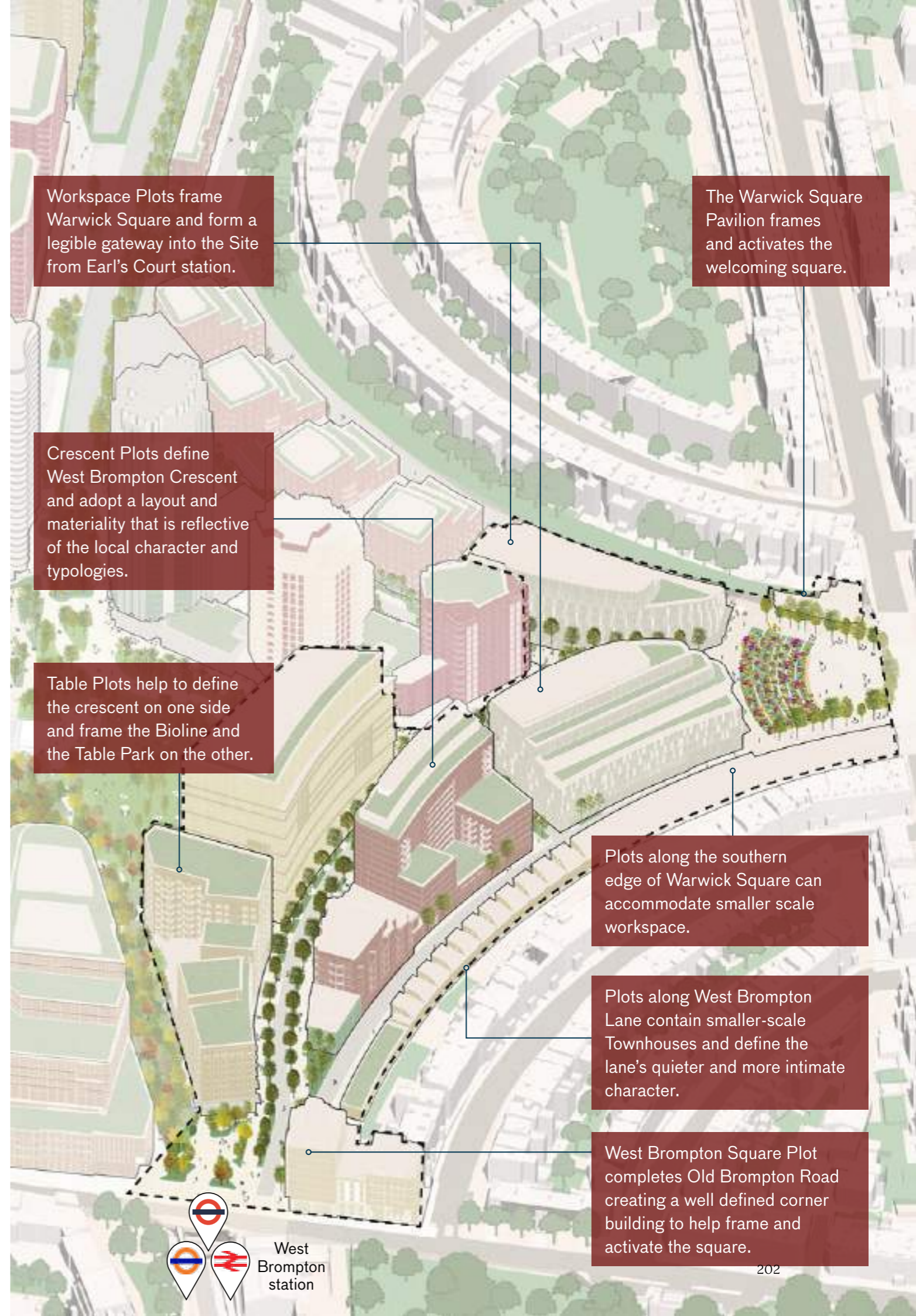



# 6.4 West Brompton | Built Form

Warwick Square Plots | West Brompton Square Plot | Table Plots | Crescent Plots | Lane Plots | Warwick Square Pavilion

## Warwick Square Plots

Plot Code: EC09, EC16  
 Typology: Mid-scale

Warwick Square is framed by a complementary pair of commercial buildings that frame the gateway, forming one of three innovation clusters across the Site.

The key principles that characterise Warwick Square Plots are described in the Design Code. These are demonstrated in the illustrative proposal, including:

- Creating a gateway with a complementary curvilinear pair of buildings.
- Enhancing the legibility and continuity of the crescents.
- Creating a mass that draws pedestrians to the heart of the Site while mediating a transition in building scale.
- Complementing the local context in materiality, composition, and grain.
- Articulating the top, middle and base of buildings.
- Creating an active Ground Floor, drawing people into the Site.

► Refer to Design Code / West Brompton / Built form / Mid-scale (EC.PA.C).

## Illustrative design response

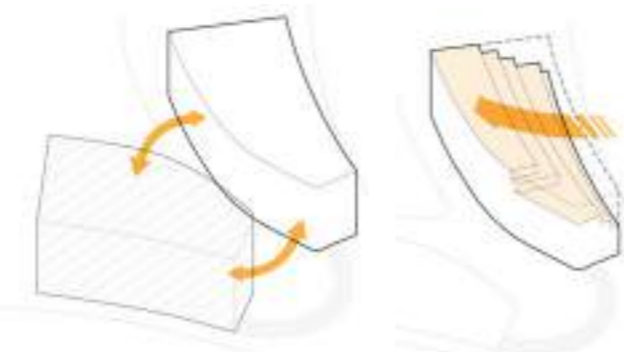

Complementary pair of buildings as gateway      Landscaped terraces as gateway

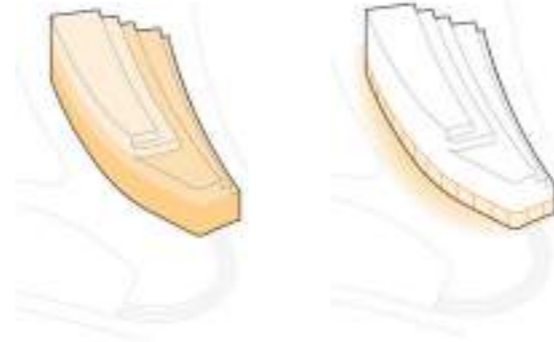

Articulating top, middle and base      Commercial with an active Ground Floor



Ground floor uses are broken into smaller units that could include cafés and exhibition spaces

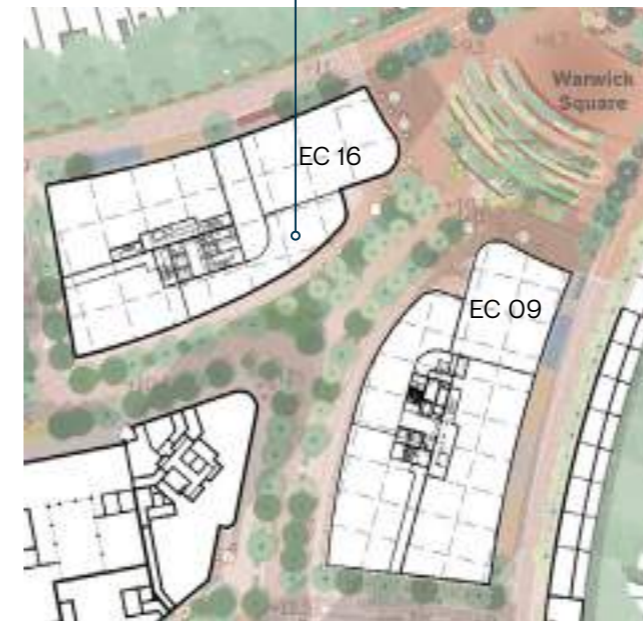

Illustrative mixed-use Ground Floor plan

Façades along the crescent and square are active and address the public space

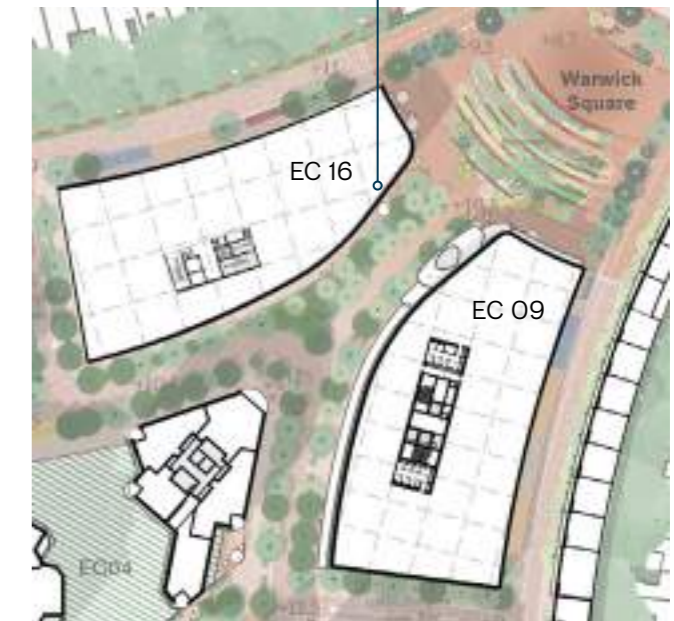

Illustrative workspace use typical Upper Floor plan



Eye-level view of Warwick Square showing the stepping down of the massing

# 6.4 West Brompton | Built Form

Warwick Square Plots | West Brompton Square Plot | Table Plots | Crescent Plots | Lane Plots | Warwick Square Pavilion

## Warwick Square Plots

The key principles that characterise Warwick Square Plots are described in the Design Code. These are demonstrated in the illustrative proposal, including:

**1** Active frontages to the square

The Ground Floor café and retail uses play a key role in activating the square and leading people into the crescent.

**2** Forming a gateway

The buildings on either side of the entrance to the crescent, ECO9 and EC16, respond to each other and the existing context providing a gateway into the Site.

**3** Facade articulation

Architectural components, hierarchy, detail and composition respond to the character of the local context.

► Refer to Design Code / West Brompton / Built form / Mid-scale (EC.PA.C).



Key plan

## Illustrative design response



Eye-level view from north of the edge of Warwick Square showing office space above active Ground Floors of retail and cafés



# 6.4 West Brompton | Built Form

Warwick Square Plots | West Brompton Square Plot | Table Plots | Crescent Plots | Lane Plots | Warwick Square Pavilion

## West Brompton Square Plot

Plot Code: EC22  
Typology: Mid-scale

The building on Old Brompton Road responds to the scale of the surrounding context whilst anchoring the corner with active frontage that addresses the station.

The key principles that characterise the West Brompton Square Plot are described in the Design Code. These are demonstrated in the illustrative proposal, including:

- Addressing Old Brompton Road and the square.
- Creating active frontage to the west facing the public realm.
- Stepping up in height, transitioning in scale from the Philbeach Conversation Area to the Site.
- Articulating corners with appropriate scale.
- The illustrative design has been informed by the consented scheme for this Plot.

► Refer to Design Code / West Brompton / Built form / Mid-scale (EC.PA.C).

## Illustrative design response

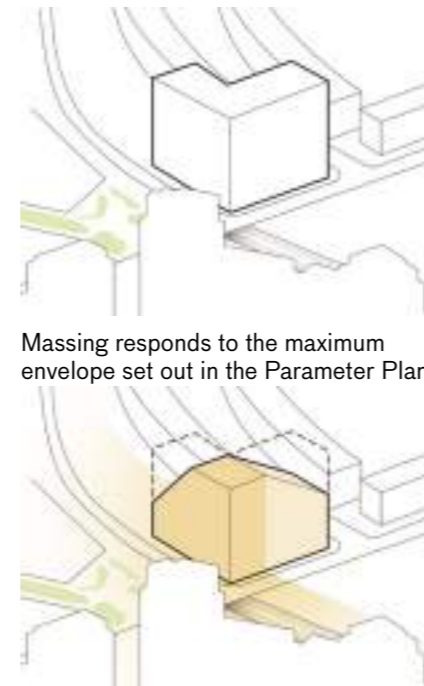
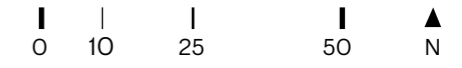

Massing responds to the maximum envelope set out in the Parameter Plans



Transition in scale from the Philbeach Conservation Area next to the Site

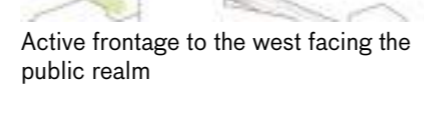

Active frontage to the west facing the public realm

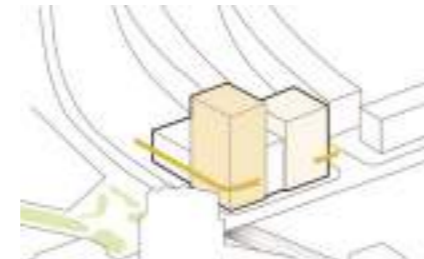

Articulation on the corners



Illustrative mixed-use Ground Floor plan



Illustrative residential use typical Upper Floor plan



Eye-level view along Old Brompton Road showing the building at the corner of the Site



# 6.4 West Brompton | Built Form

Warwick Square Plots | West Brompton Square Plot | Table Plots | Crescent Plots | Lane Plots | Warwick Square Pavilion

## Table Plots

Plot Code: EC01, EC02  
Typology: Mid-scale

The Table Plots front onto West Brompton Square, West Brompton Crescent and the Bioline. The Ground Floor is articulated to address the variety of uses and characters around the Plots.

The key principles that characterise the Table Plot are described in the Design Code. These are demonstrated in the illustrative proposal, including:

- Creating a continuous Ground Floor datum and consistent horizontal façade rhythm.
- Contributing to the legibility of the crescent through curvature of the façade.
- Animating the public realm with active frontages addressing West Brompton Square.

► Refer to Design Code / West Brompton / Built form / Mid-scale (EC.PA.C).

## Illustrative design response

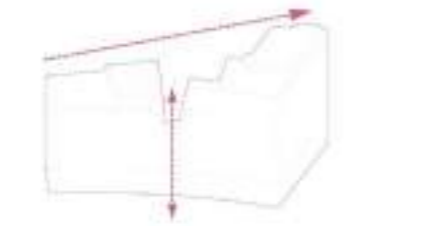

Massing responds to the maximum envelope set out in the Parameter Plans



Key façade activating the public square



Continuous building base addressing the crescent

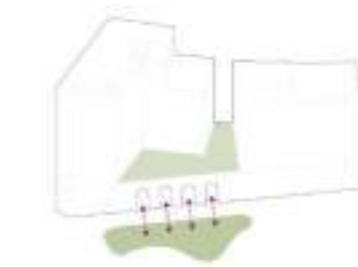

Addressing planting along the Bioline



Illustrative mixed-use Ground Floor plan



Illustrative residential use typical Upper Floor plan

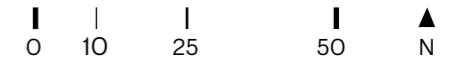

Eye-level view along the Bioline



# 6.4 West Brompton | Built Form

Warwick Square Plots | West Brompton Square Plot | Table Plots | Crescent Plots | Lane Plots | Warwick Square Pavilion

## Table Plots

Plot Code: EC03  
Typology: Mid-scale

The building form addresses both the West Brompton Crescent and the Table Park. It accentuates the crescent's curve and creates a special moment facing onto the Table Park.

The key principles that characterise the Table Plot are described in the Design Code. These are demonstrated in the illustrative proposal, including:

- Creating a prominent and considered façade addressing the Table Park.
- Reimagining the contextual mansion block typology along West Brompton Crescent.
- Creating a consistent rhythm and composition in-line with the character of West Brompton Crescent.
- Activating frontages on the ground level.
- The park facing elevation explores opportunities to integrate large scale terraces and planting, providing external space for the workspace uses.

► Refer to Design Code / West Brompton / Built form / Mid-scale (EC.PA.C).

## Illustrative design response

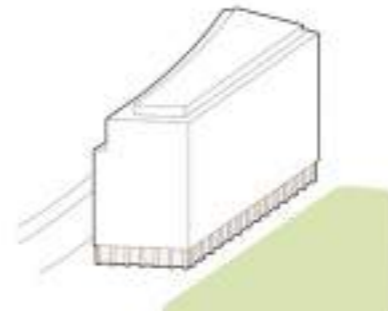

Active and open Ground Floor

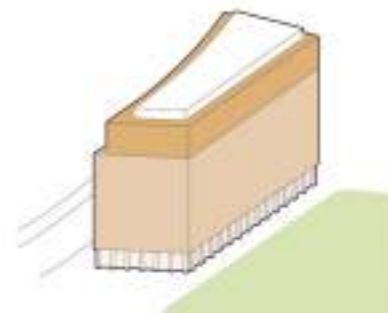

Base, middle, and top



Planted terraces



Multi-level windows



Illustrative mixed-use Ground Floor plan

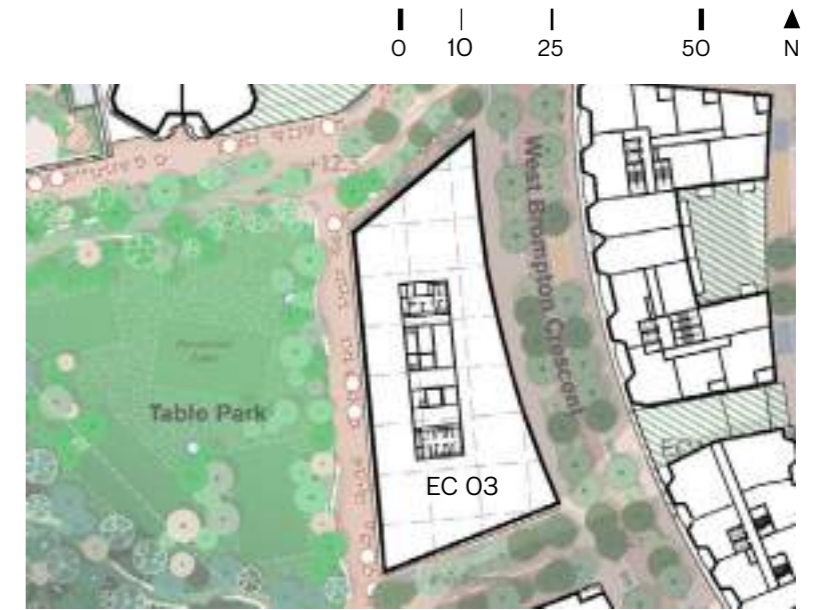

Illustrative workspace use typical Upper Floor plan



View at from the Table Park showing special features on the workspaces façades

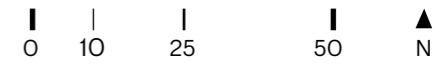

# 6.4 West Brompton | Built Form

Warwick Square Plots | West Brompton Square Plot | Table Plots | Crescent Plots | Lane Plots | Warwick Square Pavilion

## Crescent Plots

Plot Code: EC10, EC11, EC12  
Typology: Mid-scale

Buildings adopt a layout, composition and materiality that mediate between the edges of the site to the Plots on the edge of the Table Park.

The key principles that characterise the Crescent Plots are described in the Design Code. These are demonstrated in the illustrative proposal, including:

- Exploring the use of horizontal continuity, façade rhythms, and tone to establish a familiar character along the West Brompton Crescent.
- Creating a consistent shoulder height and order to the approach, contributing to the visible curve of West Brompton Crescent and Lane.
- Contrasting banding and expression of entrances provides richness in detail.
- Ground floor uses should be of a fine grain to respond to the local character.

► Refer to Design Code / West Brompton / Built form / Mid-scale (EC.PA.C).

## Illustrative design response



Building base to address West Brompton Crescent

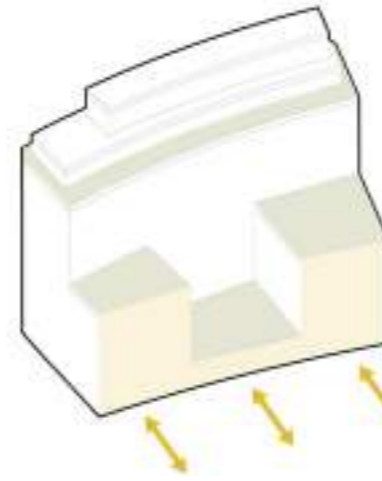

Façades responding to West Brompton Lane, stepping down in scale towards the existing terraced townhouses on Eardley Crescent



Balcony amenity spaces face onto West Brompton Crescent and create articulation on the crescent elevations



Illustrative mix use Ground Floor plan



Illustrative residential use typical Upper Floor plan



Eye-level view of EC12 from West Brompton Place

# 6.4 West Brompton | Built Form

Warwick Square Plots | West Brompton Square Plot | Table Plots | Crescent Plots | Lane Plots | Warwick Square Pavilion

## Crescent Plots

The key principles that characterise the Crescent Plots are described in the Design Code. These are demonstrated in the illustrative proposal, including:

- 1** Creating a coherent architectural expression  
Buildings establish a coherent relationship and character through common horizontal datums, façade rhythms, tone and materials.
- 2** Exploring and interpreting an urban grain  
Building expression is consistent along the façade of the upper levels and reflects interpretations of local mansion block typologies.
- 3** Establishing a variety of unit sizes for Ground Floor uses  
The Ground Floor café, restaurant and retail uses are accommodated in a variety of unit sizes, aligning to the local character.

► Refer to Design Code / West Brompton / Built form / Mid-scale (EC.PA.C).



Key plan

## Illustrative design response

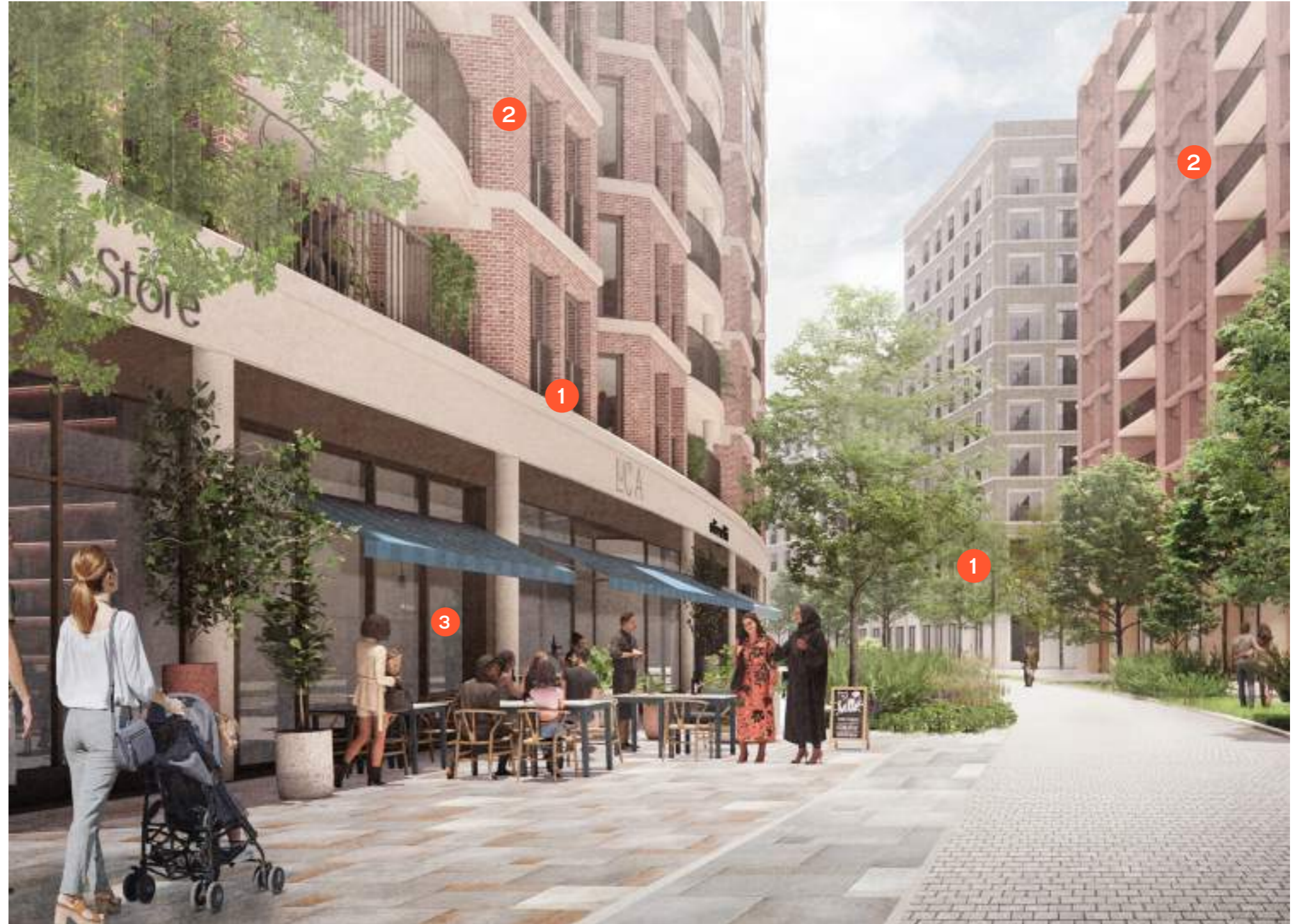

Eye-level view of West Brompton Crescent showing homes above an activated retail crescent



# 6.4 West Brompton | Built Form

Warwick Square Plots | West Brompton Square Plot | Table Plots | Crescent Plots | Lane Plots | Warwick Square Pavilion

## Lane Plots

Plot Code: EC13, EC14, EC15  
Typology: Smaller-scale buildings

Townhouses and low-rise workspace units create a smaller-scale along West Brompton Lane, next to Eardley Crescent.

The key principles that characterise the Lane Plots are described in the Design Code. These are demonstrated in the illustrative proposal, including:

- Developing a façade rhythm and material palette that responds to existing neighbouring buildings.
- Providing individual doors and entrances, enhancing West Brompton Lane’s distinct character and façade rhythm.
- Creating stepped roofs and a varied streetscape, reinforcing the lane’s intimate scale and character.

► Refer to Design Code / West Brompton / Built form / Smaller-scale (EC.PA.C).

## Illustrative design response

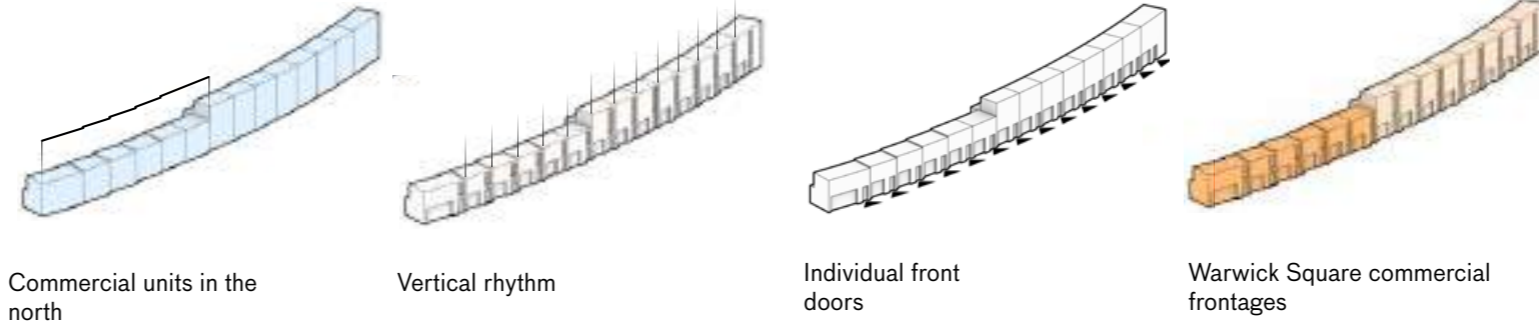

Eye-level view looking along West Brompton Lane at the workspace units



Illustrative typical plan





## 6.4 West Brompton | Built Form

Warwick Square Plots | West Brompton Square Plot | Table Plots | Crescent Plots | Lane Plots | Warwick Square Pavilion

### Lane Plots

The key principles that characterise the Lane Plots are described in the Design Code. These are demonstrated in the illustrative proposal, including:

- 1** Creating continuity along the lane  
Building façades form a consistent frontage and composition.
  - 2** Articulating the building line  
Offsets from the maximum building line create entrances and defensible space.
  - 3** Creating a segregated footpath  
Segregated footpaths minimise conflict between pedestrian and vehicle movement.
- Refer to Design Code / West Brompton / Built form / Smaller-scale (EC.PA.C).



Key plan

### Illustrative design response



Eye-level view showing West Brompton Lane and the residential townhouses



# 6.4 West Brompton | Built Form

Warwick Square Plots | West Brompton Square Plot | Table Plots | Crescent Plots | Lane Plots | Warwick Square Pavilion

## Pavilion

Plot Code: EC08  
Typology: Pavilion

The Pavilion frames and activates the northern edge of Warwick Square.

The key principles that characterise the Pavilion are described in the Design Code. These are demonstrated in the illustrative proposal, including:

- Creating a unique and memorable structure that adds to the identity of the Warwick Square.
- Providing a flexible space to accommodate cultural uses, small retail units, or a coffee shop.
- Addressing the existing blank party wall, framing the square.
- Negotiating below ground constraints.

► Refer to Design Code / West Brompton / Built form / Pavilion (EC.PA.C).

## Illustrative design response

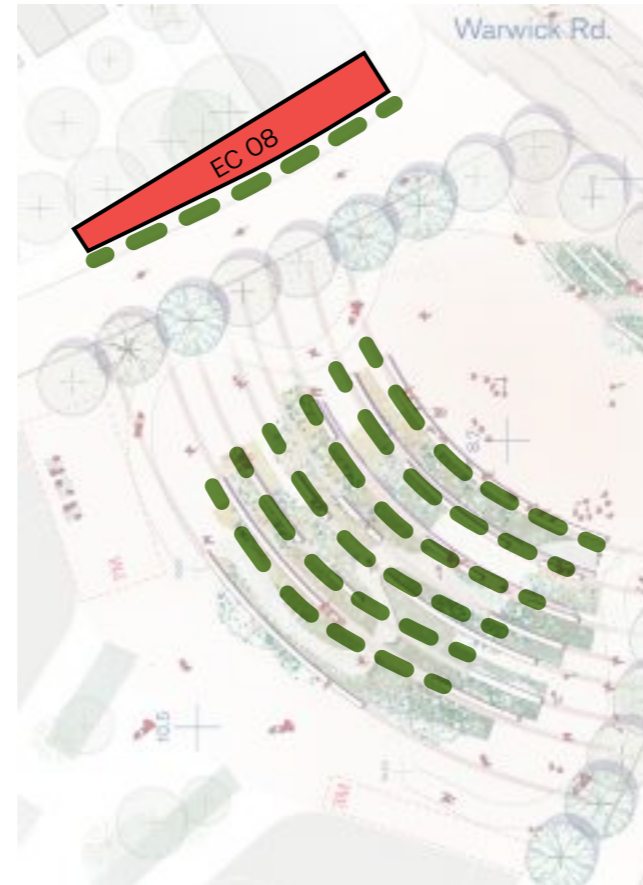

Pavilion relates to the design of the Warwick Square Flower Amphitheatre



Pavilion can be a flexible space accommodating cultural uses



Eye-level view showing how the Pavilion integrates planting within the façade design

# Warwick Crescent





# 6.5 Warwick Crescent | Overview

Warwick Crescent is a quiet and contemporary residential area centred around a landscaped crescent that draws on local character and prioritises pedestrians.

This section illustrates how the Character Area has been developed alongside the Control Documents. Key principles that characterise Warwick Crescent are set out on the image on the right.

► Refer to Design Code / Warwick Crescent (EC.PA.C).

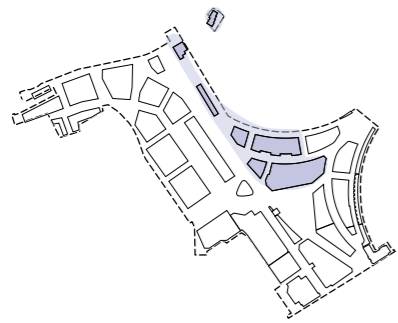

Location of West Brompton Character Area

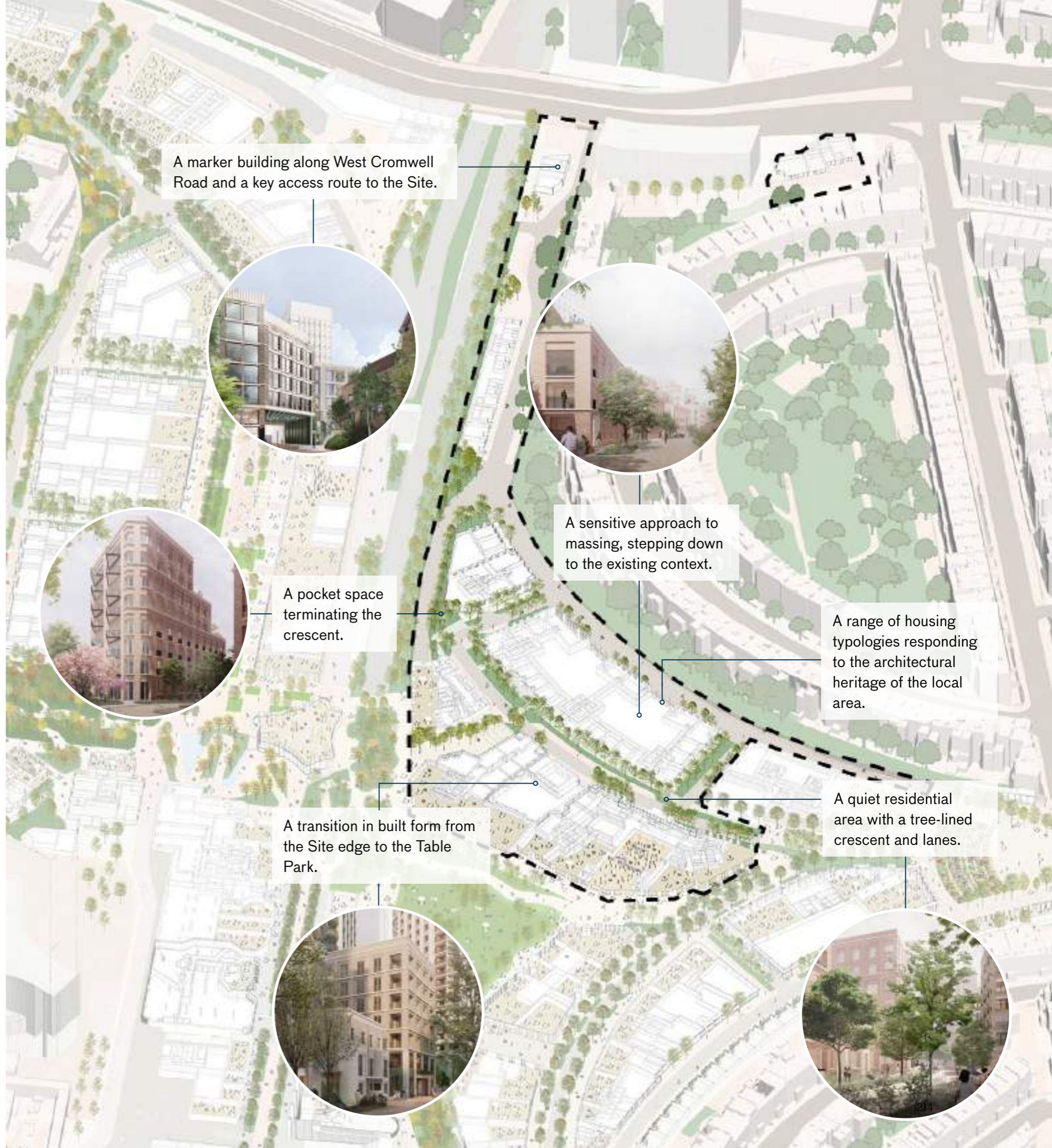

A marker building along West Cromwell Road and a key access route to the Site.



A sensitive approach to massing, stepping down to the existing context.



A pocket space terminating the crescent.

A range of housing typologies responding to the architectural heritage of the local area.

A transition in built form from the Site edge to the Table Park.

A quiet residential area with a tree-lined crescent and lanes.





# 6.5 Warwick Crescent | Public Realm

Warwick Crescent consists of a hierarchy of spaces and routes, creating a network of pedestrian-priority green streets. The public realm responds to the local character, offering quiet and intimate outdoor spaces for residents to enjoy.

Key spaces and routes are outlined in the Control Documents including:

### Spaces and routes

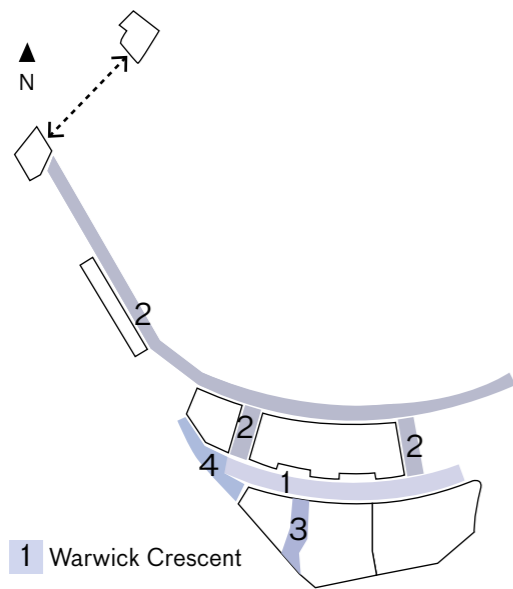

- 1 Warwick Crescent
- 2 Warwick Lane, St Cuthbert's Lane, Warwick Lane East, Warwick Lane West
- 3 Warwick Walk (detailed application)
- 4 Warwick Place

Refer to Design Code / Warwick Crescent / Landscape (EC.PA.C).

Refer to Design Code / Sitewide / Landscape (EC.PA.C).

### Access and movement

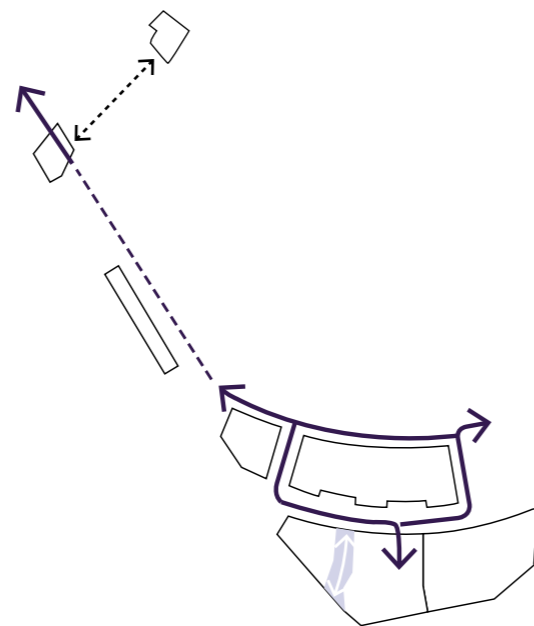

- Vehicle free public realm (cyclist on demarcated route)
- Vehicle access
- Indicative route to Cluny Mews (to be delivered outside the Site boundary and subject to third party land agreements)

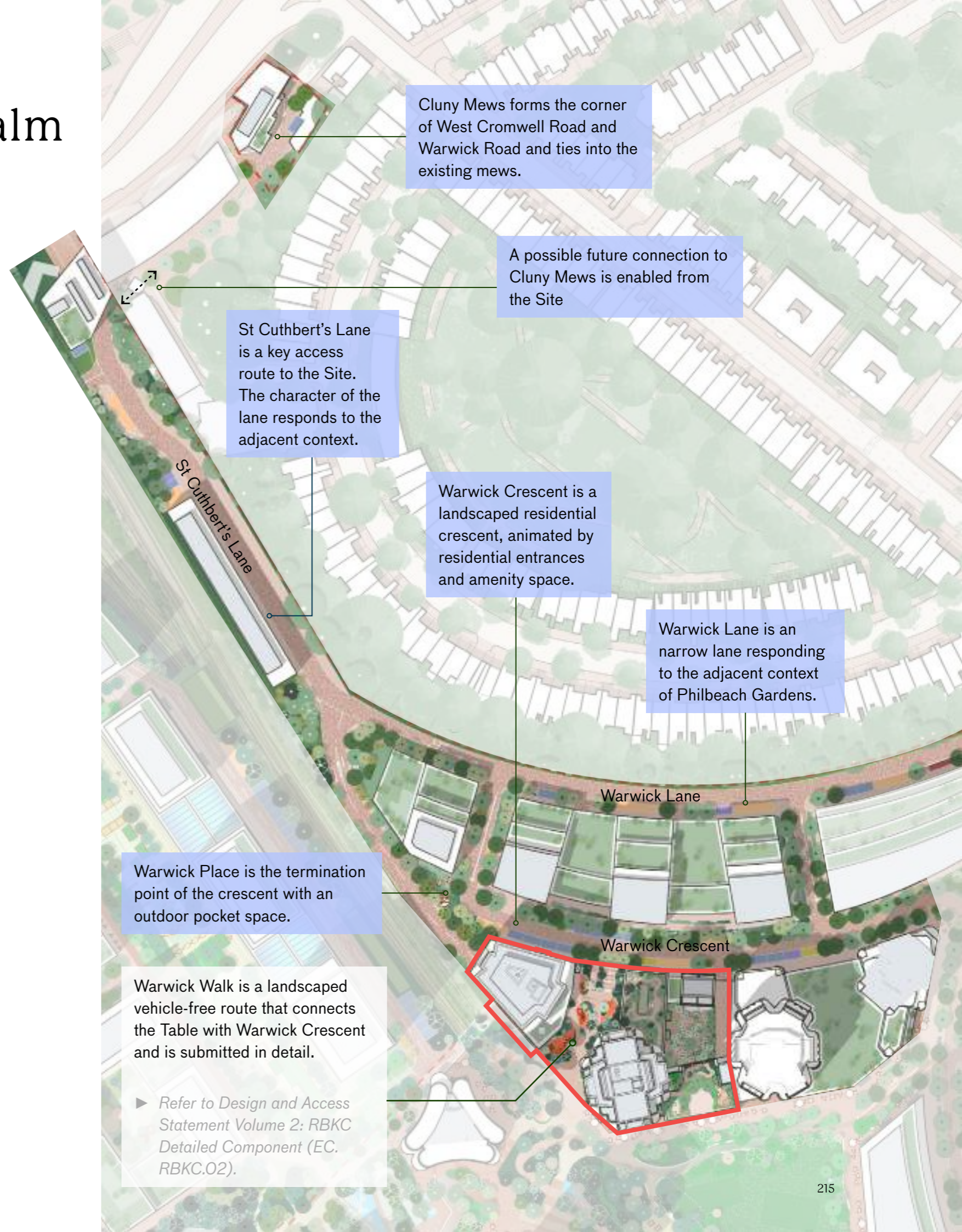

Cluny Mews forms the corner of West Cromwell Road and Warwick Road and ties into the existing mews.

A possible future connection to Cluny Mews is enabled from the Site

St Cuthbert's Lane is a key access route to the Site. The character of the lane responds to the adjacent context.

Warwick Crescent is a landscaped residential crescent, animated by residential entrances and amenity space.

Warwick Lane is a narrow lane responding to the adjacent context of Philbeach Gardens.

Warwick Place is the termination point of the crescent with an outdoor pocket space.

Warwick Walk is a landscaped vehicle-free route that connects the Table with Warwick Crescent and is submitted in detail.

Refer to Design and Access Statement Volume 2: RBKC Detailed Component (EC.RBKC.02).



# 6.5 Warwick Crescent | Public Realm

Crescent | Lanes

## Warwick Crescent

Warwick Crescent is a contemporary residential crescent with the character of a tree-lined street, intensely landscaped for sustainable drainage and for residents to enjoy.

Residential entrances to buildings and to individual homes are located either side of the crescent.

The key principles that characterise Warwick Crescent are described in the Design Code. These are demonstrated in the illustrative proposal, including:

- Creating a tree-lined street referencing local street typologies.
- Creating defensible space in front of entrances and habitable rooms.
- Activated with residential front entrances and amenity spaces.

▶ Refer to Design Code / Warwick Crescent / Landscape / Warwick Crescent (EC.PA.C).

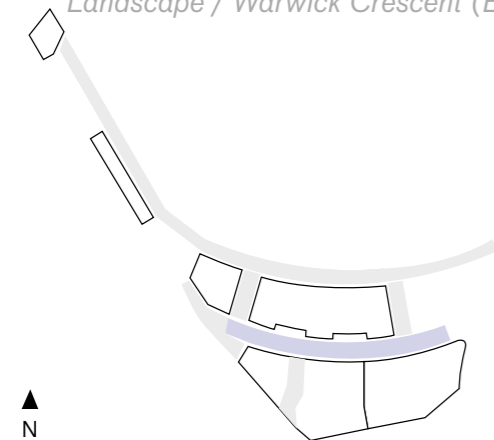

## Illustrative design response

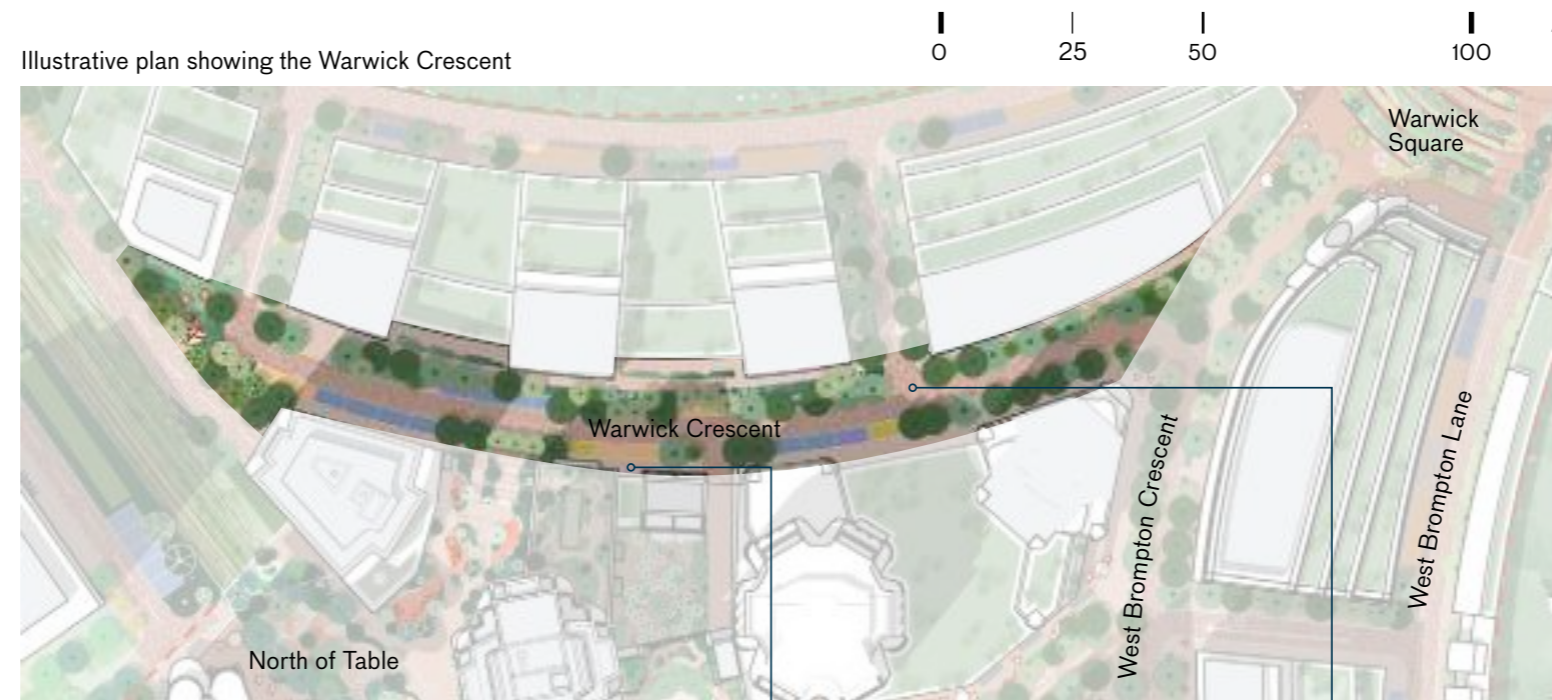

Defensible space is located adjacent to habitable rooms at ground level

Landscape design helps to make building entrances legible

Trees line both sides of the street, referencing local street typologies



Warwick Crescent street section



Pedestrian-priority street where people move comfortably and have priority over cars



Defensible space adjacent to habitable rooms located at ground level



Pedestrian streets landscaped with furniture and spaces for dwelling



## 6.5 Warwick Crescent | Public Realm

Crescent | Lanes

### Warwick Crescent

The key principles that characterise Warwick Crescent are described in the Design Code. These are demonstrated in the illustrative proposal, including:

**1** Creating a tree-lined street typology

A tree-lined street is created, responding to local street typologies. Zones for pedestrian movement and planting are prioritised, limiting the central carriage way width to one-way vehicular access.

**2** Activating the Crescent

Residential front doors, entrance lobbies and amenity space activate the crescent and give it a neighbourhood character.

**3** Creating defensible space

Defensible space provides privacy for Ground Floor residents as well as visual amenity.

► Refer to Design Code / Warwick Crescent / Landscape / Warwick Crescent (EC.PA.C).



Key plan

### Illustrative design response



Eye-level view of Warwick Crescent showing a residential crescent, quiet and leafy in character



# 6.5 Warwick Crescent | Public Realm

Crescent | Lanes

## Warwick Lane

Warwick Lane is a narrower lane that runs along the Site's edge between new homes and neighbouring Philbeach Gardens properties.

The key principles that characterise Warwick Lane are described in the Design Code. These are demonstrated in the illustrative proposal, including:

- Creating a planted character that helps transition to the back gardens of the existing houses.
- Providing residential and servicing access to homes.
- Creating active frontages through residential entrances, amenities and other ancillary uses.

▶ Refer to Design Code / Warwick Crescent / Landscape / Warwick Lane (EC.PA.C).

▶ Refer to Design and Access Statement Volume 1: Outline Component / Site Context and Analysis / The Site / The crescents (EC.PA.08).

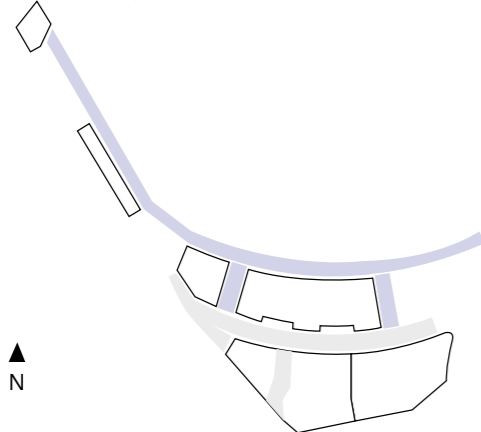

## Illustrative design response

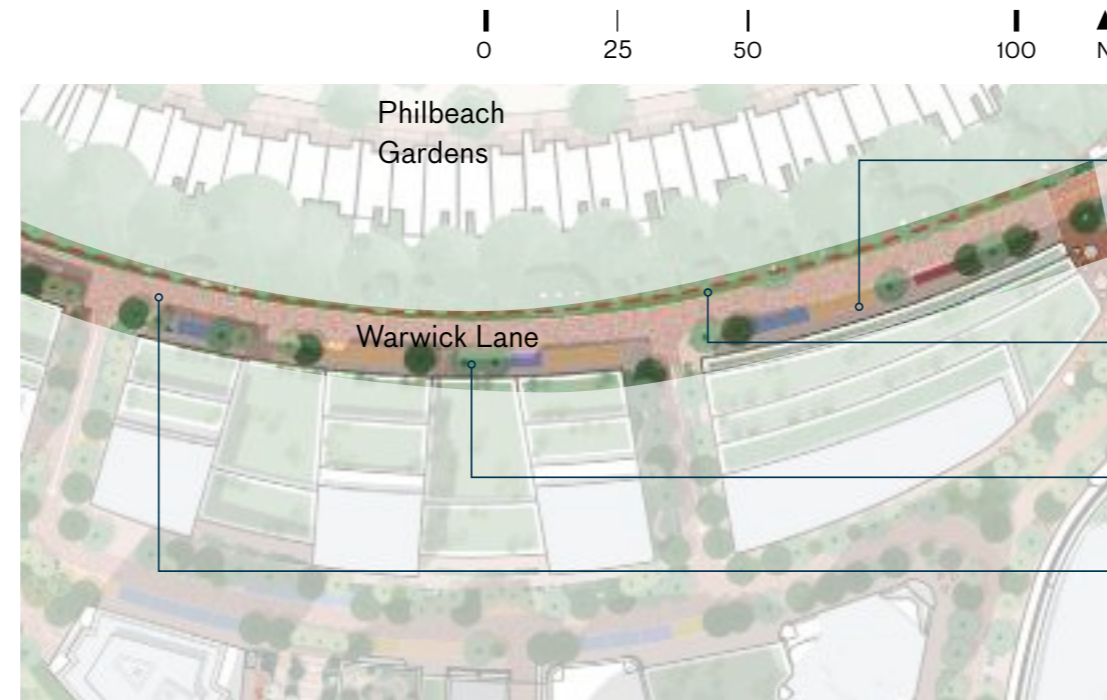

Illustrative plan showing Warwick Lane



Warwick Lane street section

Vehicle and blue badge parking is integrated in the lane and landscape

Supplementary planting along existing boundaries softens the Site's edge condition

Planted zones between blue badge parking spaces and loading bays

A quiet two-way residential street with lower levels of traffic and pedestrian priority

Existing boundary wall

Planting along the Site boundary

Defensible space in front of homes

Planted zones separate vehicular movements from pedestrians and offer a buffer to the homes at ground level



Planting areas provide street greening



Planting zones create a green edge next to the street



A street with pedestrian priority





## 6.5 Warwick Crescent | Public Realm

Crescent | Lanes

### Warwick Lane

The key principles that characterise Warwick Lane are described in the Design Code. These are demonstrated in the illustrative proposal, including:

**1** Creating a well defined boundary treatment

Planting along the existing Site boundary wall responding to the adjacent gardens.

**2** Allowing for a pedestrian footpath

Footpath located to the south of the lane for access to residential properties.

**3** Creating a sensitive material treatment

Surface material encourages low speeds and reinforces the lane's character.

**4** Activating Warwick Lane

Homes with front doors activating the lane.

► Refer to Design Code / Warwick Crescent / Landscape / Warwick Lane (EC.PA.C).



Key plan

### Illustrative design response



Eye-level view showing the character of Warwick Lane along the Site edge

# 6.5 Warwick Crescent | Public Realm

Crescent | Lanes

## St. Cuthbert's Lane

St Cuthbert's Lane is an extension of Warwick Lane. It draws people into the Earls Court through a route underneath West Cromwell Road, connecting to Warwick Square and beyond.

The key principles that characterise St Cuthbert's Lane are described in the Design Code. These are demonstrated in the illustrative proposal, including:

- Responding to the local context, and the setting of the Grade I listed St Cuthbert's Church, especially through use of planting and materials.
- Minimising the impact of overlooking with a designated tree line, planting and boundary brick wall adjacent to Philbeach Gardens.
- Enabling a future connection to Cluny Mews.\*

\* The connection to Cluny Mews is located outside of the Site Boundary and relies on third party agreements.

▶ Refer to Design Code / Warwick Crescent / Landscape / St Cuthbert's Lane (EC.PA.C).

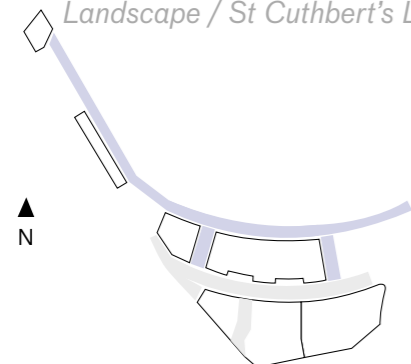

## Illustrative design response



Planting along the railway, softening the edges of the Site



Interface with St Cuthbert's Church



Landscaped brick boundary



Illustrative public realm plan showing St. Cuthbert's Lane



Eye-level view showing St. Cuthbert's Lane and a potential connection to Cluny Mews



Eye-level view showing planting along St. Cuthbert's Lane



## 6.5 Warwick Crescent | Public Realm

Crescent | Lanes

### St. Cuthbert's Lane

The key principles that characterise St Cuthbert's Lane are described in the Design Code. These are demonstrated in the illustrative proposal, including:

**1** Creating a sensitive boundary treatment

Planting along the existing Site boundary wall buffering the adjacent gardens.

**2** Extending the character of Warwick lane

Materiality and landscape treatment extends the character of Warwick Lane.

**3** Planning for nature-based landscaped areas

Additional planting and landscaped areas further amplify nature.

► Refer to Design Code / Warwick Crescent / Landscape / St Cuthbert's Lane (EC.PA.C).



Key plan

### Illustrative design response



Eye-level view showing the transition from Warwick Lane to St Cuthbert's Lane

# 6.5 Warwick Crescent | Built Form

The buildings along Warwick Crescent gradually decrease in height towards the edges to transition sensitively into the neighbouring crescents.

The Illustrative Masterplan responds to key built form principles outlined in the Control Documents, including:

- Creating a rich architectural and landscape character that emerges from the place.
- Stepping down in scale to respond to the existing context.
- Organising ‘families of buildings’ and creating permeability in the massing.
- Locating higher buildings to assist with orientation and wayfinding.

Warwick Crescent is comprised of the following built form typologies:

- Mid-scale
  - Smaller-scale
  - Common base
  - Standalone
  - Detailed Components (refer to Detailed Component DAS)
- ▶ Refer to Design Code / Warwick Crescent / Built form (EC.PA.C).
- ▶ Refer to Design Code / Sitewide / Built form (EC.PA.C).
- ▶ Refer to Development Specification (EC.PA.A).

The below plans outline the land use emphasis of the Illustrative Masterplan within the Character Area. Full detail of the permitted land uses are described in the Development Specification.

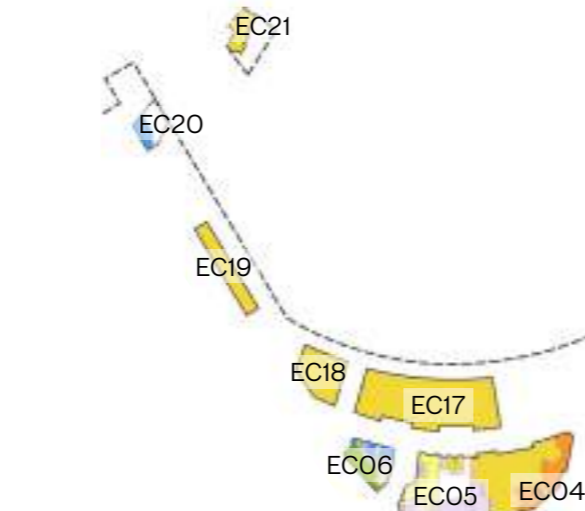

Illustrative Ground Floor land use plan

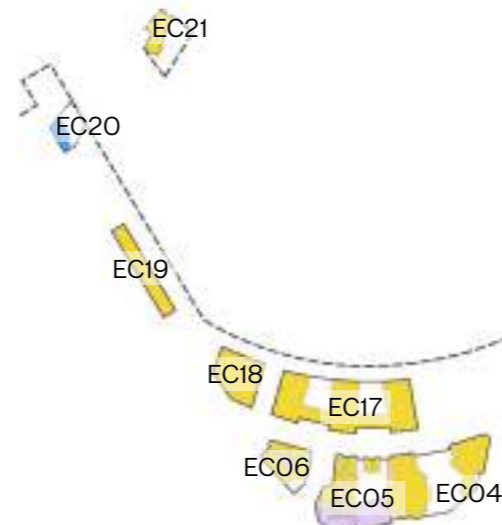

Illustrative typical Upper Floor land use plan

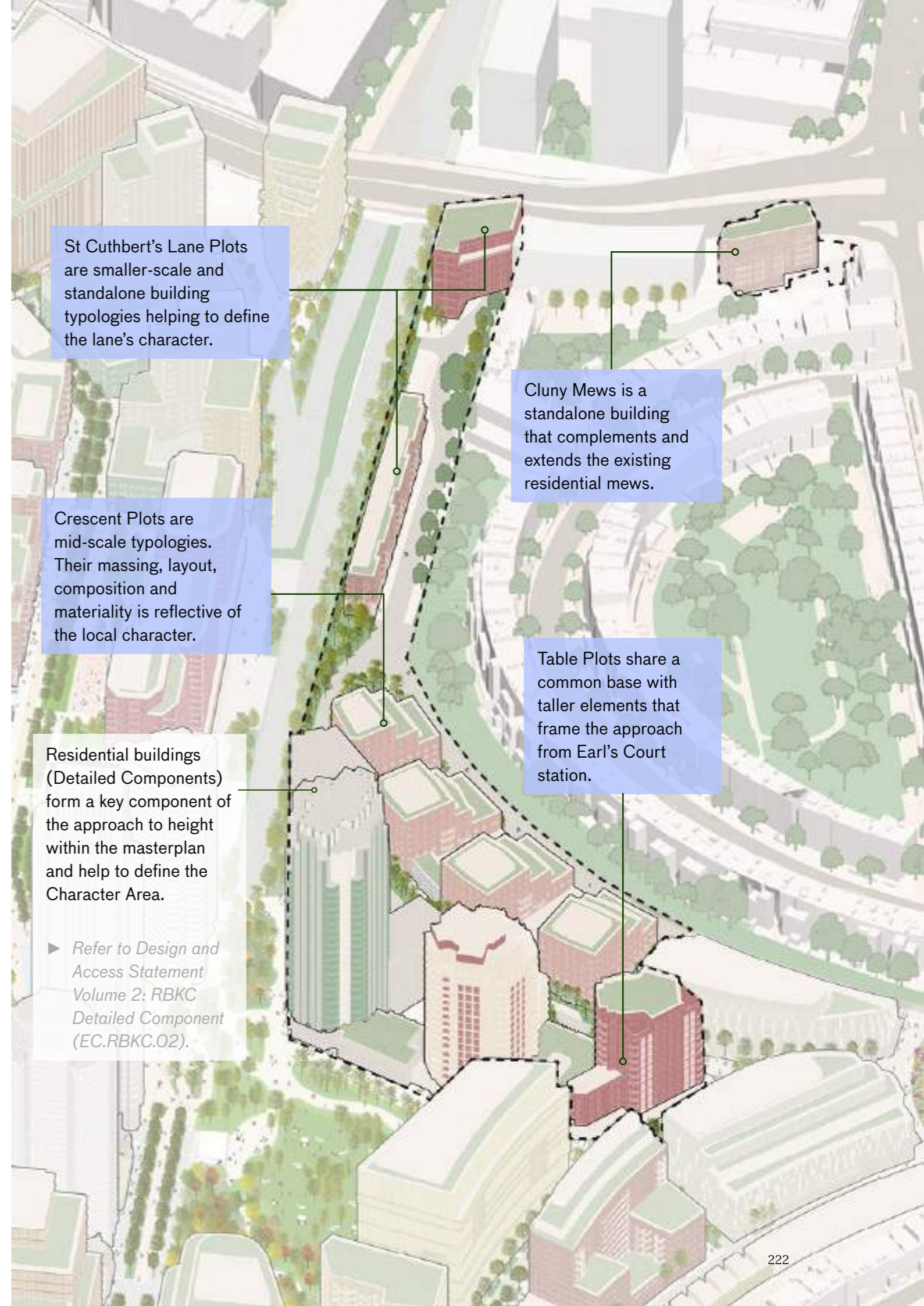

# 6.5 Warwick Crescent | Built Form

Crescent Plots | Table Plots | Lane Plots | Cluny Mews

## Crescent Plots

Plot Code: EC17, EC18  
Typology: Mid-scale

Mid-rise mansion blocks frame the northern edge of Warwick Crescent, featuring stepped buildings along with residential layouts, composition, and materials that respond to the local character and scale.

The key principles that characterise the Crescent Plots are described in the Design Code. These are demonstrated in the illustrative proposal, including:

- Developing an interpretation of a prevailing typology in the area, the mansion block.
- Creating a consistent shoulder height that helps to define the form of the crescent.
- Using setbacks to allow light penetration through breaks between building forms.
- Stepping buildings to form a layered composition that features a distinctive base, middle, and top.

► Refer to Design Code / Warwick Crescent / Built form / Mid-scale (EC.PA.C).

## Illustrative design response

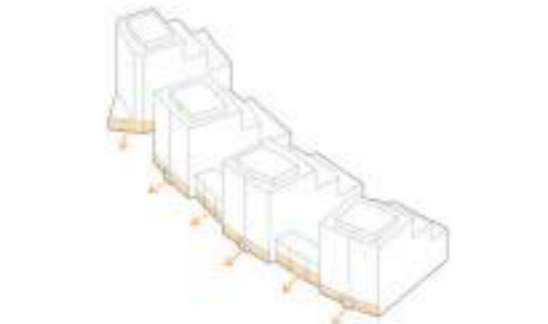

Ground floor entrances animate crescent

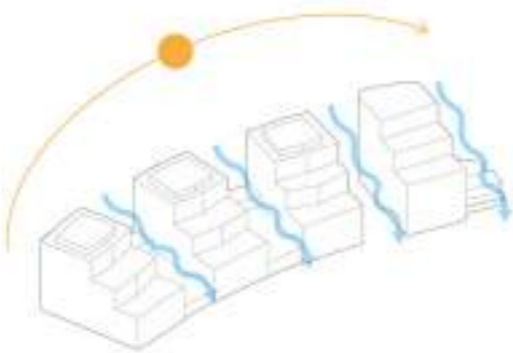

Breaks for sunlight to penetrate between buildings

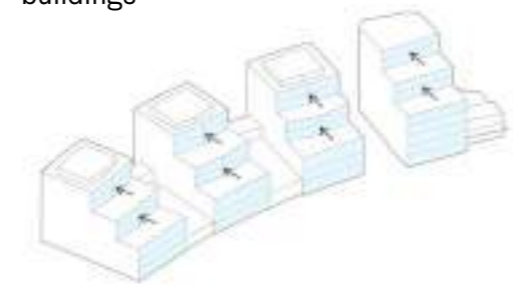

Buildings step down towards the edge



Façade articulation



Illustrative Ground Floor plan - predominantly residential use

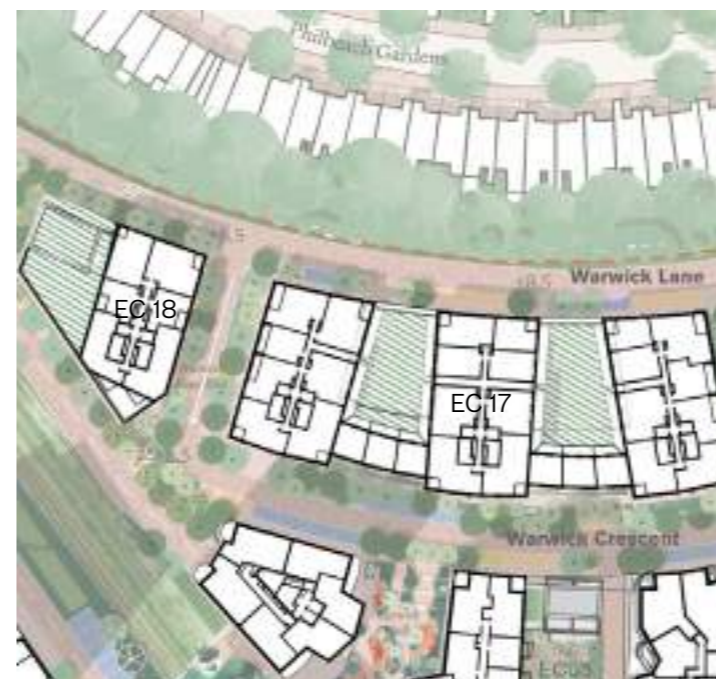

Illustrative typical Upper Floor plan - residential use



Eye-level view showing the mansion block typology

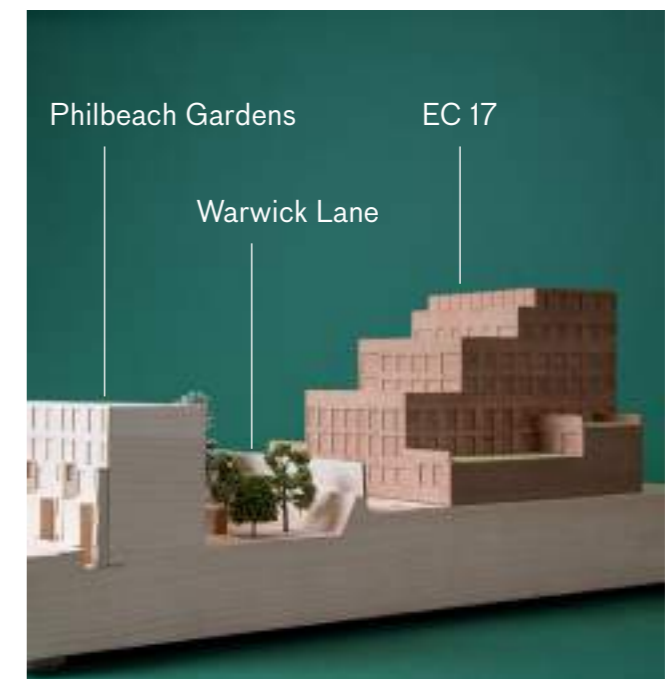

Illustrative model showing the sensitive stepped approach to scale along Warwick Lane

# 6.5 Warwick Crescent | Built Form

Crescent Plots | Table Plots | Lane Plots | Cluny Mews

## Table Plots

Plot Code: EC04  
Typology: Common base

This family of buildings coherently responds to the adjacent plots being developed in detail. They frame the Table Park and share a common base that activates the public realm.

The key principles that characterise the Table Plots are described in the Design Code. These are demonstrated in the illustrative proposal, including:

- Aligning with the strategic approach to a stepped built form by creating heights that descend from the Table Park frontage towards the crescent.
  - Creating a cohesive character along the edge of the Table Park and crescent.
  - Creating a permeable and open design that allows sunlight to penetrate through the massing.
  - Designing a common building base alive with cafés, bars, and cultural spaces that activate the edge of the Table Park and the crescent.
- ▶ Refer to Design Code / Warwick Crescent / Built form / Common Base (EC.PA.C).
- ▶ Refer to Design and Access Statement Volume 2: RBKC Detailed Component (EC.RBKC.02).

## Illustrative design response



Ground floor entrances animate crescent



Breaks for sunlight to penetrate between the buildings



Entrances and active frontages animate the Table Park



A family of buildings create a cohesive character along the edge of the Table Park and crescent



Illustrative Ground Floor plan - mixed-use



Illustrative typical Upper Floor plan - residential use



Eye-level view showing later living along Warwick Crescent



Illustrative sketch showing how illustrative and detailed (outlined in red) Plots form a cohesive response



# 6.5 Warwick Crescent | Built Form

Crescent Plots | Table Plots | Lane Plots | Cluny Mews

## Cultural activation

Plot Code: ECO4  
Typology: Common base

A flexible cultural venue at the base of the Table Plot creates one of the key anchor destinations within the masterplan and frame the Table Park at the centre of the Site.

The design of this cultural space features a prominent entrance and signage to activate the corner. Located at the confluence of Warwick and West Brompton Crescent, this space draws people from Warwick Square to the Table Park. Associated food and beverage uses complement the cultural space and activate the edge of the Table Park, creating a vibrant new neighbourhood.



Key plan

## Illustrative design response



Illustrative eye-level sketch showing the prow of ECO4 and prominent cultural entrance



Illustrative section of spatial relationship between the Table Park and the potential cultural venue



Illustrative view of the cultural venue use as a fashion event



## 6.5 Warwick Crescent | Built Form

Crescent Plots | Table Plots | Lane Plots | Cluny Mews

### Table Plots

The key principles that characterise the Table Plots are described in the Design Code. These are demonstrated in the illustrative proposal, including:

**1** Developing a coherent architectural response

The Table Plots share common horizontal expressions. Complementary façade rhythms and tone help create a coherent streetscape.

**2** Referencing Detailed Component design

Massing, articulation and architectural expression are designed to create a coherence with the proposals submitted in detail.

**3** Creating a relationship between the buildings as they come to ground

Residential entrances, including front doors to individual homes, are located at ground level reinforcing the residential nature of the Character Area.

► Refer to Design and Access Statement Volume 2: RBKC Detailed Component (EC.RBKC.02).



Key plan

### Illustrative design response



Eye-level view showing the façade of the Table Plots forming the crescent



# 6.5 Warwick Crescent | Built Form

Crescent Plots | Table Plots | Lane Plots | Cluny Mews

## Lane Plot

Plot Code: EC19  
Typology: Smaller-scale

Along St. Cuthbert's Lane, a low-rise residential building with street-facing front doors reflects the quiet character and modest scale of the existing local context.

The key principles that characterise the Lane Plots are described in the Design Code. These are demonstrated in the illustrative proposal, including:

- Developing an integrated typology that addresses St Cuthbert's Lane, and the railway.
- Creating an active frontage on the lane with regular residential entrances at ground.
- Mitigating noise and improving air quality by creating a buffer to the railway.
- Generating façades that have a rhythm and grain that responds to the local context.

► Refer to Design Code / Warwick Crescent / Built form / Smaller-scale (EC.PA.C).

## Illustrative design response

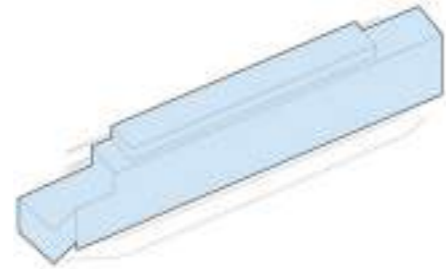

Maximum envelope defined by the Parameter Plans



Primary frontage onto St. Cuthbert's Lane and activation of Ground Floor



Air quality strategies for the side facing the tracks consider noise mitigation



Rhythm and grain - gallery access is located on one elevation and balconies articulate the other

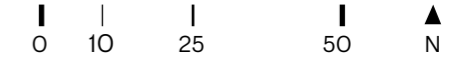

Illustrative Ground Floor plan showing residential use



Illustrative typical Upper Floor plan showing residential use



Eye-level view showing smaller scale residential building on St. Cuthbert's Lane



# 6.5 Warwick Crescent | Built Form

Crescent Plots | Table Plots | Lane Plots | Cluny Mews

## Lane Plot

Plot Code: EC20  
Typology: Standalone

A standalone building marks the end of St Cuthbert's Lane. The building bridges over the road and a clear geometry helps with wayfinding and navigation.

The key principles that characterise the Lane Plot are described in the Design Code. These are demonstrated in the illustrative proposal, including:

- Creating a presence along West Cromwell Road as a marker at the edge of the Site.
- Assisting with wayfinding to frame the entrance into the 100 West Cromwell Road basement to the north of the Site, providing the only vehicular access from that edge.
- Locating workspace units above that overlook the public realm, making it safe and helping with wayfinding and orientation.
- Choosing materials that respond to the local context, including the setting of St Cuthbert's Church.

► Refer to Design Code / Warwick Crescent / Built form / Standalone (EC.PA.C).

## Illustrative design response

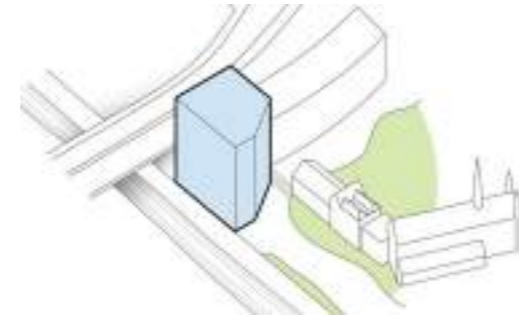

Maximum envelope defined by the Parameter Plans

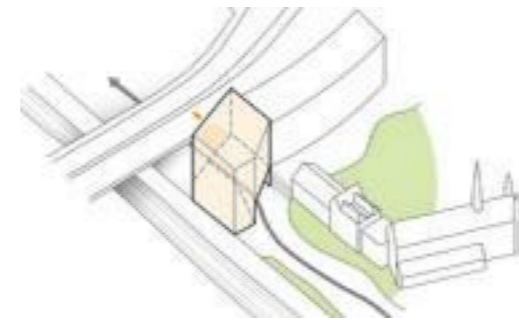

Access through to the Tesco basement

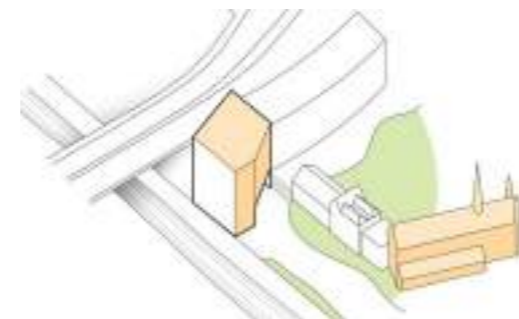

Façade materiality responds to St Cuthbert's Church

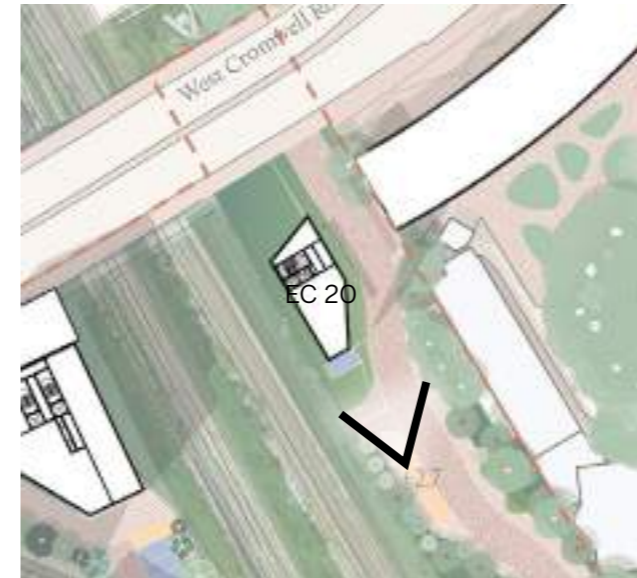
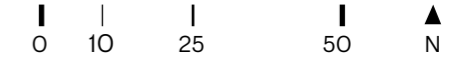

Illustrative Ground Floor plan - workspace use

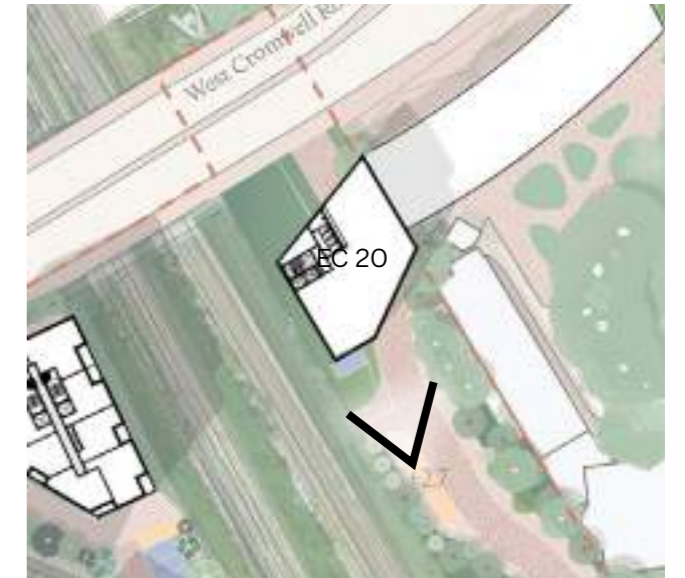

Illustrative typical Upper Floor plan - workspace use



Eye-level view of St Cuthbert's Lane workspace building



# 6.5 Warwick Crescent | Built Form

Crescent Plots | Table Plots | Lane Plots | Cluny Mews

## Cluny Mews

Plot Code: EC21  
Typology: Standalone

Cluny Mews is a low-scale standalone residential building that respects the quiet character of the existing mews street whilst creating a distinctive presence to West Cromwell Road to the north.

The key principles that characterise the Cluny Mews Plot are described in the Design Code. These are demonstrated in the illustrative proposal, including:

- Adopting a residential scale, with the building entrances located to prioritise privacy and minimise impact to neighbours.
- Creating a southern façade designed to respect nearby residences with building elements that align with the size and scale of surrounding buildings.
- Designing a distinctive elevation facing West Cromwell Road.

► Refer to Design Code / Warwick Crescent / Built form / Standalone(R) (EC.PA.C).

## Illustrative design response

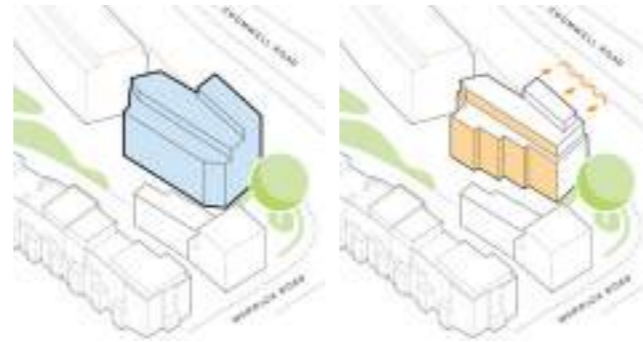

Maximum envelope defined by the Parameter Plans

Stepped façade to minimise overlooking and to mitigate noise impact from West Cromwell Road

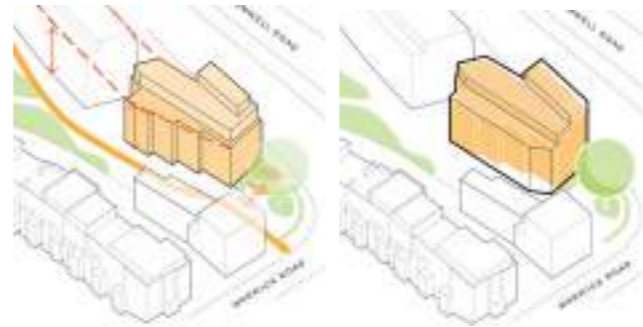

Shoulder height matching adjacent building

Illustrative building form within daylight envelope



Illustrative Ground Floor plan - residential and community use



Illustrative typical Upper Floor plan - residential use



Eye-level view of EC-21 with potential advertising on façade



Eye-level view of EC-21 from West Cromwell Road with a potential artwork (indicative) on the north façade



# 6.5 Warwick Crescent | Built Form

Crescent Plots | Table Plots | Lane Plots | Cluny Mews

## Cluny Mews

The key principles that characterise the Cluny Mews Plot are described in the Design Code. These are demonstrated in the illustrative proposal, including:

- 1** Creating a transition in scale  
The building takes into account the transition from West Cromwell Road to the residences along Philbeach Gardens.
- 2** Integrating the southern façade treatment  
South-facing façades relate to Cluny Mews and their expression enhances its setting.
- 3** Ground floor activation  
Ground Floor frontages onto Cluny Mews should be activated through entrances, residential amenity or through visual permeability.  
  
▶ Refer to Design Code / Warwick Crescent / Built form / Standalone(R) (EC.PA.C).



Key plan

## Illustrative design response



Eye-level view showing Cluny Mews stitching into the surrounding context

# The Table





# 6.6 The Table | Overview

The Table is the centrepiece of the Site around which all the Character Areas converge. It contains the central public open space - the Table Park - and unfolds as a sequence of Exhibition Gardens that enhance biodiversity and showcase a variety of planting characters and outdoor uses.

This section illustrates how the Character Area has been developed alongside the Control Documents. Key principles that characterise the Table are set out on the image on the right.

► Refer to Design Code / The Table (EC.PA.C).



Location of the Table Character Area



A Pivot building strategically located for wayfinding.

Active frontages framing the edges of the public realm.

A landscape embracing the Site conditions and celebrating the level change.

A key east-west route connecting both boroughs.

A destination public open space located at the confluence of key routes.

An urban park with a variety of natural landscaped spaces and gardens.

A potential ecological corridor with the public realm that reconnects nature (subject to third party agreements).

West Brompton station





# 6.6 The Table | Public Realm

The public realm within the Table Character Area is accessible, vehicle-free and formed of a variety of green spaces that support social gatherings, play, and more contemplative activities at the confluence of key routes.

Key spaces and routes are outlined in the Control Documents, including:

The four zones

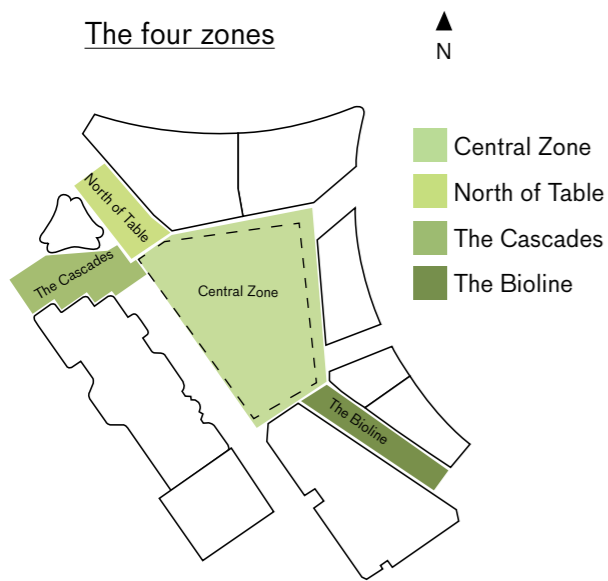

Access and movement

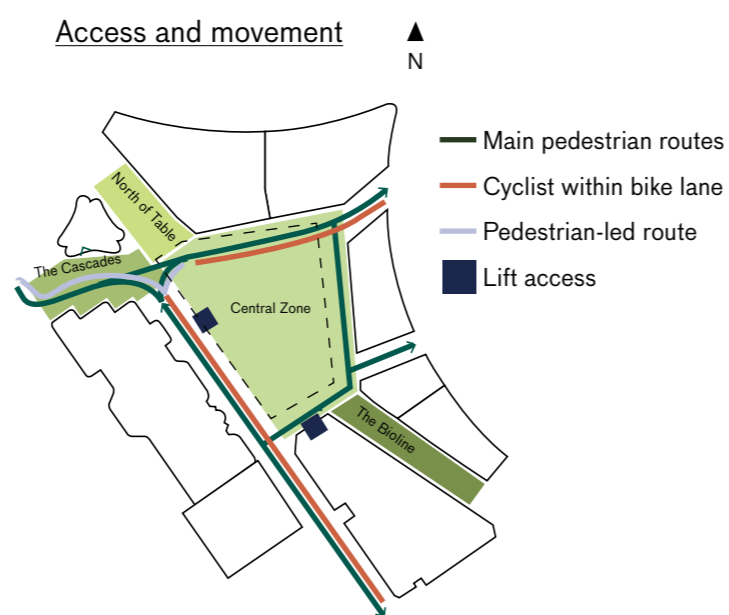

Refer to Design Code / The Table / Landscape / Spaces (EC.PA.C).





# 6.6 The Table | Public Realm

Central Zone | North of Table | The Cascades | The Bioline

## Central Zone

The Central Zone is a destination urban garden formed of a recreational lawn. It is framed by a densely planted area along the western edge of the Table Park, and active frontages that spill onto the public routes surrounding it.

The key principles that characterise the Central Zone are described in the Design Code. These are demonstrated in the illustrative proposal, including:

- A recreational lawn with generous space for picnics, events and recreation.
- A densely planted area to support ecological diversity, offering an immersive experience in nature.
- Active frontages and a hardscape edge for food/beverage with spill-out space.

▶ Refer to Design Code / The Table / Landscape / Central Zone (EC.PA.C).

▶ Refer to Design Code / The Table / Built form / Table facing frontages (EC.PA.C).

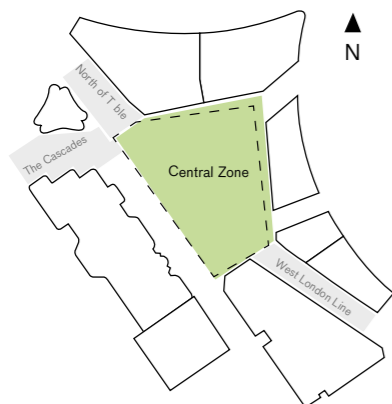

## Illustrative design response



Illustrative plan of the Central Zone



- Hardscaped edges with active frontages and spill-out zones.
- Destination gardens provide usable green areas open to everyone.
- Route for pedestrians and cyclists integrated within the landscape.
- Recreational lawn for picnics, events and informal activities.
- Potential for a Table Pavilion with an integrated lift.
- Denser planting extending ecological habitats from the Bioline onto the Table Park.
- Steps and a lift providing access from Empress Place Boulevard to the Table Park.



Illustrative design response showing distinct areas of the Central Zone



Active edges with spill out zones from cafes and restaurants



Recreational lawn with space for multiple activities



Meandering footpaths



Cycle lane integrated with landscaped areas





## 6.6 The Table | Public Realm

### Central Zone

The key principles that characterise the Central Zone are described in the Design Code. These are demonstrated in the illustrative proposal, including:

- 1** Contributing to biodiversity  
Densely planted areas support ecological diversity and create an immersive experience in nature.
- 2** Creating a lawn for recreation  
A generous space is provided for informal gatherings, sports, and spontaneous uses.
- 3** Creating an events space  
Areas for events to take place are located within the destination gardens, providing a focal point for cultural and community activities.
- 4** Activating the edges of the Central Zone  
Cafés, restaurants and a cultural venue create lively and active edges.

► Refer to Design Code / The Table / Landscape / Central Zone (EC.PA.C).





# 6.6 The Table | Public Realm

Central Zone | North of Table | The Cascades | The Bioline

## North of Table

The North of Table serves as an protected pocket of play space and community use.

The key principles that characterise North of Table are described in the Design Code. These are demonstrated in the illustrative proposal, including:

- A play space with a sense of enclosure.
- A variety of surfaces to suit multiple ages.
- Planting integrated within the space to blend nature and play.
- A balance of sunlit and shaded spaces.

▶ Refer to Design Code / The Table / Landscape / North of Table (EC.PA.C).

▶ Refer to Design and Access Statement Volume 1: Outline Component / Spatial Strategies / Landscape / Play (EC.PA.08).

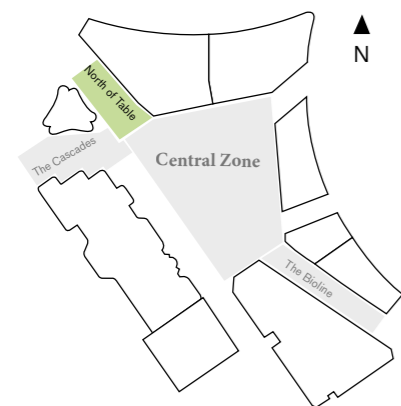

## Illustrative design response

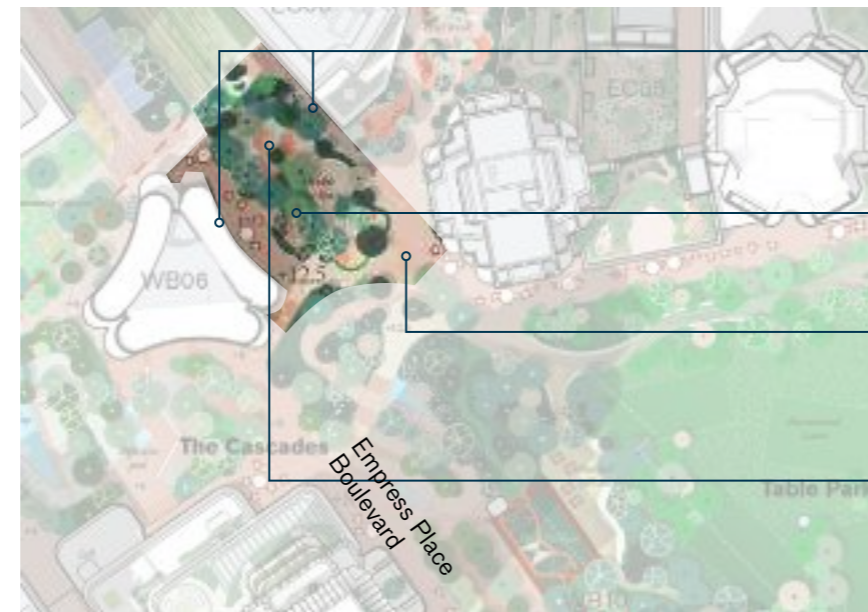

Illustrative plan of the North of Table

- North of Table provides play space for adjacent residential and community uses.
- Hard and soft surfaces for multiple ages.
- Movement routes are arranged around the periphery of the play space.
- Private external play space associated with nursery allocation is provided within the North of Table.



Paving design incorporating hard & soft play surfaces for safe and integrated activity



Eye-level view showing the dedicated nursery play space at the base of the residential building EC O6.



Planting and play spaces blended to integrate with nature



# 6.6 The Table | Public Realm

Central Zone | North of Table | The Cascades | The Bioline

## The Cascades

The Cascades provide an accessible and inclusive landscape destination with flowing water features that navigate and celebrate the Site's level change.

The key principles that characterise the Cascades are described in the Design Code. These are demonstrated in the illustrative proposal, including:

- A water feature that invites play.
- An accessible level change that makes ramps and steps an integral part of the landscape.
- A seamless approach to landscape and building design that softens the transition between inside and outside.
- A sustainable approach to rainwater management and irrigation that also embraces the sensory benefits of water.

▶ Refer to Design Code / The Table / Landscape / The Cascades (EC.PA.C).

▶ Refer to Design and Access Statement Volume 1: Outline Component / Spatial Strategies / Landscape / Water / The Cascades (EC.PA.08).

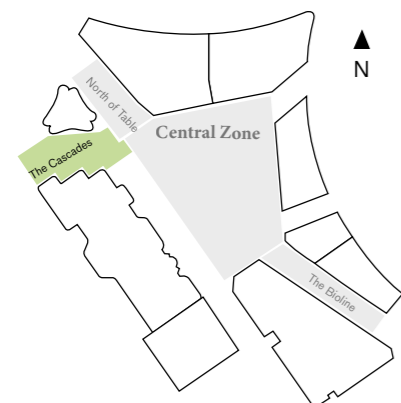

## Illustrative design response



View of the base of the Cascades and Detailed Plot WBO4 beyond



Water features incorporate planting and play space



Cascading water aids wayfinding

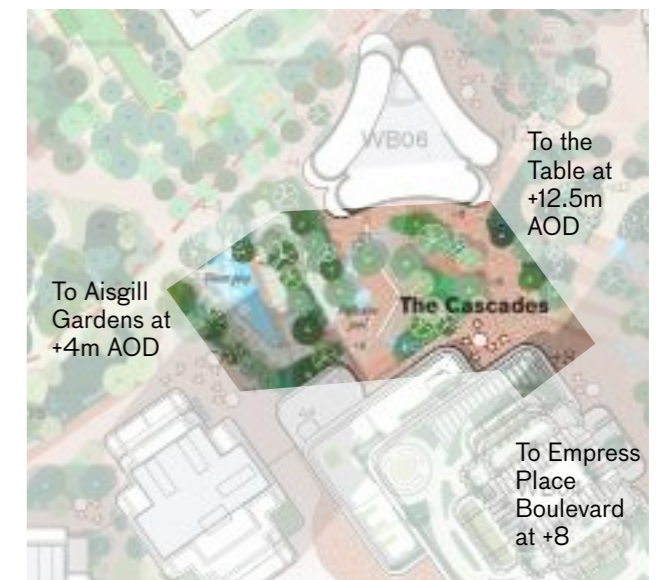
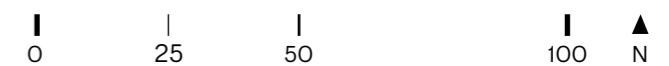

Illustrative plan showing the Cascades



## 6.6 The Table | Public Realm

Central Zone | North of Table | The Cascades | The Bioline

### The Cascades

The key principles that characterise the Cascades are described in the Design Code. These are demonstrated in the illustrative proposal, including:

- 1** Celebrating the level change  
The terraced landscape makes water and planting key features of the level change.
- 2** Integrating landscape with buildings  
Plateaus are aligned with building entrances to provide level access.
- 3** Creating accessible routes in all directions  
Accessible and step-free routes facilitate the movement across levels of people of all abilities as well as cyclists.
- 4** Interacting with water  
A sequence of filtration ponds combines functional water management and reuse with water play.

► Refer to Design Code / The Table / Landscape / The Cascades (EC.PA.C).



Key plan

### Illustrative design response



Aerial view showing the terraced landscape of the Cascades



# 6.6 The Table | Public Realm

Central Zone | North of Table | The Cascades | The Bioline

## Accessibility

The Cascades provide an accessible step-free connection between the levels of the Table (+12.5m AOD), Empress Place Boulevard (+8m AOD) and Aisgill Gardens (+4m AOD).

Level changes have been addressed with the shallowest gradients possible. Intermediate level landings are provided every 500mm rise for 1:21 slopes and every 5m for 1:15 ramps. Landings are larger than the minimum required by access standards to provide a place to rest but also to enjoy the landscape.

The path width has been sized to create a safe environment for pedestrians and cyclists to share the access route.

Public lifts are proposed to provide an alternative means of access across the level change. These have been located strategically to provide a direct route between levels and are easily identifiable.

- ▶ Refer to Design and Access Statement Volume 1: Outline Component / Spatial Strategies / Access (EC.PA.08).
- ▶ Refer to Design Code / The Table / Landscape / The Cascades / Accessible level change (EC.PA.C).



Illustrative aerial view of the Cascades and the podium of WBO4

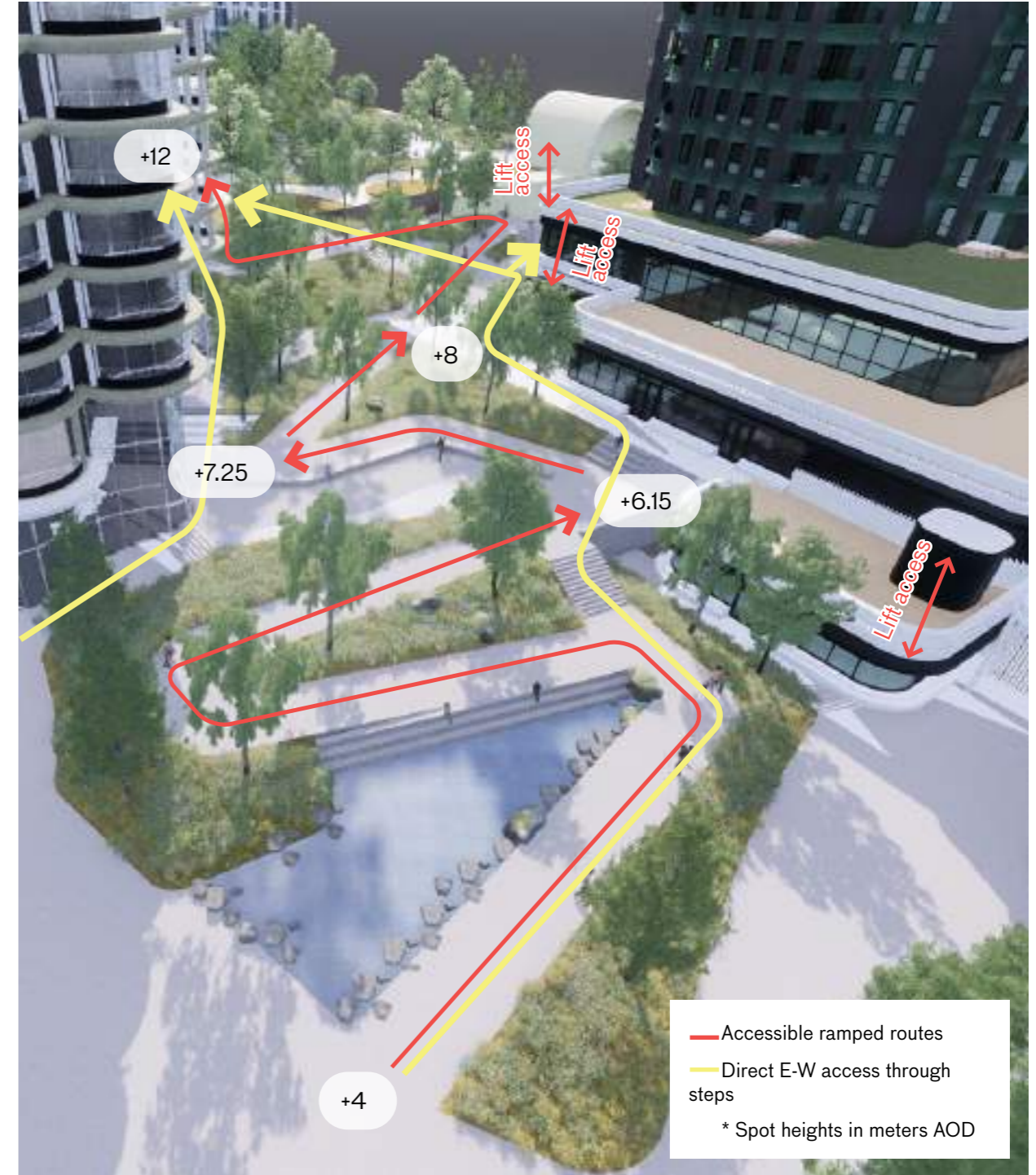

Illustrative diagram showing the integration of accessible routes for all users



# 6.6 The Table | Public Realm

Central Zone | North of Table | The Cascades | The Bioline

## The Bioline

The potential Bioline extends the Brompton Cemetery ecological habitats into the Site and helps create a strong north-south biodiversity corridor along the West London Railway Line.

The key principles that characterise the Bioline are described in the Design Code. These are demonstrated in the illustrative proposal, including:

- Enhancing the existing ecological corridor that connects the West London Railway Line Site of Importance for Nature Conservation (SINC) and the Brompton Cemetery.
- Exploring the possibility to deck-over the West London Railway Line to deliver a linear landscape and enhanced ecological corridor.\*
- Creating pedestrian access to the Table Park from West Brompton Square alongside extensive planting.

\*Decking over of the West London Railway Line is subject to third party agreement.

▶ Refer to Design Code / The Table / Landscape / The Bioline (EC.PA.C).

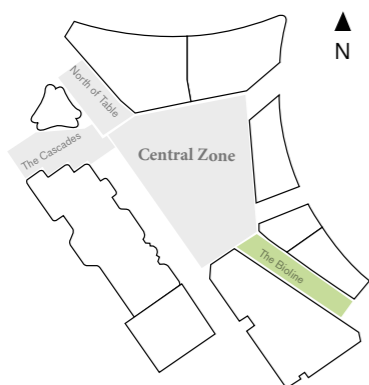

## Illustrative design response



Illustrative plan showing the potential Bioline



Intensive planting on the Bioline could connect with existing areas of ecological value such as Brompton Cemetery.

Paths on both sides can provide pedestrian and cycle routes as well as emergency vehicle access.

The Bioline could extend and stitch in with West Brompton Square creating a continuous green corridor.



The Bioline offers the opportunity to cover over the West London Railway Line and enhance the existing SINC



Eye-level view showing the entrance to the potential Bioline



A green link connects existing ecological corridors.

Culture, cafés and restaurants spill-out and activate the Table Park.

A densely planted area supports ecological diversity and encourages a human connection with nature.

A generous space for informal gatherings and sports.

Eye-level view of the Table Park



# 6.6 The Table | Built Form

A variety of building typologies frame the public realm of the Table, forming a continuous frontage that activates and enlivens it.

The Illustrative Masterplan responds to key built form principles outlined in the Control Documents:

- Framing the public realm with active Ground Floor frontages and varied building façades.
- Sculpting built form to allow sunlight to penetrate the central open spaces.
- Strategically locating a landmark building (the 'Pivot') at the confluence of the east-west and north-south routes.
- Positioning a Pavilion on the western edge of the Table to activate the open space and provide life access from Empress Place Boulevard.

The Table is comprised of the following built form typologies:

- Pivot
- Pavilion
- Table-facing frontages

▶ Refer to Design Code / The Table / Built form (EC.PA.C).

▶ Refer to Development Specification (EC.PA.A).

The below plans outline the land use emphasis of the Illustrative Masterplan within the Character Area. Full detail of the permitted land uses are described in the Development Specification.

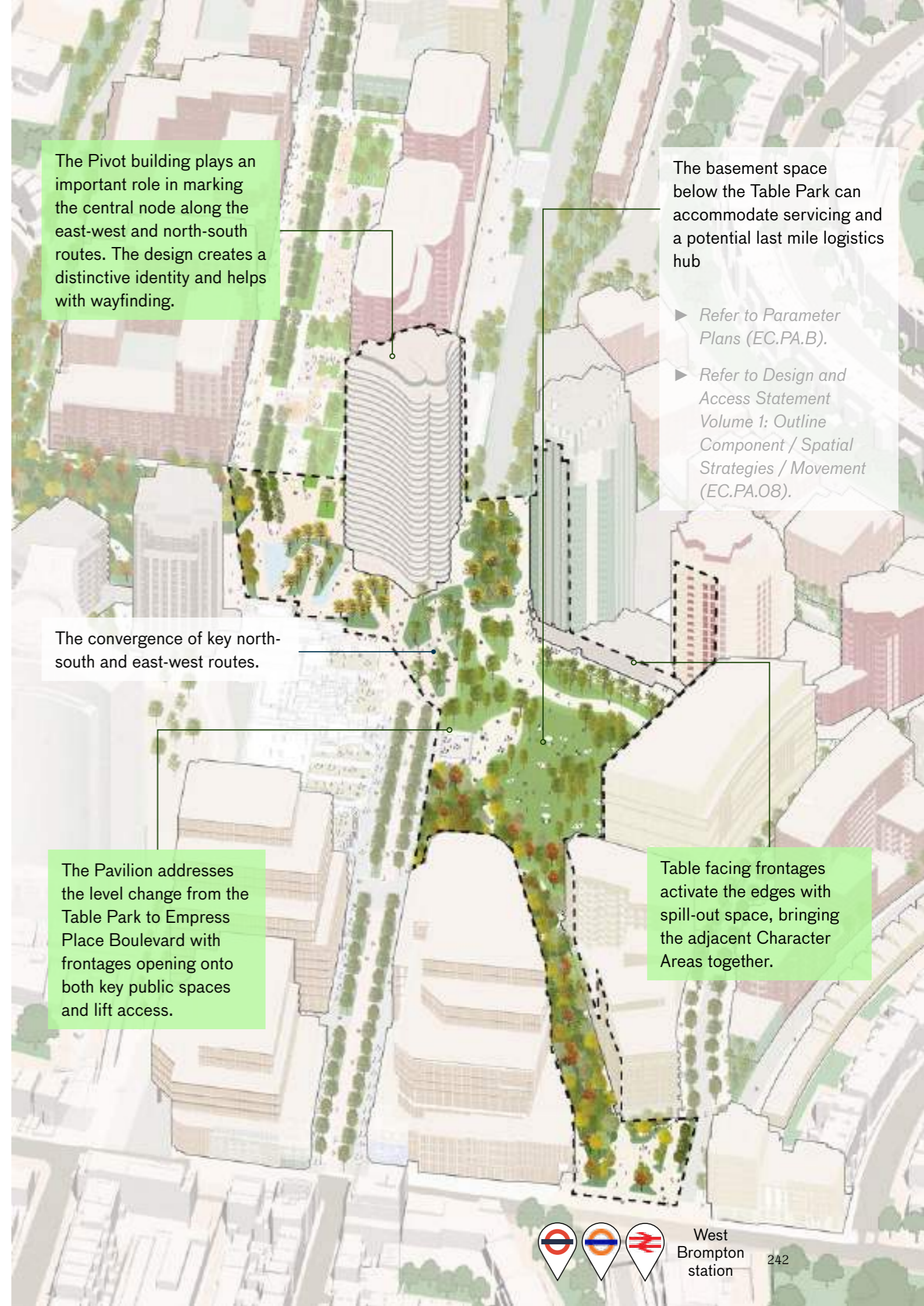
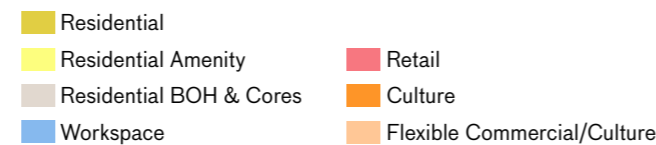
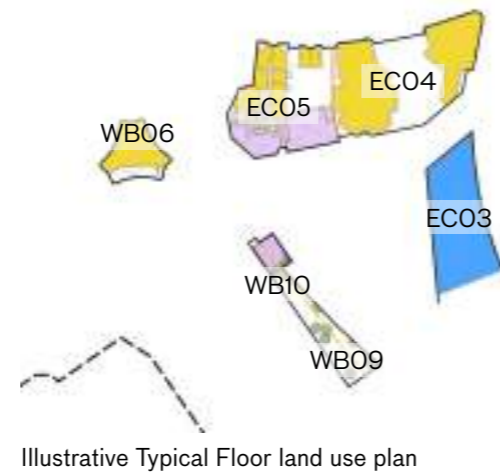
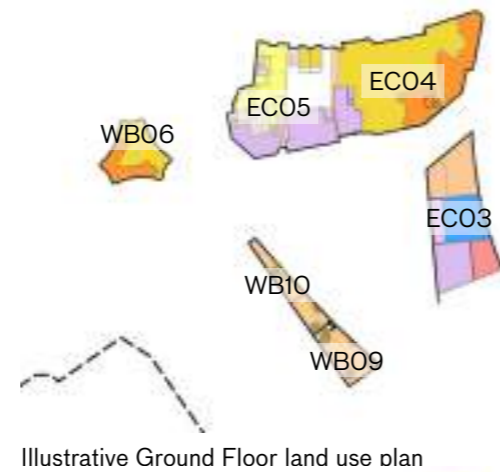

The Pivot building plays an important role in marking the central node along the east-west and north-south routes. The design creates a distinctive identity and helps with wayfinding.

The basement space below the Table Park can accommodate servicing and a potential last mile logistics hub

- ▶ Refer to Parameter Plans (EC.PA.B).
- ▶ Refer to Design and Access Statement Volume 1: Outline Component / Spatial Strategies / Movement (EC.PA.08).

The convergence of key north-south and east-west routes.

The Pavilion addresses the level change from the Table Park to Empress Place Boulevard with frontages opening onto both key public spaces and lift access.

Table facing frontages activate the edges with spill-out space, bringing the adjacent Character Areas together.



# 6.6 The Table | Built Form

Pivot Building | Pavilion | Table facing frontages

## The Pivot building

Plot Code: WBO6  
Typology: Pivot building

The Pivot building marks the confluence of the key north-south and east-west routes. Its location and role as a landmark have informed its distinctive shape.

The key principles that characterise the Pivot building are described in the Design Code. These are demonstrated in the illustrative proposal, including:

- A triangular form offering a faceted elevation that accentuates the point of confluence.
- Soft, curved façades and corners addressing key routes and vistas.
- Ground floor façades framing the public realm and animating it with visible cultural programming.
- Building articulation is led by the landscape.

► Refer to Design Code / The Table / Built form / Pivot (EC.PA.C).

## Illustrative design response



Maximum envelope defined by the Parameter Plans



Corners accentuated with curved balconies

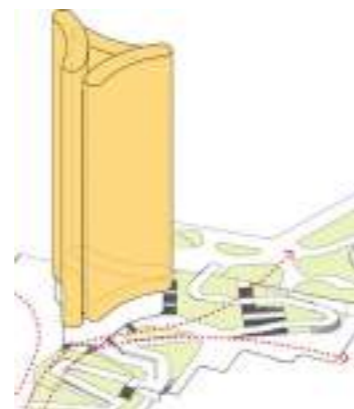

Triangular form responds to crossing point



Base of tower set back to integrate with landscape



Slender form comprised of three curved elements



Stepped-back landscaped roof terraces

Cultural & social space Entrances at Boulevard (+08m) and Aisgill Gardens (+04m)



Lower Ground Floor plan - mixed-use

Triangular form with concave façade Bull-nose balconies accentuate corners

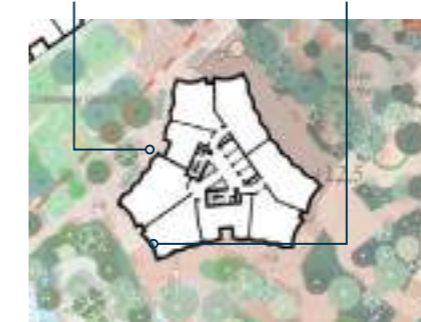

Typical Upper Floor - residential use

0 10 25 50 N



Illustrative eye-level view showing the Pivot building at the confluence of Empress Place Boulevard and the Table

Residential entrances at the Table Park level (+12.5m AOD)

Façade set back and glazed to reveal interior

Interior and exterior levels match to allow for movement between public realm and Ground Floors



Illustrative eye-level view showing the Pivot building base activating the public realm levels along the Cascades



# 6.6 The Table | Built Form

Pivot building | Pavilion | Table Facing Frontages

## Pavilion

Plot Code: WB10  
Typology: Pavilion

The Pavilion is a flexible building designed for flexible use. It activates the Table Park and serves as its focal point.

The key principles that characterise the Pavilion are described in the Design Code. These are demonstrated in the illustrative proposal, including:

- Providing a playful and memorable marker and focal point.
- Creating a flexible space for retail, food and beverage, or temporary uses.
- Providing a built structure that helps address the level change and incorporates a lift.
- Providing a sheltered space for use throughout the year.

► Refer to Design Code / The Table / Built form / Pavilion (EC.PA.C).

## Illustrative design response

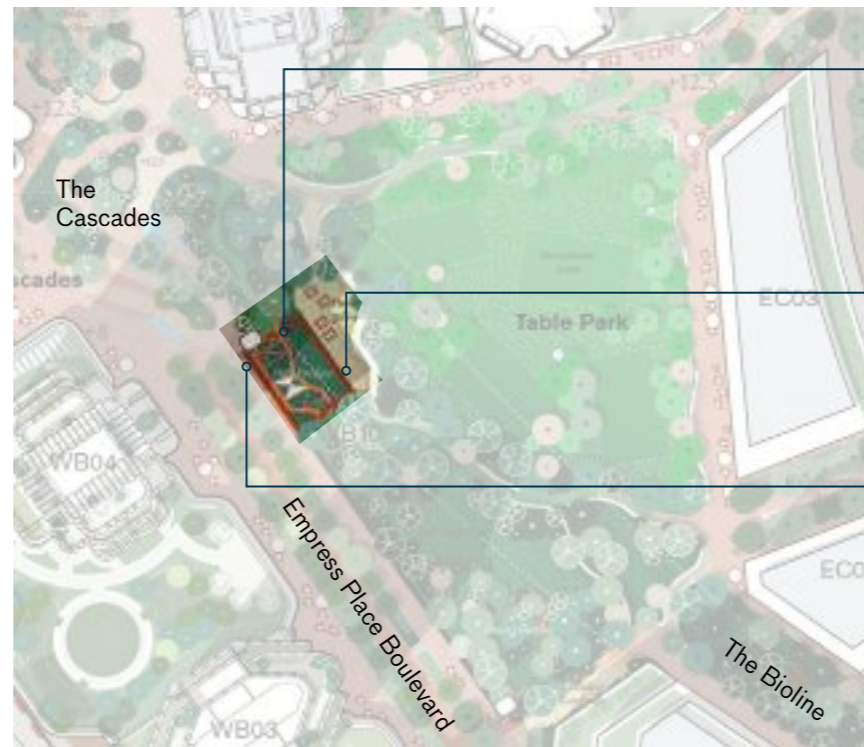

Illustrative location of the potential Pavilion

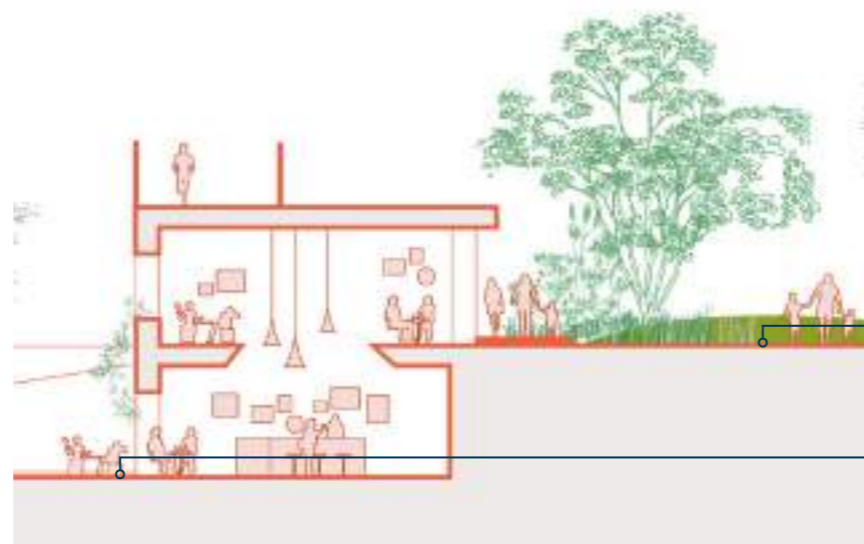
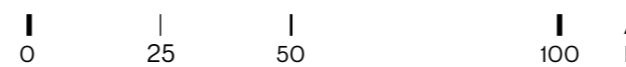

Illustrative section of the potential Pavilion

A key focal point that addresses both sides: Table Park and Empress Place Boulevard.

Flexible space can act as a backdrop to events on the Table Park.

Integration of a lift to address the level change.



Pavilion design that allows flexible use



Pavilion design that encourages playfulness



Example of integration of lift access to assist with the level change



## 6.6 The Table | Built Form

Pivot building | Pavilion | Table facing frontages

### Table-facing frontages

Façades framing the Table are permeable and their uses spill onto the public realm to encourage movement and activation where buildings interface with the landscape.

Buildings surrounding the Table Park are contained within several Character Areas. Park-facing frontages have common requirements, including:

- Prioritising transparency and visual connection to the public realm.
- Locating cafés, restaurants, culture and community-focused spaces to promote spill-out and activation.
- Providing sheltered areas for year-round activity.
- Addressing the level change through built form where appropriate.

► Refer to Design Code / The Table / Built form / Table facing frontages (EC.PA.C).

### Illustrative design response

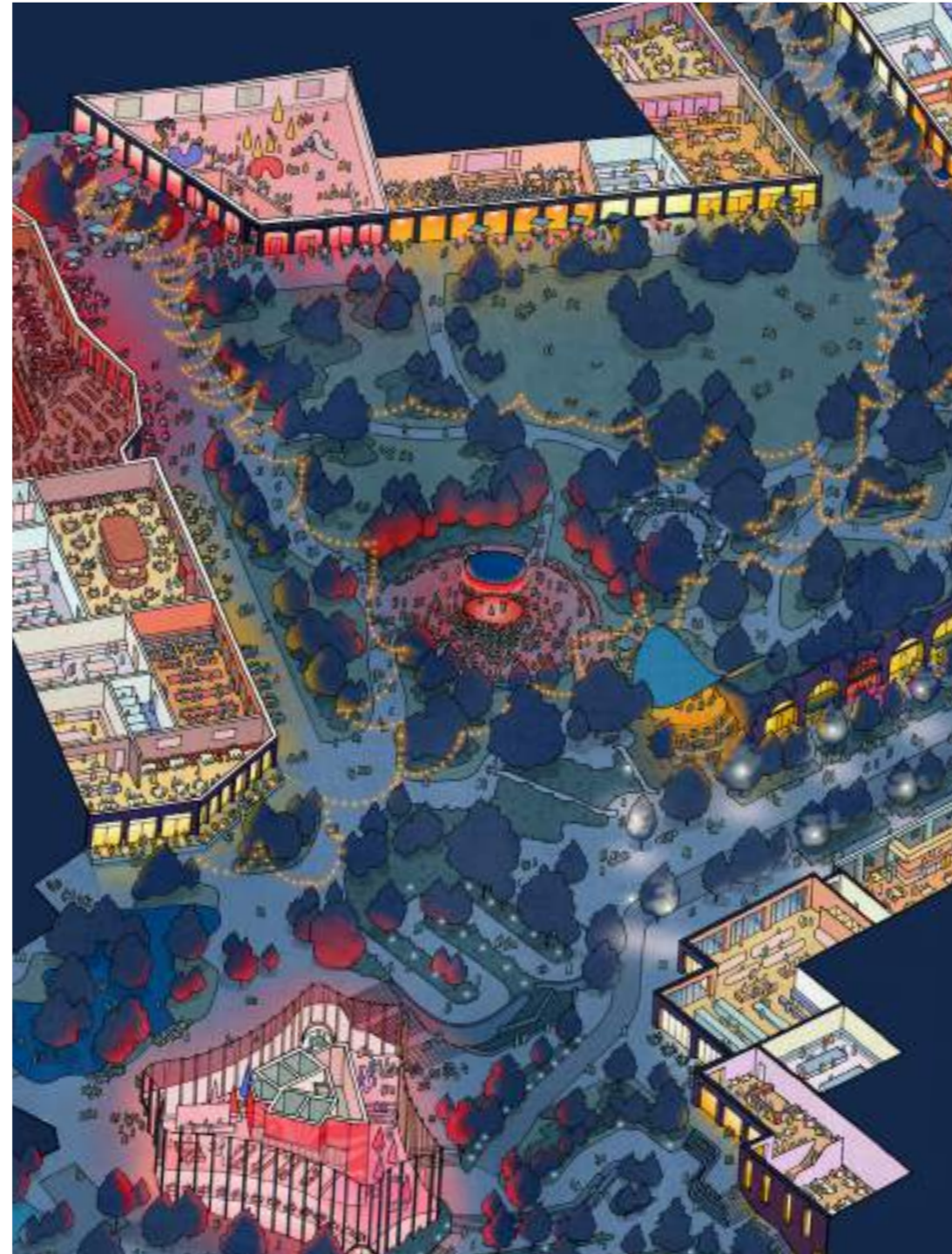

Illustrative Design Response showing the façades addressing the Table Park



Active frontages are continuous at podium and the Table Park interfaces



Key cultural uses are celebrated at the Table Park's edges



The Table is framed by residential and commercial buildings.

A mix of typologies and tenures provides an opportunity for a range of homes for all stages of life.

Culture and dining spilling out at Ground Floor level.

A sequence of Exhibition Gardens showcases biodiversity, planting and varied landscape uses.

A variety of green spaces for socialising, relaxing, playing and gathering.

# Empress Place





# 6.7 Empress Place | Overview

Adjacent to West Brompton station, Empress Place is a key gateway to the Site and includes one of three innovation clusters, a cultural venue and a mix of new homes.

This section illustrates how the Character Area has been developed alongside the Control Documents. Key principles that characterise Empress Place are set out on the image on the right.

► Refer to Design Code / Empress Place (EC.PA.C).

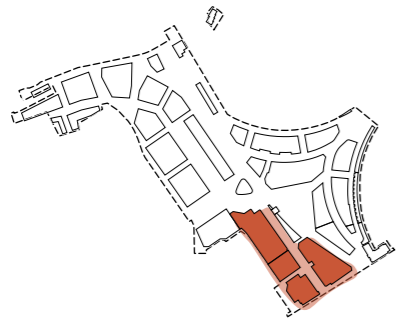

Location of West Brompton Character Area

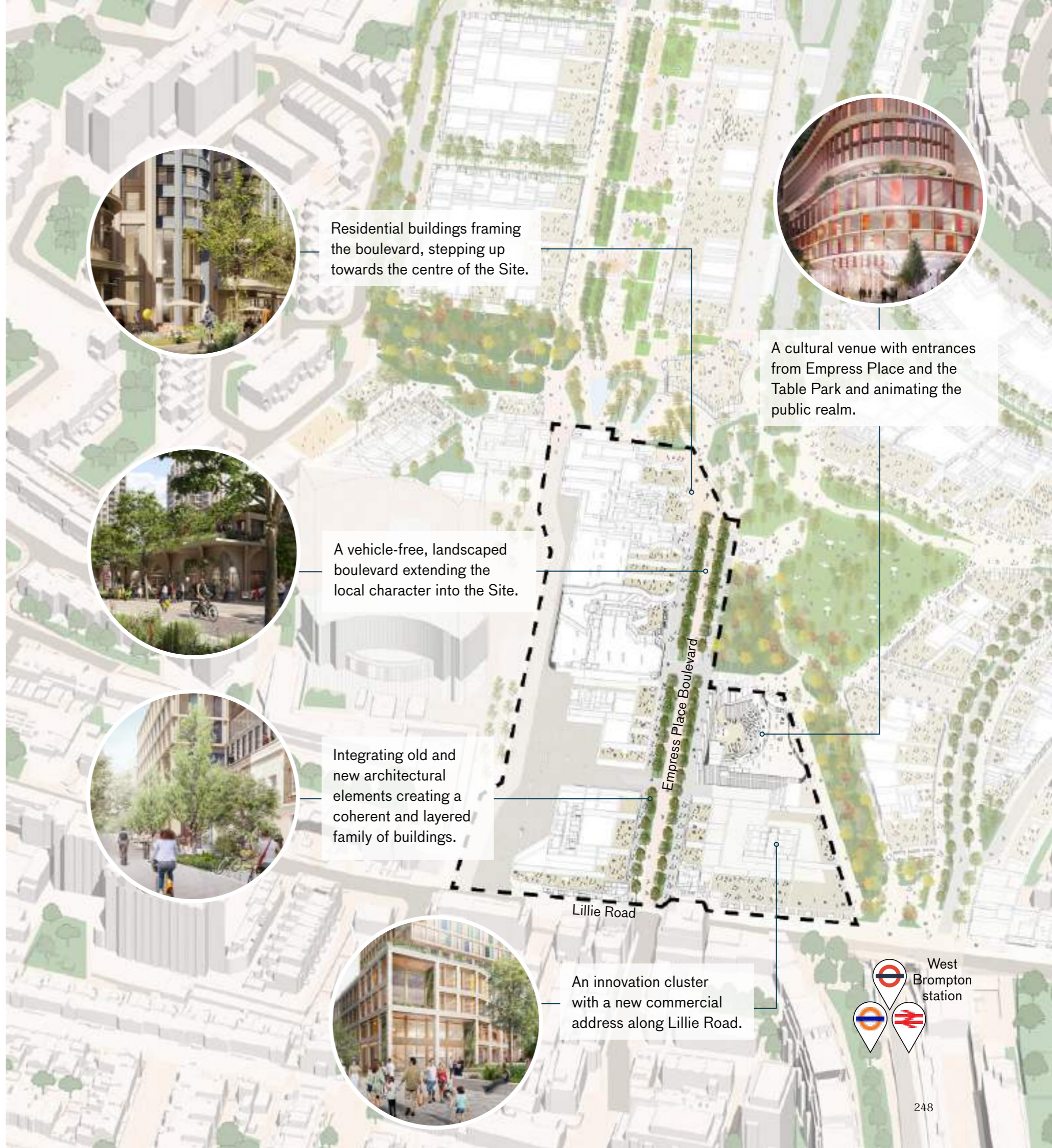

Residential buildings framing the boulevard, stepping up towards the centre of the Site.



A cultural venue with entrances from Empress Place and the Table Park and animating the public realm.



A vehicle-free, landscaped boulevard extending the local character into the Site.



Integrating old and new architectural elements creating a coherent and layered family of buildings.



An innovation cluster with a new commercial address along Lillie Road.



# 6.7 Empress Place | Public Realm

Empress Place Boulevard is a grand, tree-lined, vehicle-free street that links Lillie Road to the Cascades. At 850 metres long, it will be about the length of Regent Street from Oxford Circus to Piccadilly Circus.

Key spaces and routes are outlined in the Control Documents including:

### Spaces and routes

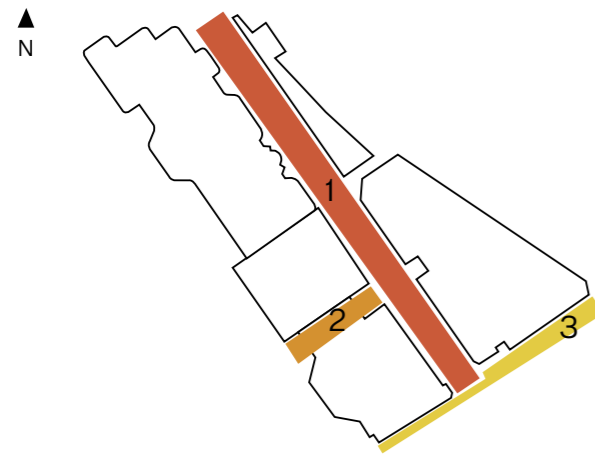

- 1** Empress Place Boulevard
- 2** Empress Place Passage
- 3** Lillie Road Edge

### Access and movement

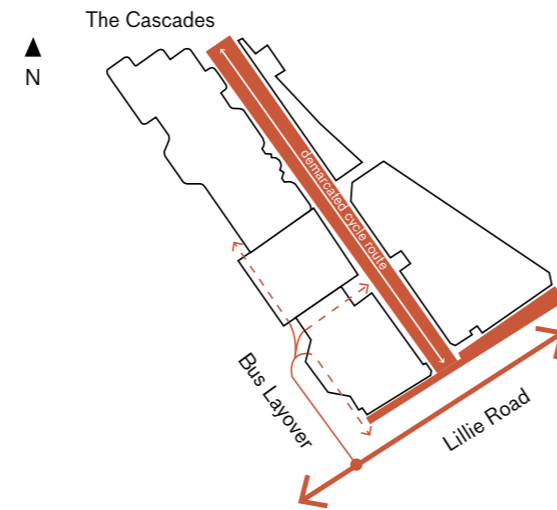

- Vehicle free public realm (cyclist on demarcated route)
- Vehicle access
- -> Vehicle access within undercroft

- ▶ Refer to Design Code / Empress Place / Landscape (EC.PA.C).
- ▶ Refer to Design Code / Sitewide / Landscape (EC.PA.C).

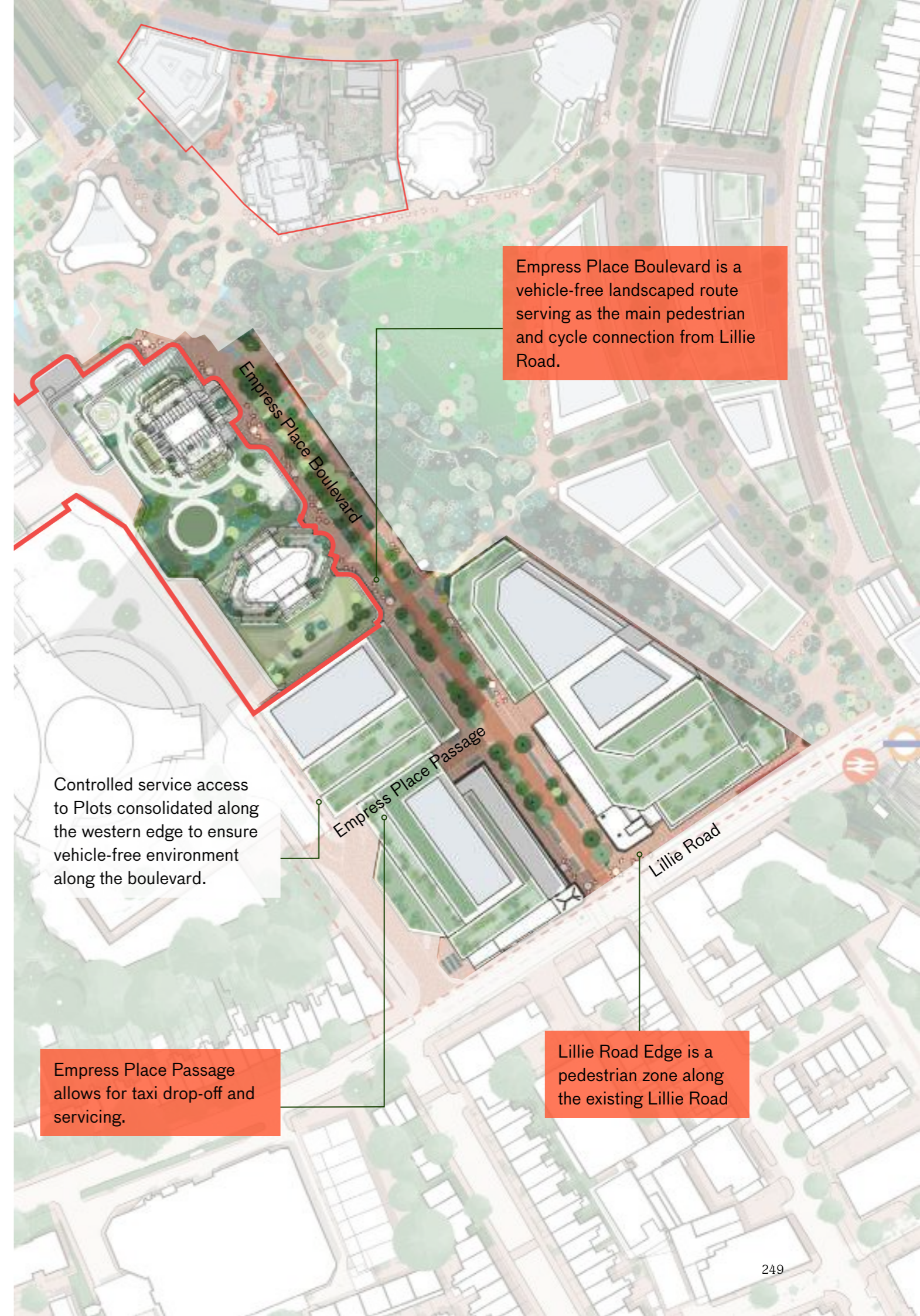

Empress Place Boulevard is a vehicle-free landscaped route serving as the main pedestrian and cycle connection from Lillie Road.

Controlled service access to Plots consolidated along the western edge to ensure vehicle-free environment along the boulevard.

Empress Place Passage allows for taxi drop-off and servicing.

Lillie Road Edge is a pedestrian zone along the existing Lillie Road



# 6.7 Empress Place | Public Realm

Edge | Boulevard | Passage

## Lillie Road edge

Lillie Road provides two pedestrian routes into the Site at West Brompton Square and Empress Place Boulevard.

The proposal enhances the public realm along Lillie Road from its current condition of narrow pavements.

The key principles that characterise Lillie Road Edge are described in the Design Code. These are demonstrated in the illustrative proposal, including:

- Widening the pavement between Empress Place Boulevard and West Brompton station, catering for the anticipated increase in footfall and enhancing safety and wellbeing.
- Adding a segregated cycle lane to ensure a safe connection for cyclists to the wider active travel network.
- Activating Lillie Road frontages with retail, food and beverage and commercial space.

▶ Refer to Design Code / Empress Place / Lillie Road Edge (EC.PA.C).

▶ Refer to Transport Assessment / Mitigation (EC.PA.13).

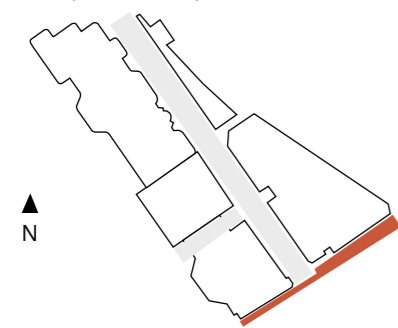

## Illustrative design response

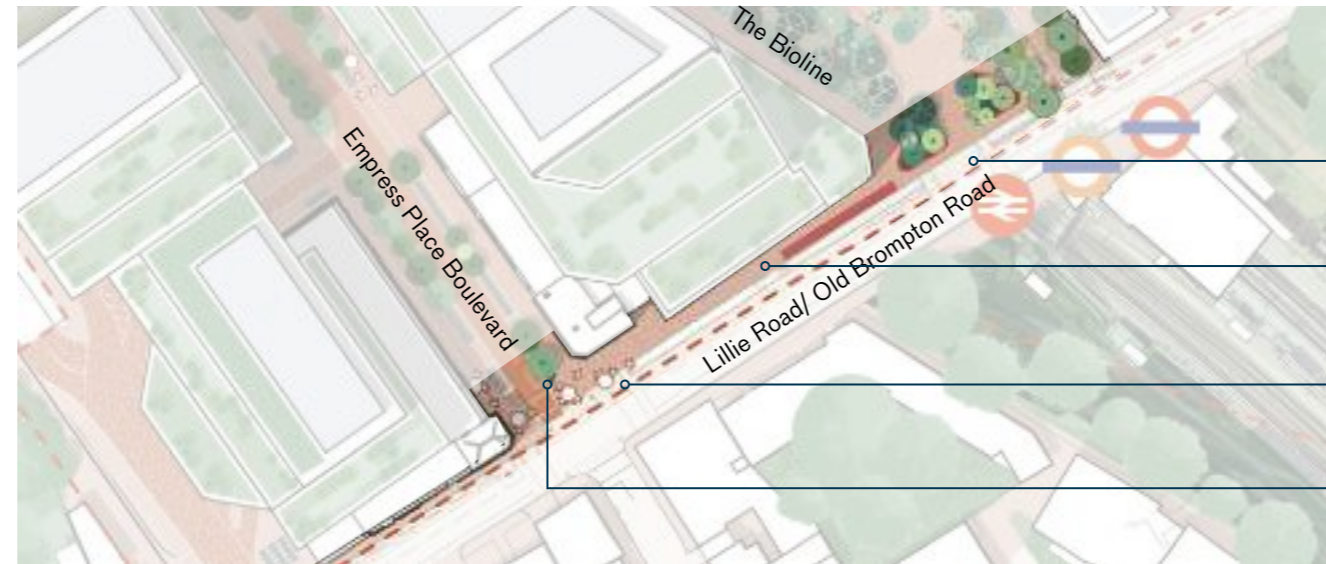

Illustrative public realm plan showing Lillie Road edge

- Widened crossing at West Brompton station
- Widened footway provision adjacent to proposed development
- Proposed cycle lane provisions
- Signalled junction required at Empress Place Boulevard/Lillie Road



Eye-level view showing widening along Lillie Road edge



Eye-level view of Lillie Road showing the existing shops





# 6.7 Empress Place | Public Realm

Edge | Boulevard | Passage

## Empress Place Boulevard

A mixed-use street with well-defined building alignments creates a vibrant and legible environment that establishes a visual connection with the Table Park.

The key principles that characterise Empress Place Boulevard are described in the Design Code. These are demonstrated in the illustrative proposal, including:

- Extending the existing street to form an active southern entrance into the Site.
- Connecting with the Cascades to the north, at the confluence of the key north-south and east-west routes.
- Enhancing the existing street, Empress Place, with landscape to provide a pedestrian-priority active environment.
- Framing the route with workspaces, homes, shops and creative spaces.
- Providing a key cultural venue at the centre of the boulevard, animating the public realm and signalling a connection with the Table Park.

► Refer to Design Code / Empress Place / Empress Place Boulevard (EC.PA.C).

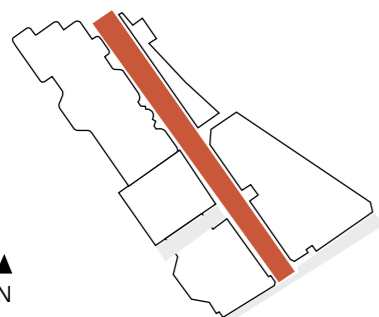

## Illustrative design response

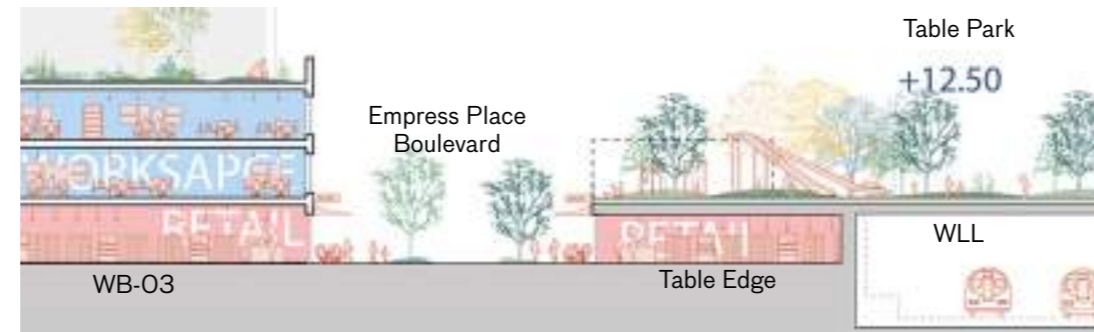

Diagrammatic section of Empress Place Boulevard

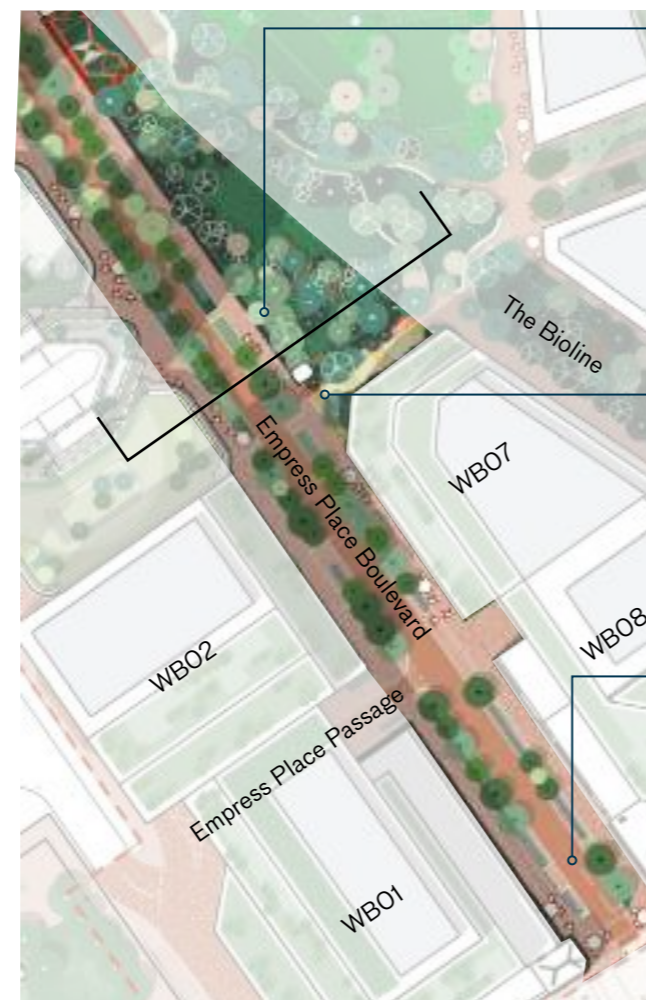

Illustrative plan showing the Empress Place Boulevard



### Table Edge

Below the Table Park, the level difference allows for small scale cafés, shops and cultural spaces within the Table Edge to create active frontages along the boulevard.

### Connecting to the Table Park

Pedestrian access from the boulevard to the Table Park creating the potential for an entrance to the cultural venue in WBO7.

### Extending local character

Enabling the retention and integration of the existing Empress Place frontages allows emerging proposals to stitch in and extend the existing streetscape.



Eye-level view of Empress Place Boulevard



## 6.7 Empress Place | Public Realm

Edge | Boulevard | Passage

### Empress Place Boulevard Illustrative design response

The key principles that characterise Empress Place Boulevard are described in the Design Code. These are demonstrated in the illustrative proposal, including:

- 1** Extending local character  
A two-sided street builds on the local character and extends a familiar street typology into the Site.
- 2** Prioritising people and cyclists  
Empress Place Boulevard is a vehicle-free street with a cycle lane and widened, planted pedestrian zones.
- 3** Responding to the Victorian terraces  
Terrace frontages frame the start of the boulevard and define an intermediate datum line that defines the human scale.
- 4** Creating climate resilient streetscapes  
Tree-lined streets to reduce the heat island effect and create a better micro climate while improving air quality.

► Refer to Design Code / Empress Place / Empress Place Boulevard (EC.PA.C).



Key plan



Eye-level view of Empress Place Boulevard from Lillie Road



# 6.7 Empress Place | Public Realm

Edge | Boulevard | Passage

## Empress Place Passage

Empress Place Passage incorporates the existing bus stand and makes provisions for taxi drop-off and safe movement of pedestrians.

The key principles that characterise Empress Place Passage are described in the Design Code. These are demonstrated in the illustrative proposal, including:

- Reconfigured bus facilities to accommodate additional vehicular demand and allow for buildings above.
- Consolidating the junction with Lillie Road into a single access point and prioritising pedestrian comfort and safety.
- Controlling access into the Detailed Components WBO3-04 podium, allowing for taxi drop-off and facilitating servicing access to the residential buildings deeper within the Site.

▶ Refer to Design Code / Empress Place / Empress Place Passage (EC.PA.C).

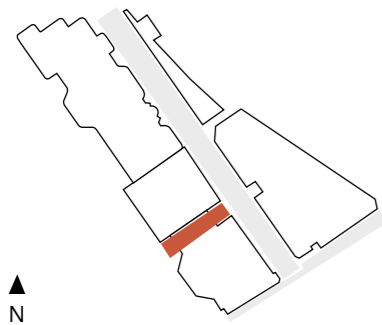

## Illustrative design response



Illustrative precedent for taxi drop-off and bus stands incorporated with building under-crofts

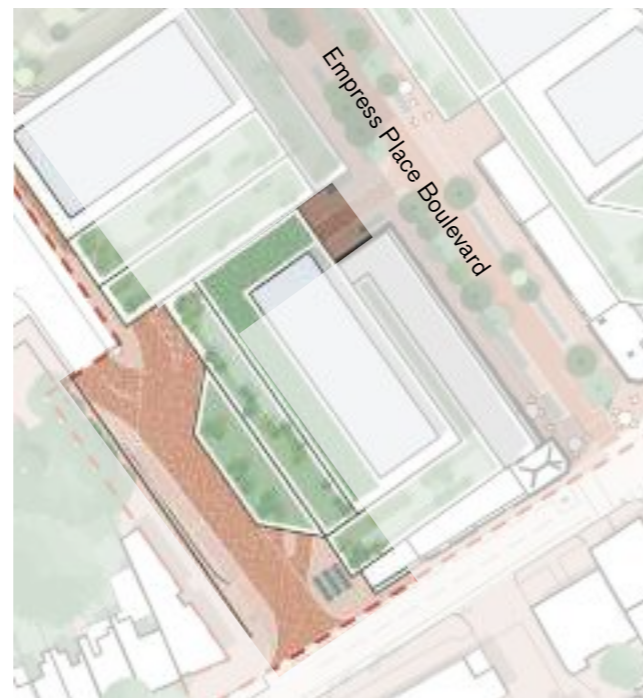
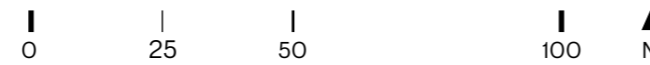

Illustrative plan showing the Empress Place Passage

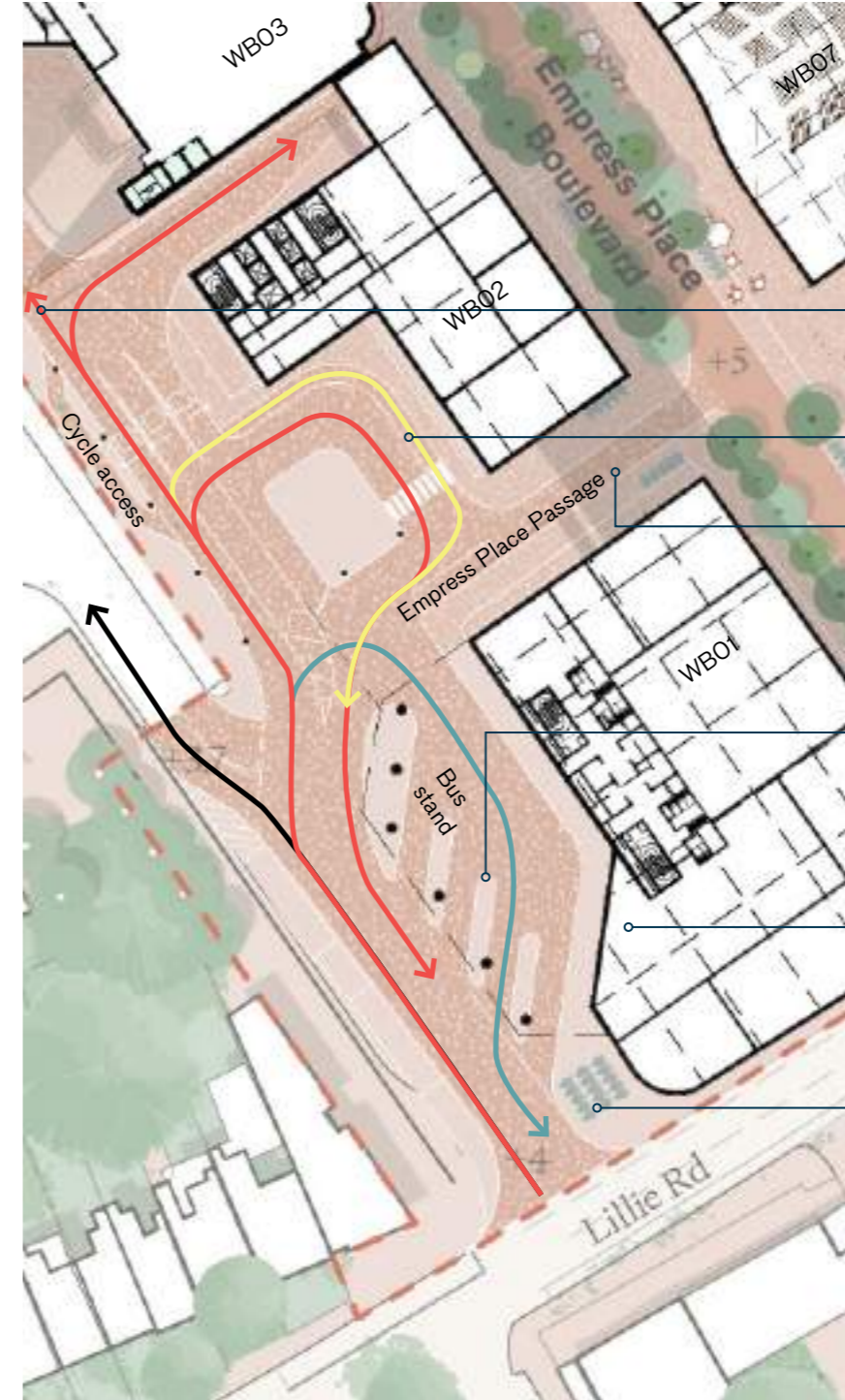

- Access to MOPAC
- Access to WBO1-08
- Taxi routing
- Bus routing

Controlled Vehicular Access Point to WBO3-06

Taxi drop-off

Controlled vehicular access

Reconfigured bus stand layout

Existing bus welfare facilities re-provided within Ground Floor of proposed building

Enlarged pedestrian footway enabled through consolidated vehicular entrance

Illustrative plan showing proposed Ground Floor vehicular routes layout



# 6.7 Empress Place | Built Form

Empress Place built form is characterised by the workspace buildings which create a southern gateway cluster, the Table Edge that animates the public realm and the residential buildings that step up towards the middle of the Site and frame the Table Park.

The Illustrative Masterplan responds to key built form principles outlined in the Control Documents including:

- Integrating old and new buildings to form a key gateway and workspace cluster.
- Creating a variety of floor plates suitable for a range of businesses from burgeoning start ups to established institutions.
- Stepping building heights from the Site edge to the tallest landmark residential building.
- Creating a Table Edge mediating between Empress Place Boulevard and the Table Park.

Empress Place is comprised of the following built form typologies:

- Large-footprint
- Table Edge
- Residential buildings (Detailed Components)

▶ Refer to Design Code / Empress Place / Built form (EC.PA.C).

▶ Refer to Design Code / Sitewide / Built form (EC.PA.C).

▶ Refer to Development Specification (EC.PA.A).

The below plans outline the land use emphasis of the Illustrative Masterplan within the Character Area. Full detail of the permitted land uses are described in the Development Specification.

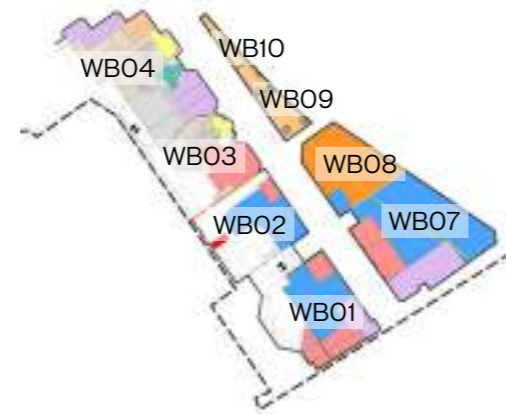

Illustrative Ground Floor land use plan

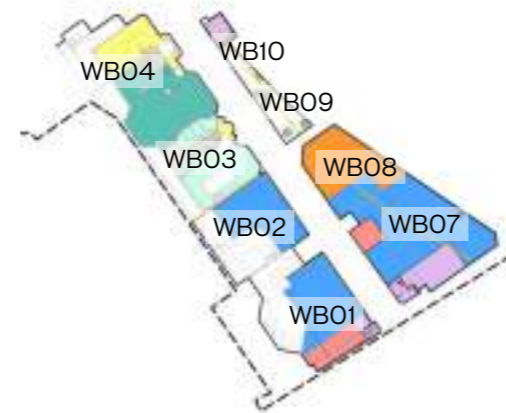

Illustrative Typical Upper Floor land use plan



Residential buildings (Detailed Components) form a key component of the approach to height within the masterplan, and helps define the Empress Place Character Area.  
▶ Refer to Design and Access Statement Volume 3: LBHF Detailed Component (EC.LBHF.02).

The Table Edge occupies a space that mediates the level change between street and the Table Park. It forms a series of shops and cafés along Empress Place Boulevard which provide active frontages and helps manage the level change to the Table Park.

As one of the three innovation clusters, these large footprint workspace buildings incorporate historic terraces and step up in height toward the residential buildings.

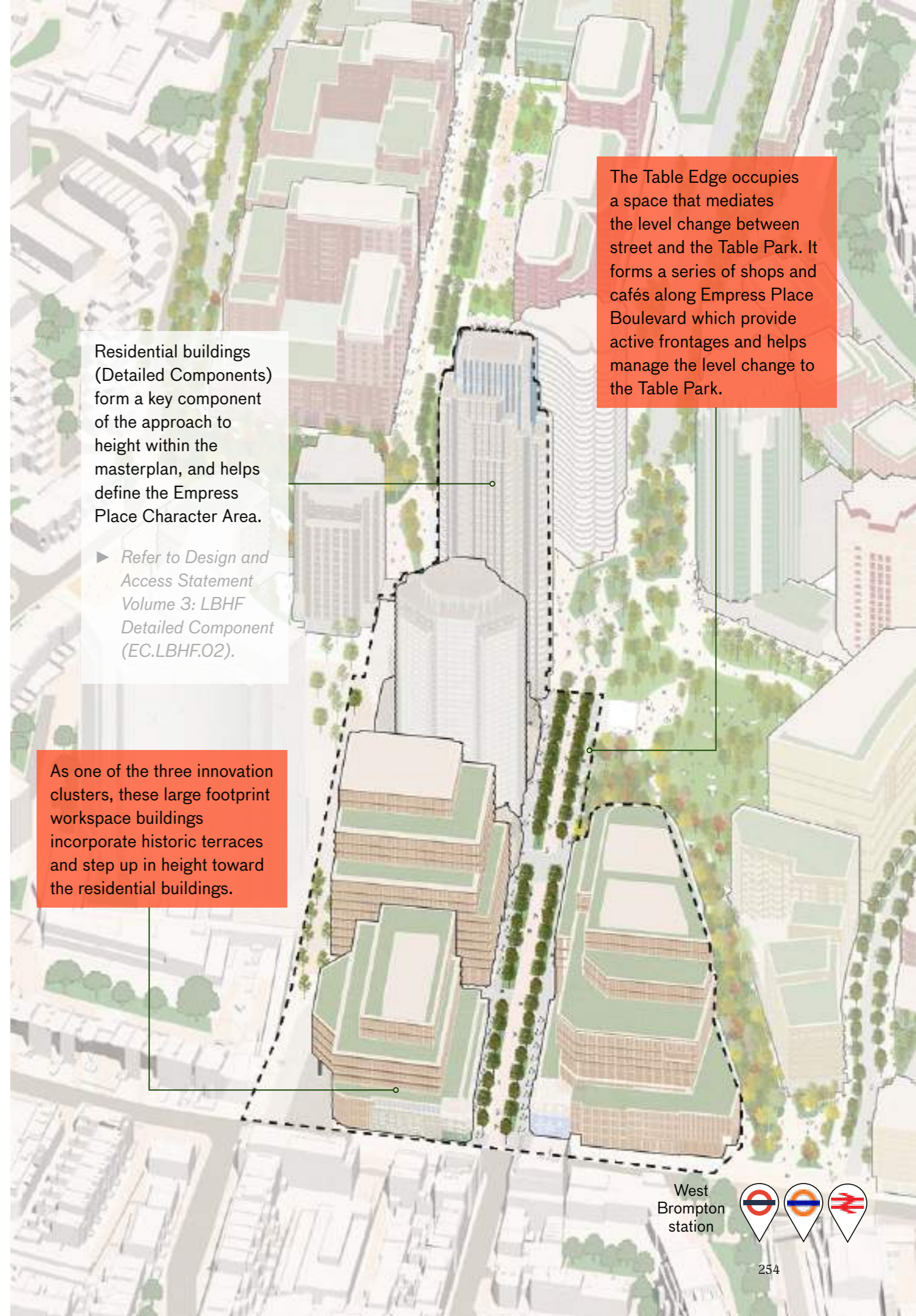



# 6.7 Empress Place | Built Form

Workspace cluster | The Table Edge

## Workspace cluster

Plot Code: WB01, WB02, WB07, WB08  
Typology: Large-footprint

The workspace cluster includes a variety of commercial spaces creating a southern gateway to the Site in a layered composition of old and new buildings.

The key principles that characterise the workplace cluster are described in the Design Code. These are demonstrated in the illustrative proposal, including:

- Creating an exciting and innovative campus that marks the entrance to the Site.
- Maintaining the existing character of Lillie Road and Empress Place through partial retention of the existing façades.
- Forming a 3-4 storey horizontal expression, from which a series of commercial buildings emerge.
- Creating a family of buildings that strikes a balance between individual expression and familiarity to create a layered composition.
- Marking the presence of key cultural anchors at the Table Park.
- Creating a series of terraces on setback levels, contributing to the sitewide landscape strategy and with the potential for public access.

► Refer to Design Code / Empress Place / Building typologies / Large-footprint (EC, P.A.C).

## Illustrative design response

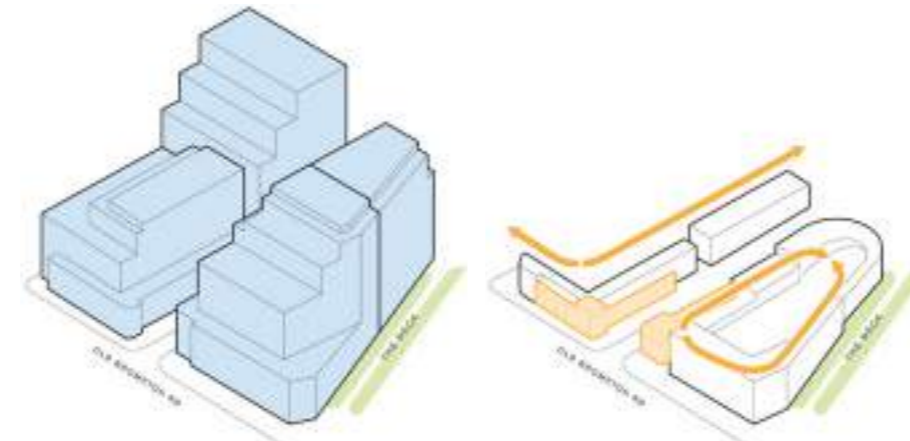

Maximum envelope defined by the Parameter Plans

Partial retention & extension of street

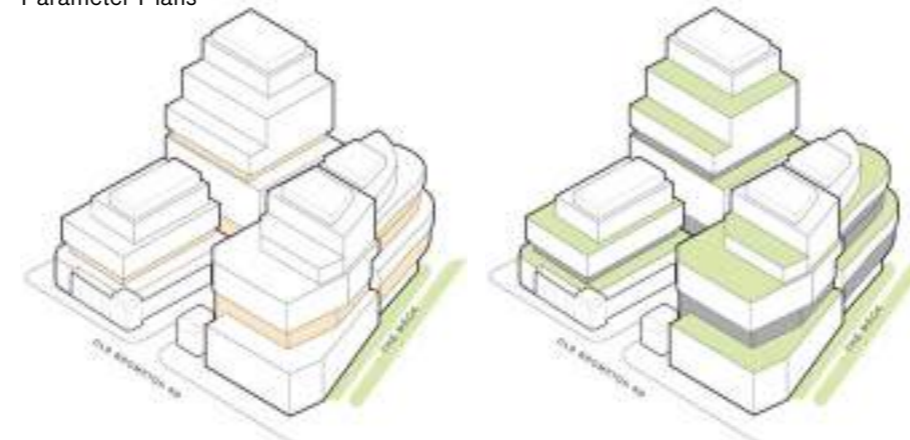

Stepping and layering

Landscaped terraces

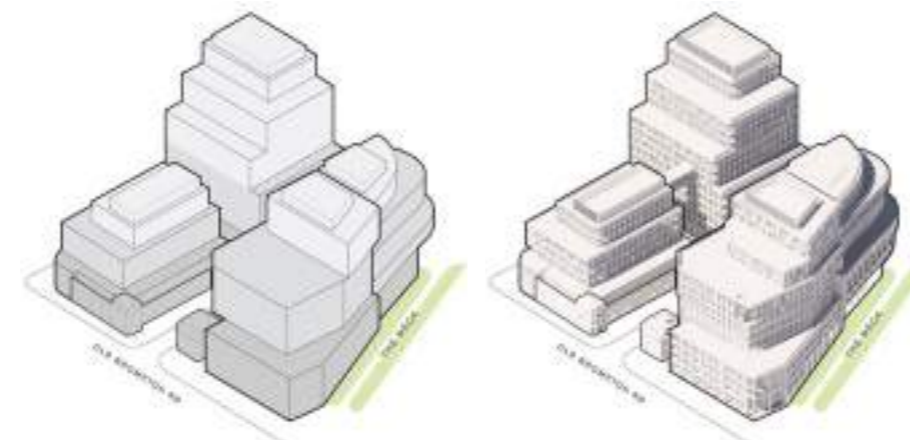

A family of buildings

Illustrative design response

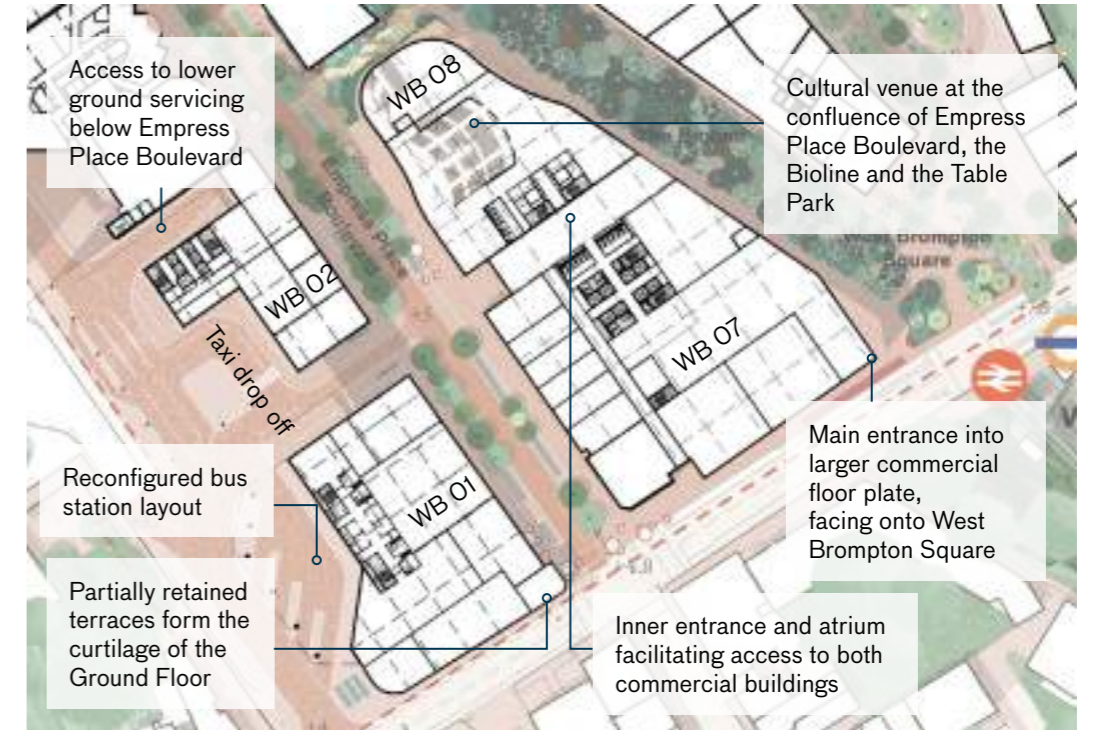

Illustrative Ground Floor plan - mixed-use

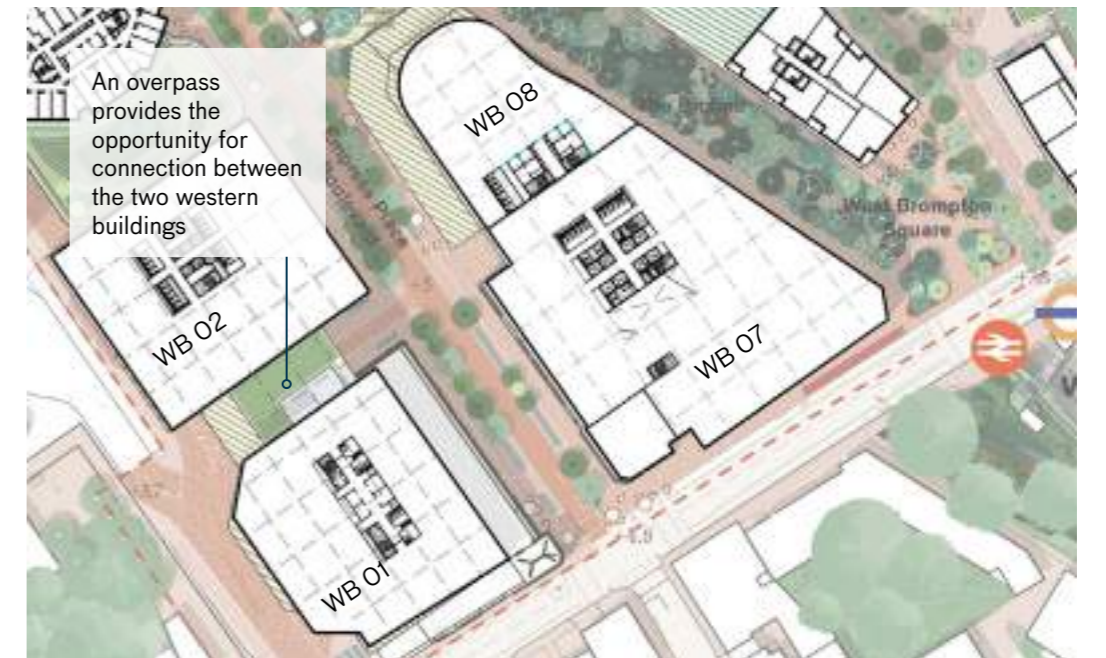

Illustrative typical Upper Floor plan - workspace use



# 6.7 Empress Place | Built Form

Workspace cluster | The Table Edge

## Workspace cluster

Existing terraced buildings form a well-defined active and characterful edge to the boulevard. The reconfigured single-storey mansard roof helps mediate the scale between existing and new buildings.

The key principles that characterise the Workplace cluster are described in the Design Code. These are demonstrated in the illustrative proposal, including:

1 Exploring partial retention

The design prioritises the retention of existing buildings or façades, incorporating them into the new proposals.

2 Creating active frontages

Active frontages provide interaction between internal and external spaces.

3 Integrating existing and proposed volumes

The volume of the existing building is legible in the overall massing composition. A reconfigured mansard roof provides a transition between new and existing fabric.

4 Creating a family of buildings

The family of workspace buildings have a similar approach to detailing and materials.

► Refer to Design Code / Empress Place / Building typologies / Large-footprint (EC.PA.C).

## Illustrative design response



Eye-level view showing the integration of existing and new façades along Empress Place



View of shared roof terrace with potential public access



Materials that correspond to the existing fabric in terms of tonality



## 6.7 Empress Place | Built Form

Workspace cluster | The Table Edge

### Workspace cluster

The key principles that characterise the Workplace cluster are described in the Design Code. These are demonstrated in the illustrative proposal, including:

**1** Creating a legible base

A legible base is created with a horizontal datum established by the scale of the existing buildings on Empress Place is reinforced across the commercial cluster.

**2** Creating intermediate layering

A series of landscape terraces create a sense of layering and break down the massing.

**3** Using materials showcasing innovation

Low carbon structures showcasing a sustainable approach to construction such as using mass timber.

► Refer to Design Code / Empress Place / Building typologies / Large-footprint (EC, P.A.C).

### Illustrative design response



Eye-level view of the workspace cluster along Lillie Road looking into West Brompton Square



Lillie Road frontages are activated with retail, food and beverage and commercial space

A central square framed with a variety of planting

A segregated cycle lane ensures a safe connection for cyclists to the wider active travel network

Pavement widening caters for the anticipated increase in footfall and enhancing safety and wellbeing

Eye-level view showing widening along Lillie Road edge





## 6.7 Empress Place | Built Form

Workspace cluster | The Table Edge

### Cultural venue

Empress Place has the potential to accommodate a bespoke, multifunctional, cultural destination that builds upon the legacy of performance at Earls Court.

A transparent double height Ground Floor lobby forms the main entrance to the cultural space facing both the Table Park and Empress Place Boulevard. The transparency provides a sense of continuity with the public realm. The level change between the park and boulevard accommodates raked seating surrounding the performance area.

The space has been capacity tested to fit an auditorium of up to approximately 600 seats, but could also be configured for a range of different spaces and performances. It spans multiple levels, has three frontages and straddles LBHF and RBKC.

► Refer to *Design and Access Statement Volume 1: Outline Component / The Illustrative Masterplan / Sitewide proposals / A cultural destination (EC.PA.08)*.

### Illustrative design response



Eye-level view of a flexible presentation space visually connecting with the public realm



Eye-level view of the cultural space configured to fit up to a 600-seat closed auditorium



Eye-level view of the cultural venue at Empress Place



# 6.7 Empress Place | Built Form

Workspace cluster | The Table Edge

## The Table Edge

Plot Code: WBO9, WB10  
Typology: Table Edge

The Table Edge will have a unique architectural character and support retail, leisure, café and cultural uses to animate Empress Place Boulevard with active frontage and spill-out seating.

The key principles that characterise the Table Edge are described in the Design Code. These are demonstrated in the illustrative proposal, including:

- Extending the Table Edge to clearly frame the boulevard.
  - Animating the public realm through active frontages.
  - Expressing a vertical rhythm and celebrating a unique building typology.
  - Facilitating a visual connection with the Table Park above.
- ▶ Refer to Design Code / Empress Place / Building typologies / Table Edge (EC.PA.C).
- ▶ Refer to Design & Access Statement Volume 1: Outline Component / Spatial Strategies / Landscape / Play - Scenario testing (EC.PA.08).

## Illustrative design response

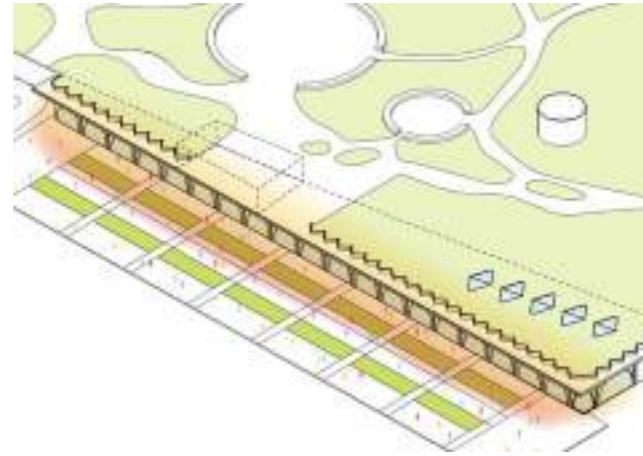

Continuous active frontage with potential skylight from above

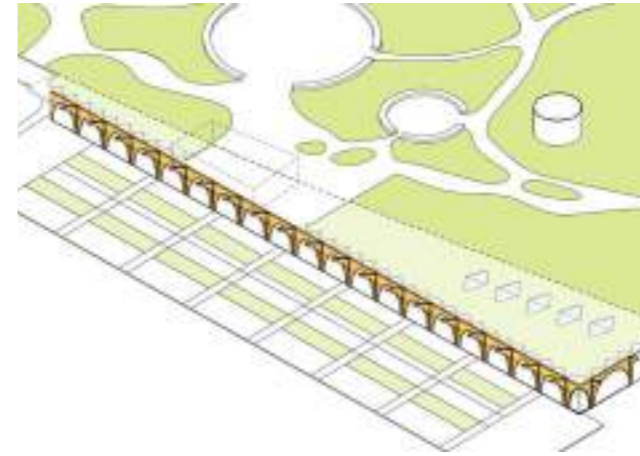

Potential of using expressive low-carbon timber structure



Eye-level view of the Table Edge showing spill-out spaces along the boulevard



Small scale units occupy the level change and open onto the boulevard



Active play can be introduced to address the level change



# Aisgill Gardens





# 6.8 Aisgill Gardens | Overview

Aisgill Gardens is a community green that includes amenities for all ages and connects to the neighbouring Gibbs Green and West Kensington Estates. It plays an important role as the primary arrival point from the west and as a destination play space.

This section illustrates how the Character Area has been developed alongside the Control Documents. Key principles that characterise Aisgill Gardens are set out on the image on the right.

▶ Refer to Design Code / Aisgill Gardens (EC.PA.C).

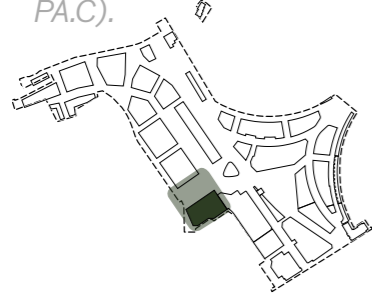

Location of West Brompton Character Area

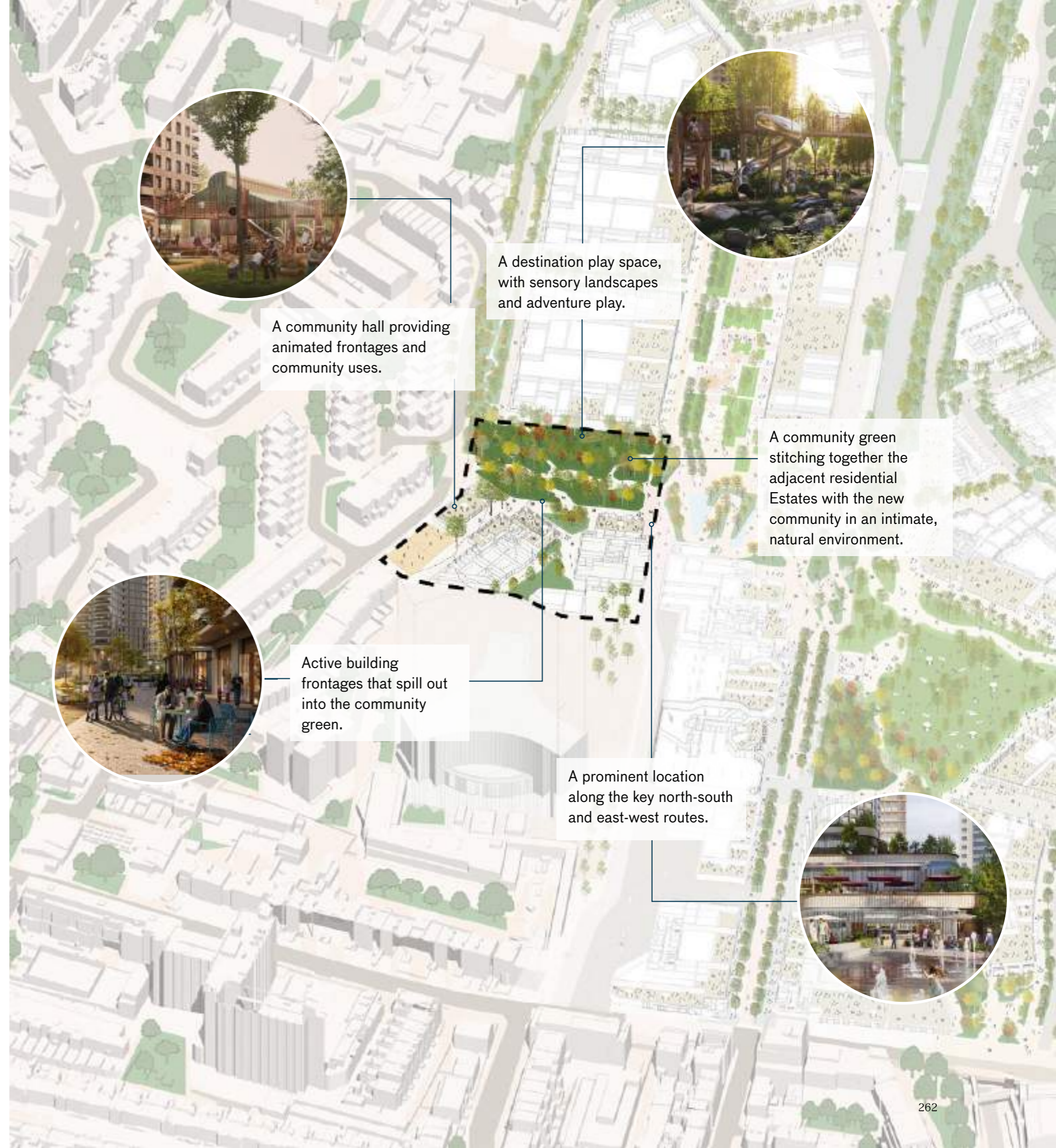

A community hall providing animated frontages and community uses.



A destination play space, with sensory landscapes and adventure play.



Active building frontages that spill out into the community green.

A community green stitching together the adjacent residential Estates with the new community in an intimate, natural environment.

A prominent location along the key north-south and east-west routes.





## 6.8 Aisgill Gardens | Public Realm

The design of the public realm of Aisgill Gardens is a generous, inclusive and community-oriented green open space that brings residents together and welcomes people into the Site.

The key principles that characterise Aisgill Gardens are described in the Design Code. These are demonstrated in the illustrative proposal, including:

- A nature-based, generous and open oasis at the confluence of existing and new neighbourhoods.
- Accessible and multi-generational spaces for gathering, play and daily activities.
- Community, health and wellbeing uses fronting onto the open space, providing additional access to social infrastructure.
- Uses established through engagement, including: unplanned trails, a picnic patch, adventure wilderness, and a community Pavilion\*.
- Planting that amplifies biodiversity and ecology, bringing people and nature together.
- A distinctive identity that forms part of the wider Exhibition Gardens approach.

\*Delivery of the community hall and extended multi-use games area (MUGA) are subject to land agreements with third parties.

▶ Refer to Design Code / Aisgill Gardens / Landscape (EC.PA.C).

▶ Refer to Design Code / Sitewide / Landscape (EC.PA.C).

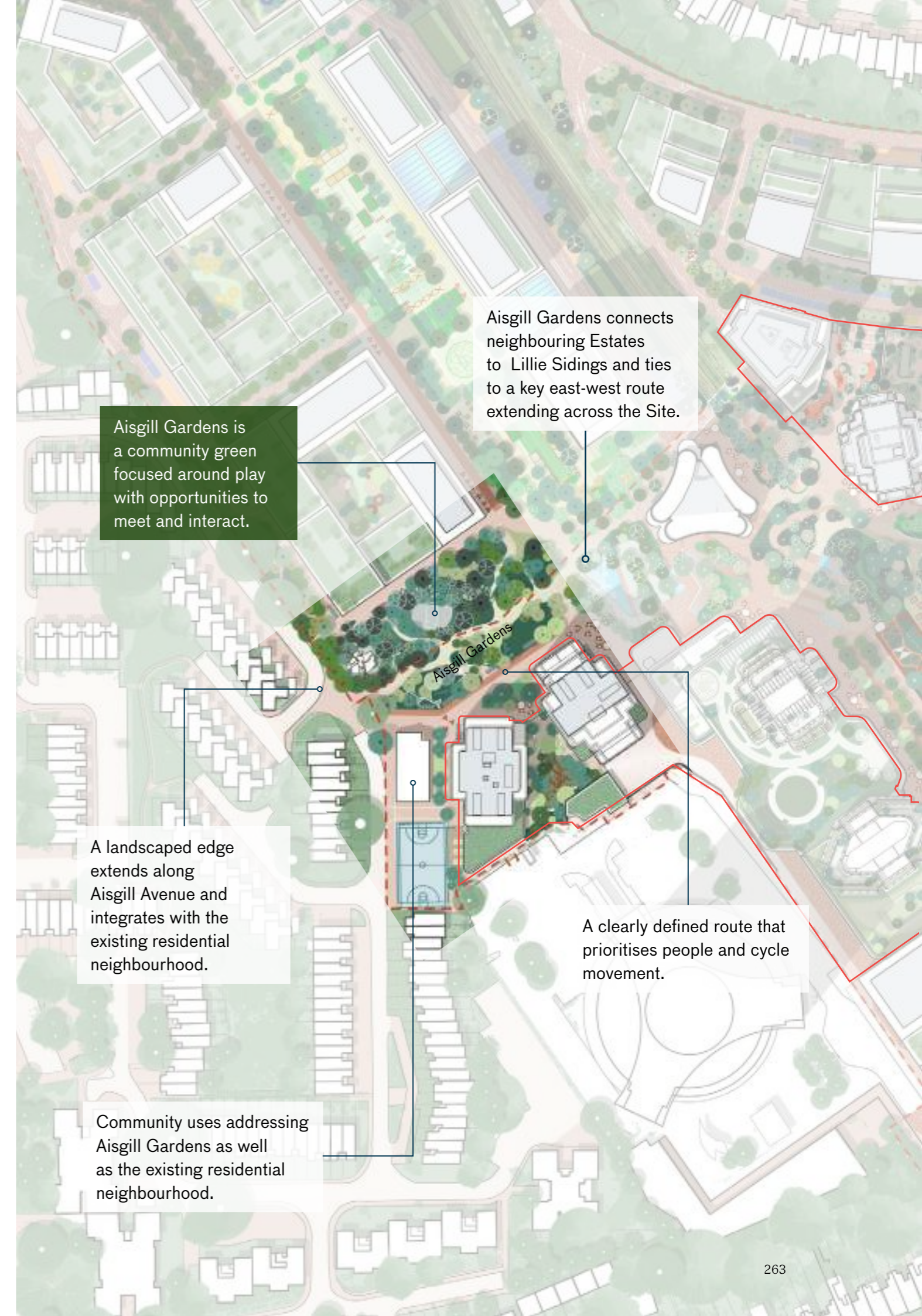

# 6.8 Aisgill Gardens | Public Realm

## Designing for inclusivity

Designed with the Public Realm Inclusivity Panel (PRIP), the zoning and programming of the landscape focuses on creating a place that feels safe, inclusive and accessible for all.

The PRIP has worked with the Design Team to inform the illustrative proposals. Aisgill Gardens will offer a variety of experiences and a diverse array of activities for different user groups and ages. The key design principles identified by the PRIP are outlined to the right.

- ▶ Refer to Design Code / Sitewide / Landscape / Inclusivity and Movement (EC.PA.C).
- ▶ Refer to Design and Access Statement Volume 1: Outline Component / Spatial Strategies / Landscape / Planting / The community orchard at Aisgill Gardens (EC.PA.08).

## Key PRIP Design Principles

	A range of spaces and experiences: both active and quiet spaces		Allowance for risky play
	People watching: places to sit and observe people or children playing		Well-lit routes that work in all weather
	Cycle parking close to activities, not tucked away		Variety of spaces and activities: play spaces, and quiet spaces
	Seating along routes for people to sit and rest.		A need for a protected shelter so that it is usable all year round.
	Creating sensory activities		Somewhere for dog walkers



Illustrative concept for Aisgill Garden

# 6.8 Aisgill Gardens | Public Realm

## Aisgill Gardens

The key principles that characterise Aisgill Gardens are described in the Design Code. These are demonstrated in the illustrative proposal, including:

- 1** Creating a pedestrian-friendly environment  
Pedestrian and cycle routes are located at the edges of Aisgill Gardens.
- 2** Prioritising community uses  
Community uses are located on the Ground Floor, spilling out into the public realm and activating the garden.
- 3** Creating a destination play space  
A variety of play spaces create a welcoming and varied public realm designed around inclusivity.
- 4** Designing intimate spaces  
Along with play spaces, the layout of the community green facilitates a sense of enclosure and intimacy.

► Refer to Design Code / Aisgill Gardens / Landscape / Aisgill Gardens (EC.PA.C).



Key plan

## Illustrative design response



Eye-level view showing community uses and landscaping at Aisgill Gardens

# 6.8 Aisgill Gardens | Public Realm

## Dissolving the red line boundary

Through a sensitive edge design and the introduction of communal uses, Aisgill Gardens becomes a thriving community amenity for existing and new residents, effectively dissolving the red line boundary.

A variety of approaches to this boundary condition have been explored, all of which aim to stitch Aisgill Gardens in with the existing neighbourhood. These options include:

- Seated edge
- Graded low wall edge
- Interactive play wall

► Refer to Design Code / Aisgill Gardens / Landscape / Aisgill Gardens (EC.PA.C).



Key plan

## Illustrative design testing



Edge condition study 01 - showing the potential boundary condition of Aisgill Gardens with a seated edge

### Study 01 - Seated Edge

A seated edge provides a fluid threshold that interacts both with the area towards Gibbs Green and Aisgill Gardens, accommodating accessible seating for people watching and gathering.



Edge condition study 02 - showing the potential boundary condition of Aisgill Gardens with a graded low wall

### Study 02 - Graded Low Wall Edge

A graded wall fosters interaction without favouring one space over the other and can be designed to seamlessly integrate with planted zones.

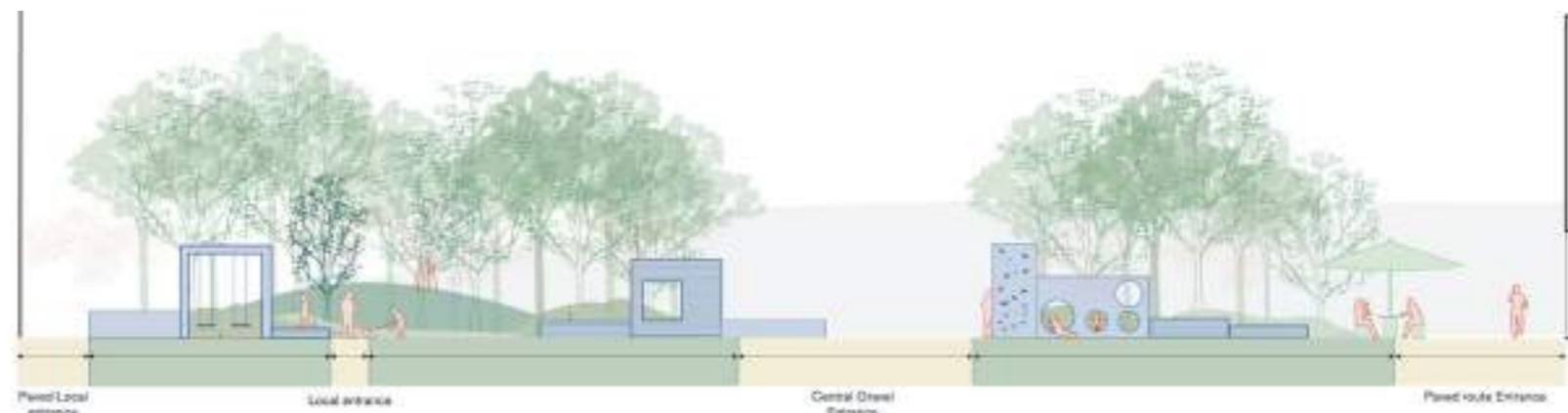

Edge condition study 03 - showing the potential boundary condition of Aisgill Gardens with an interactive play wall

### Study 03 - Interactive Play Wall

Incorporating the concept of a graded wall and integrating play elements can provide additional activities and enhance the appeal of both Aisgill Gardens and Gibbs Green.



# 6.8 Aisgill Gardens | Built Form

Aisgill Gardens is framed by Plots to the north and south, with a Pavilion marking the western edge of the Site. Buildings increase in scale from the neighbouring estates towards the centre of the development, while ground-floor community uses activate the edges of the community green.

The Illustrative Masterplan responds to key built form principles outlined in the Control Documents, including:

- Building frontages that frame and activate the green.
- Providing access to community and cultural uses, a café, as well as homes.
- Providing a Pavilion (community hall) marking the western edge of the community green.

Aisgill Gardens is comprised of the following built form typologies:

- Perimeter block façade addressing Aisgill Gardens
- Pavilion
- Detailed Components (refer to Detailed Component DAS)

- ▶ Refer to Design Code / Aisgill Gardens / Built form (EC.PA.C).
- ▶ Refer to Design Code / Sitewide / Built form (EC.PA.C).
- ▶ Refer to Development Specification (EC.PA.A).

The below plans outline the land use emphasis of the Illustrative Masterplan within the Character Area. Full detail of the permitted land uses are described in the Development Specification.

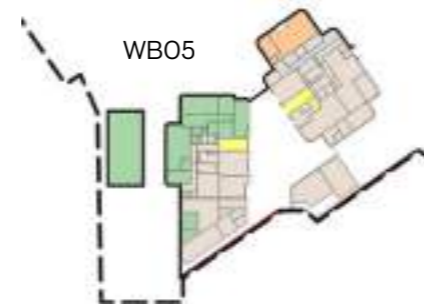

Illustrative Ground Floor land use plan

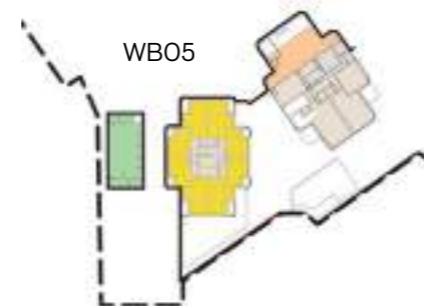

Illustrative Typical Upper Floor land use plan

<span style="display:inline-block; width:10px; height:10px; background-color:yellow; border:1px solid black;"></span> Residential	<span style="display:inline-block; width:10px; height:10px; background-color:lightgreen; border:1px solid black;"></span> Community
<span style="display:inline-block; width:10px; height:10px; background-color:orange; border:1px solid black;"></span> Residential Amenity	<span style="display:inline-block; width:10px; height:10px; background-color:lightblue; border:1px solid black;"></span> Flexible Commercial/Culture
<span style="display:inline-block; width:10px; height:10px; background-color:lightgrey; border:1px solid black;"></span> Residential BOH & Cores	

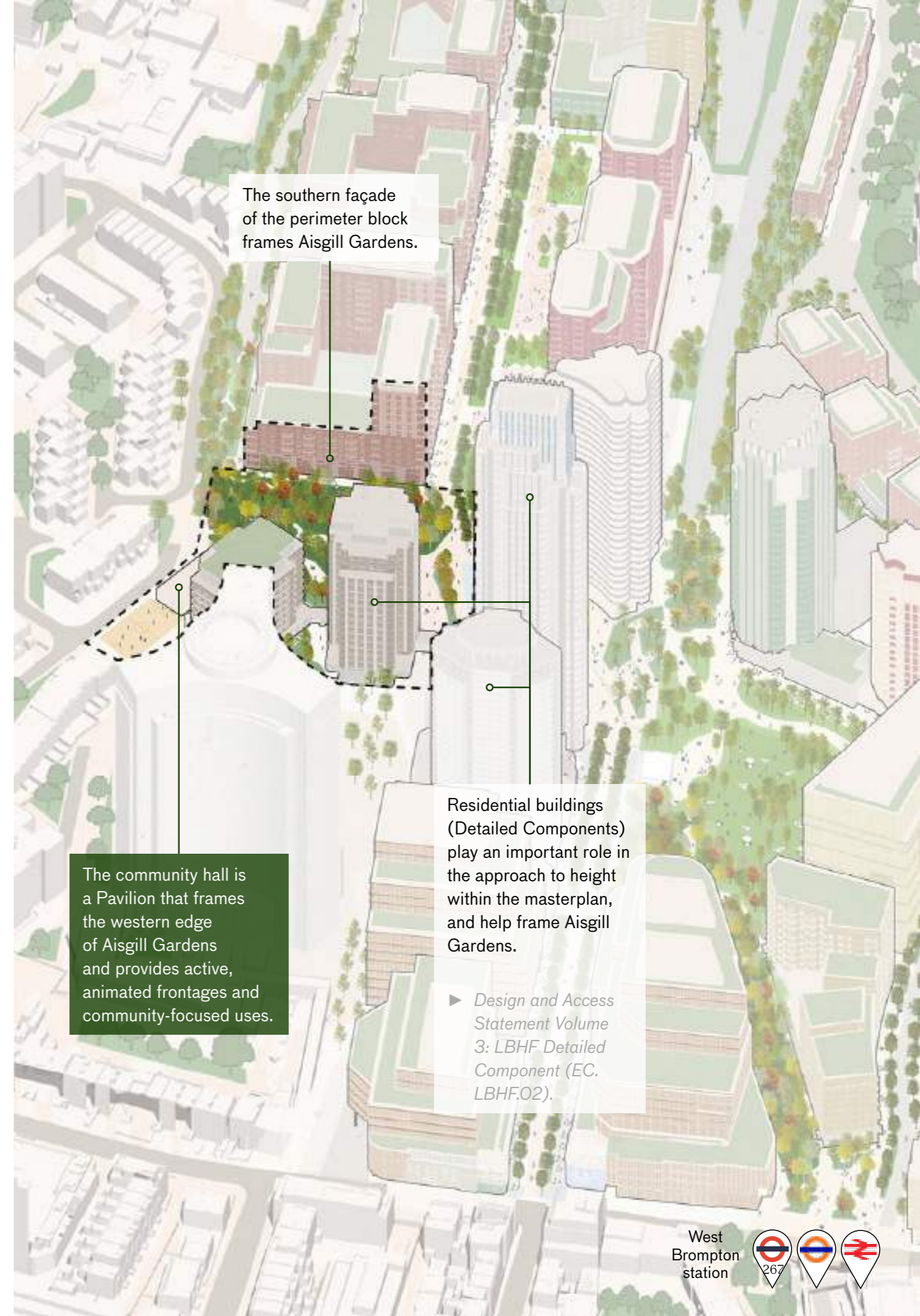

▶ Design and Access Statement Volume 3: LBHF Detailed Component (EC.LBHF.02).



## 6.8 Aisgill Gardens | Built Form

Perimeter block façade | Community Hall

### Perimeter block façade addressing Aisgill Gardens

The key principles that characterise the Perimeter block façade are described in the Design Code. These are demonstrated in the illustrative proposal, including:

**1** Using rhythm and articulation

Individual building expression through subtle changes in tone, composition and materials break down the scale of massing.

**2** Emphasising prominent corners

Expression of key corners through articulation of the top of buildings.

**3** Creating a community ecosystem

Access to community, health and wellbeing use with spill-out space at Ground Floor level that activates the open space.

▶ Refer to Design Code / Sitewide / Built form / Frontages & façades (EC.PA.C).

▶ Refer to Design Code / Aisgill Gardens / Built form / Perimeter block (EC.PA.C).



Key plan

### Illustrative design response



Eye-level view showing the perimeter block façades creating a backdrop to Aisgill Gardens

# 6.8 Aisgill Gardens | Built Form

Perimeter block façade | Community Hall

## Community hall

Plot Code: WB05  
Typology: Pavilion

The community hall frames the western edge of the masterplan and provides active and animated frontages through community focused uses.

The proposal forms one possible option for the community hall. The key principles that characterise the community hall are described in the Design Code. These are demonstrated in the illustrative proposal, including:

- A community facility that has an adaptable and flexible design catering for an array of uses.
- Creating a building that is a backdrop to Aisgill Gardens.
- Providing a connection with the public realm for community events.

- ▶ Refer to Design Code / Aisgill Gardens / Built form / Pavilion (I) (EC.PA.C).
- ▶ Refer to Design and Access Statement Volume 3: LBHF Detailed Component (EC.LBHF.02).

## Illustrative design response



Illustrative location plan of the potential community hall



Illustrative precedent of a weather-proof permeable structure



Illustrative view of internal community space



Connection with Aisgill Avenue and proposed Yard space



Adaptable design to enable private functions and performances

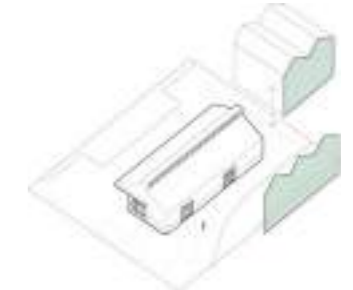

Height and pitched roof echoes scale and profile of homes on Aisgill Avenue



Adaptable design to allow for permeability and extension into the public realm for community events



Articulated base and a sculpted roof



The community hall is surrounded by landscape, seating and spill out areas

# 6.8 Aisgill Gardens | Built Form

Perimeter block façade | Community Hall

## Community Hall

The key principles that characterise the community hall are described in the Design Code. These are demonstrated in the illustrative proposal, including:

**1** Integrating with landscape design

The building acts as a backdrop to the landscape and is designed to integrate with the community green.

**2** Creating visually permeable and welcoming frontages

The building is designed to allow for permeability and extension into the public realm.

**3** Referencing the Detailed Component design

The building responds to the massing, articulation and architectural expression of the Detailed Component.

▶ Refer to Design and Access Statement Volume 3: LBHF Detailed Component (EC.LBHF.02).

## Illustrative design response



Eye-level view showing the Illustrative Design for the community Pavilion at Aisgill Gardens



Large format materials with decorative top and durable base



Art Deco and industrial character references



Timber structure



Tonal variation within façade



## 6.8 Aisgill Gardens | Built Form

Perimeter block façade | Community Hall

### Aisgill Avenue MUGA

Located behind the community hall, the Aisgill Avenue multi-use games area (MUGA) is an invaluable community asset, serving as an amenity for both existing and new residents.

The existing sports area on Aisgill Avenue lies to the west of the proposed Site boundary. Its irregular triangular shape has meant the court is underutilised by the community. The illustrative design proposes a new, purpose-built rectangular sports area\*, removing the brick wall that segregates the Site to create a usable court for all.

\*This proposal relies on a land-swap with LBHF, which has been discussed with the local authority.



Existing triangular sports area and brick wall

### Illustrative design response



Eye-level view showing the potential for a new purpose built rectangular sports area along Aisgill Avenue



A welcoming and accessible place for people to enjoy and connect with nature.

Buildings step down to the edges and frame the green with homes.

A generous community-focused space, offering a shared place where residents come together.

A welcoming space creating an accessible route all the way to Earl's Court station.

Play for all ages is integral to the landscape design.

A playful landscape with varied planting, colours and textures.

# Lillie Sidings





# 6.9 Lillie Sidings | Overview

Lillie Sidings celebrates the Site's industrial heritage with a new mixed-use destination square, framed by the reimagined Train Shed, hosting dining, events and cultural activities.

This section illustrates how the Character Area has been developed alongside the Control Documents. Key principles that characterise Lillie Sidings are set out on the image on the right.

► Refer to Design Code / Lillie Sidings (EC.PA.C).

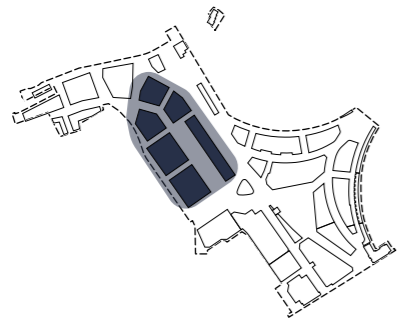

Location of West Brompton Character Area



West Kensington station



A vehicle-free destination square at the centre connected by lanes, walks and the boulevard.



Creating a mix of housing typologies, catering for multi-generational living across multiple tenures.

Culture, cafés, restaurants and leisure destinations spill out onto the square bringing the public realm to life.



Stitching in and stepping down in scale to meet existing streets and the adjacent Estates.



The creative reuse of the historic Lillie Bridge Depot (The Train Shed) with a cultural destination at Ground Floor.





# 6.9 Lillie Sidings | Public Realm

The public realm is defined by a vehicle-free destination square that contains the key north-south route. The boulevard, surrounding lanes and walks stitch into the wider community with a quieter residential character.

Key spaces and routes are outlined in the Control Documents, including:

### Spaces and routes

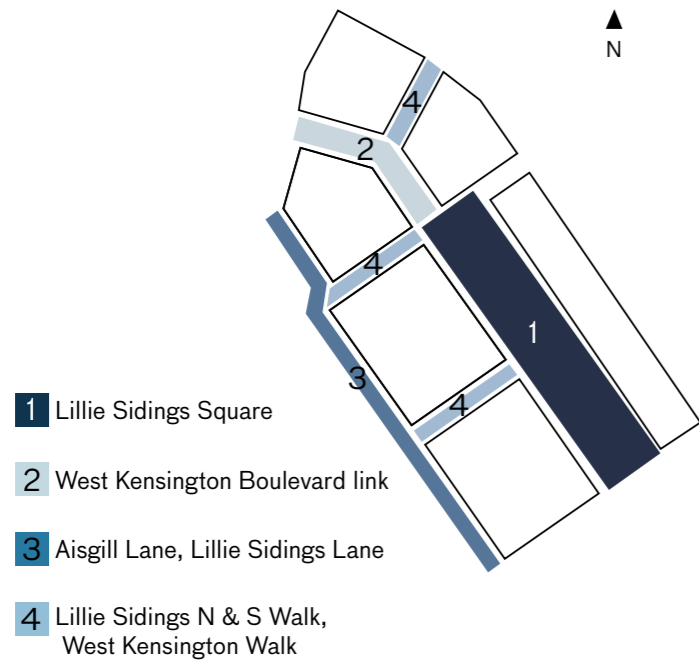

### Access and movement

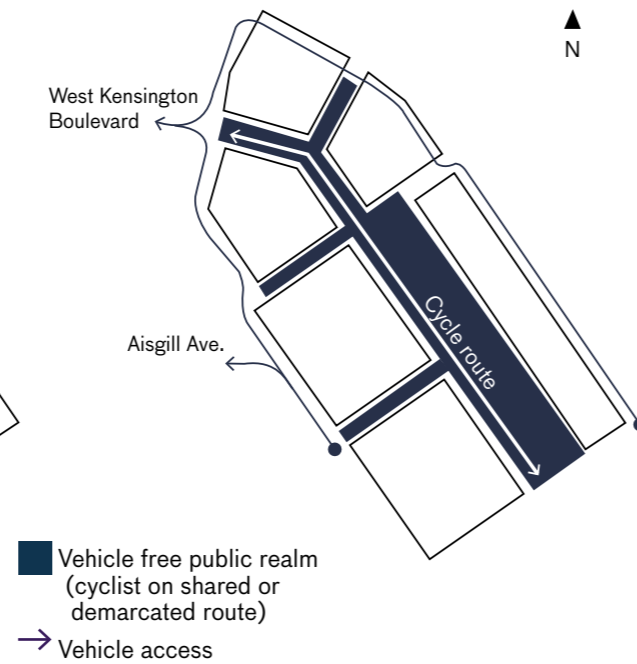

- ▶ Refer to Design Code / Lillie Sidings / Landscape (EC.PA.C).
- ▶ Refer to Design Code / Sitewide / Landscape (EC.PA.C).

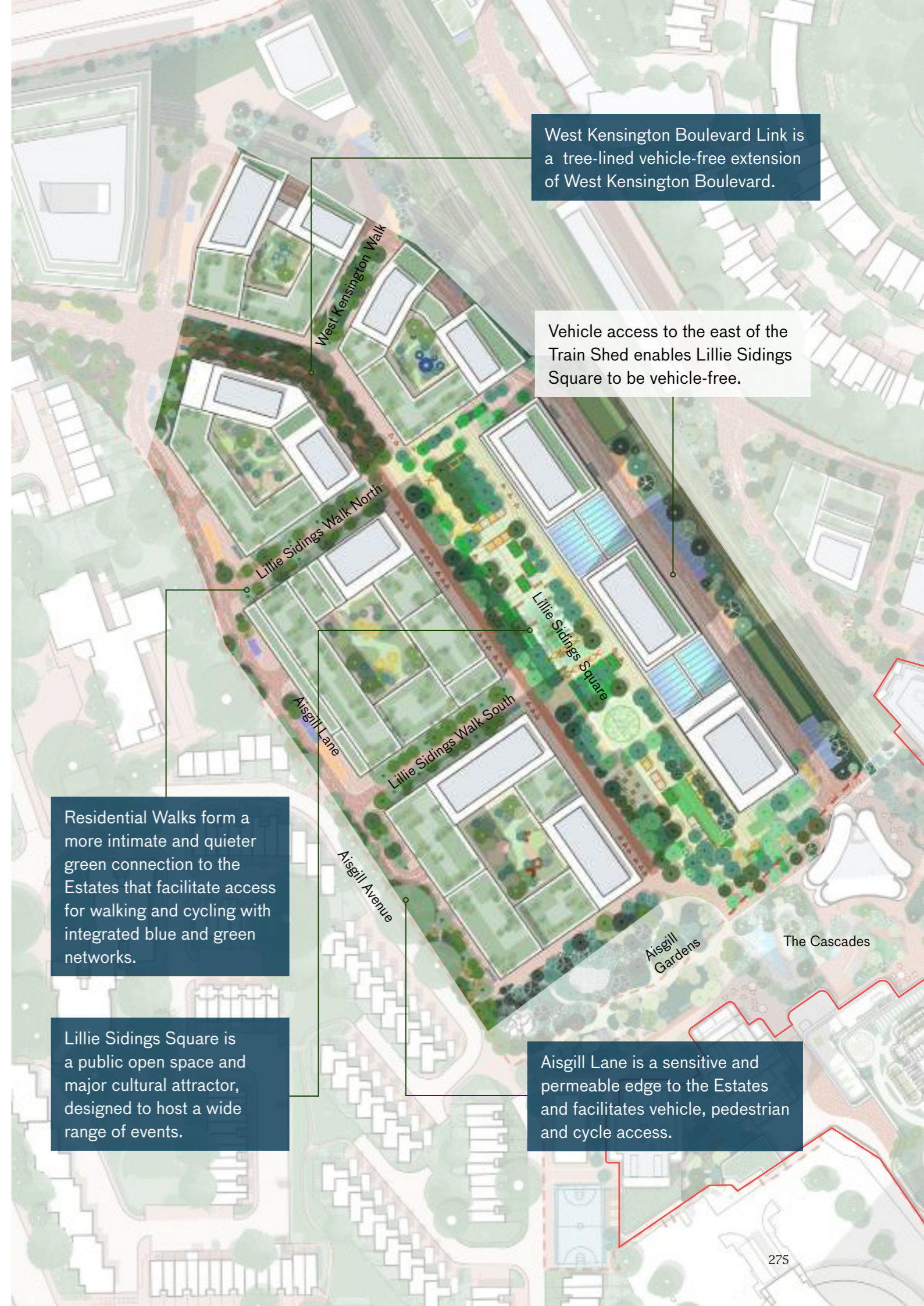



# 6.9 Lillie Sidings | Public Realm

Square | Boulevard Link | Lanes | Walks

## Lillie Sidings Square

The destination square celebrates the Site's industrial heritage while incorporating flexible space for events and landscape which supports biodiversity.

The key principles that characterise Lillie Sidings Square are described in the Design Code. These are demonstrated in the illustrative proposal, including:

- Providing a primary location within the proposal for cultural programming and events.
- Incorporating a generously landscaped forecourt with a distinctly industrial character.
- Using the re-purposed Train Shed as a backdrop, framing the square and integrating the historic setting to the public open space.

▶ Refer to Design Code / Lillie Sidings / Landscape / Lillie Sidings Square (EC.PA.C).

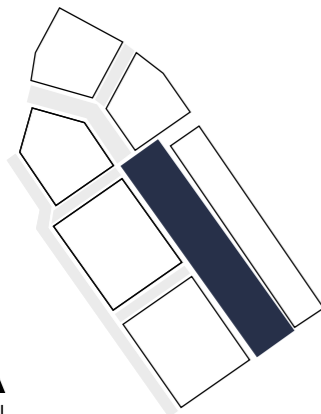

## Illustrative design response



Illustrative plan of Lillie Sidings Square

Carefully considered retention and extension of Lillie Sidings Train Shed will enhance the industrial character of this area.

A cultural destination/venue is located in the re-purposed Train Shed.

Spill out space activates the edge of the Train Shed.

Potential reuse of existing railway assets celebrates the Site's industrial heritage.

A line of tree planting reinforces the key north-south route.

An area of hardscape allows for events to take place within the destination square.

Post-industrial remediation gardens provide a diverse and connected green network.



Precedents showing landscape design incorporating industrial heritage



Pop-up events



Coal Drops Yard at King's Cross showing a market event

# 6.9 Lillie Sidings | Public Realm

Square | Boulevard Link | Lanes | Walks

## Lillie Sidings Square

The key principles that characterise Lillie Sidings Square are described in the Design Code. These are demonstrated in the illustrative proposal, including:

- 1** Creating a destination square  
Creating a destination through integrating a mix of uses including the potential for a cultural venue.
- 2** Celebrate industrial heritage  
Reuse of industrial materials in the public realm establishes a distinctive industrial character to the landscape.
- 3** Providing a north-south route  
Movement routes are framed by trees, providing legibility for the north-south route.
- 4** Encouraging spill-out  
Cultural uses within the repurposed Train Shed spill out into the square.
- 5** Planning for SuDS features  
Sustainable rain gardens and storm water management are integrated into the landscape design.

► Refer to Design Code / Lillie Sidings / Landscape / Lillie Sidings Square (EC.PA.C).

## Illustrative design response



Eye-level view showing activation and cultural uses spilling onto Lillie Sidings Square



# 6.9 Lillie Sidings | Public Realm

Square | Boulevard Link | Lanes | Walks

## West Kensington Boulevard Link

West Kensington Boulevard Link reinforces the north-south route from Lillie Sidings Square toward West Kensington station with an active tree-lined pedestrian and cycle route.

The key principles that characterise West Kensington Boulevard Link are described in the Design Code. These are demonstrated in the illustrative proposal, including:

- Providing a generous spill-out space for Ground Floor uses on the eastern side of the route.
- Extending the active frontages surrounding the destination square along the link.
- Creating trees and planting beds along the boulevard to help frame the street and create a biodiverse and climate-resilient environment.

▶ Refer to Design Code / Lillie Sidings / Landscape / West Kensington Boulevard Link (EC.PA.C).

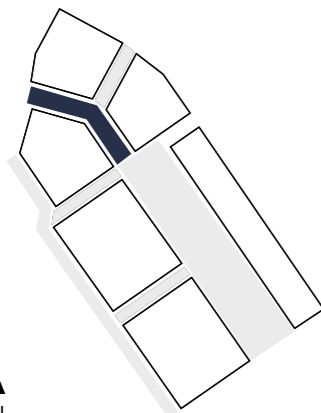

## Illustrative design response

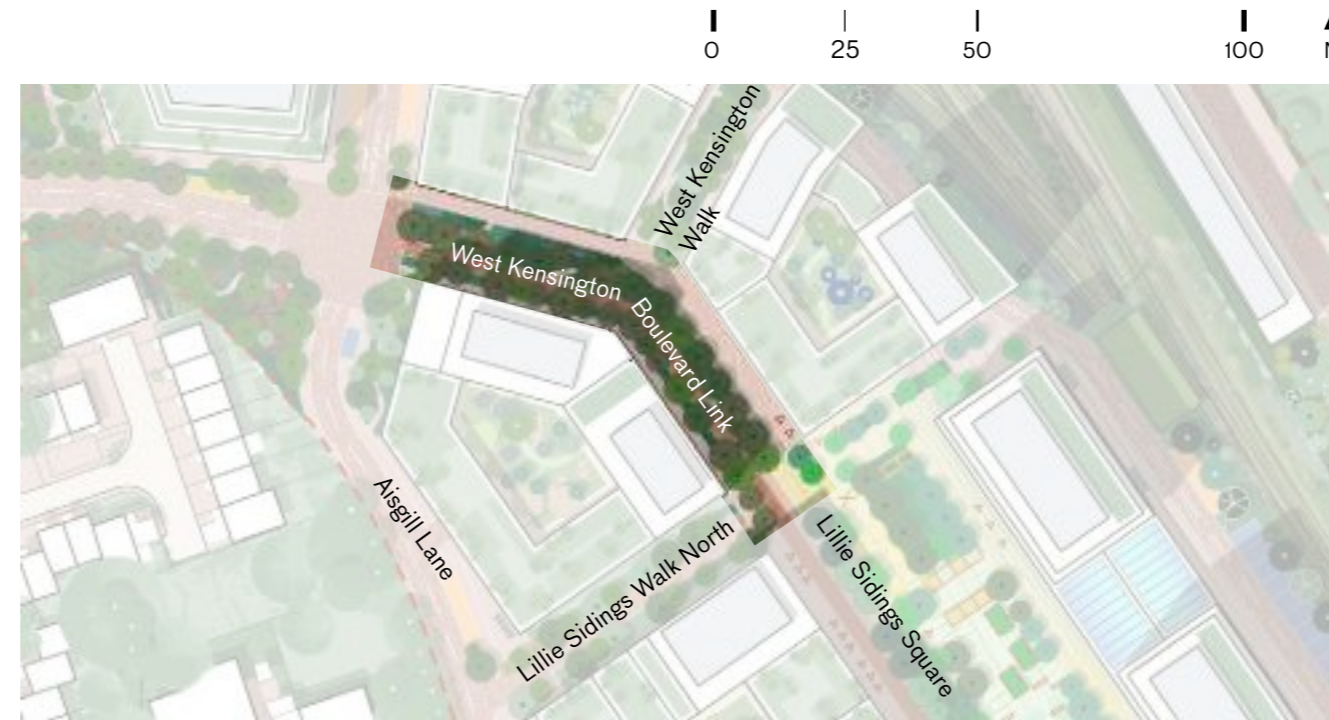

Illustrative plan of West Kensington Boulevard Link



Illustrative street section

Tree-lined boulevard

Vehicle-free with demarcated cycle route

Spill-out zone



Illustrative precedents of the tree-lined boulevard



# 6.9 Lillie Sidings | Public Realm

Square | Boulevard Link | Lanes | Walks

## Aisgill Lane

Aisgill Lane provides an important linear landscape that stitches the Proposed Development in with the neighbouring Estate. The lane integrates access to the new residential blocks and features generous planting and incidental play.

The key principles that characterise Aisgill Lane are described in the Design Code. These are demonstrated in the illustrative proposal, including:

- Creating an integrated edge between the proposal and neighbouring Estate.
- Accommodating Sustainable Drainage Systems (SuDS) and green infrastructure, introducing biodiverse planting and space for play.
- Exploring an increase of permeability by adding breaks or replacing the existing wall with a linear landscape.
- Maximising permeability and creating a visual connection across the Site boundary.

▶ Refer to Design Code / Lillie Sidings / Spaces / Aisgill Lane (EC.PA.C).

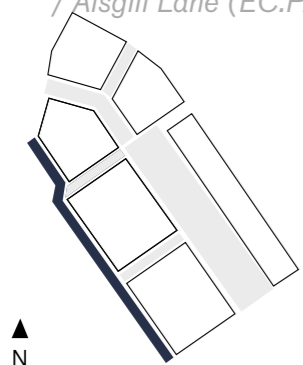

## Illustrative design response

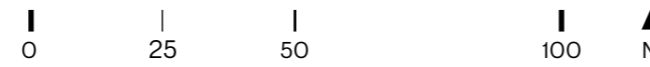

Illustrative plan of Aisgill Lane



Eye-level view of front doors onto Aisgill Lane

Low level planting denotes a separation without obstructing visual connections.

Existing and new trees define the Aisgill Avenue edge.

Play and seating incorporated into the landscaped edge creates a shared amenity space where new and existing neighbours can meet.

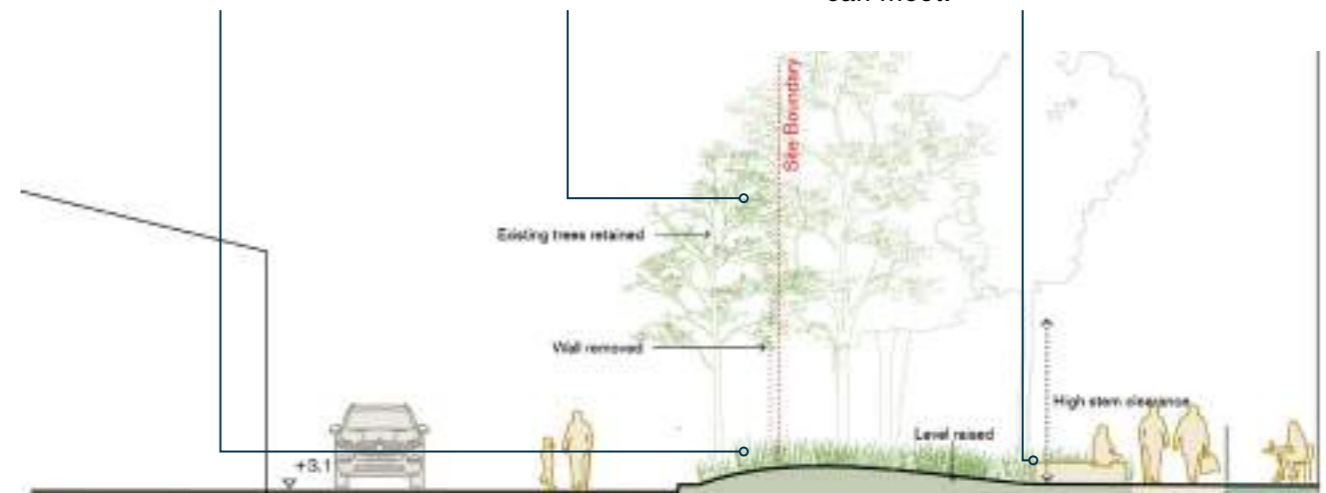

Illustrative section of Aisgill Lane



# 6.9 Lillie Sidings | Public Realm

Square | Boulevard Link | Lanes | Walks

## Lillie Sidings Walks (North and South) and West Kensington Walk

The walks provide intimate, pedestrian priority public realm to stitch together adjacent squares and boulevards with the residential character of the existing neighbourhood.

Planted walks open up the Site to the Estates and provide local access for walking and cycling. They have a distinct residential character that is vehicle-free to create a safe environment where children can play and neighbours can meet.

- ▶ Refer to Design Code / Lillie Sidings / Landscape / Lillie Sidings Walks (North & South) (EC.PA.C).
- ▶ Refer to Design Code / Lillie Sidings / Landscape / West Kensington Walk (EC.PA.C).

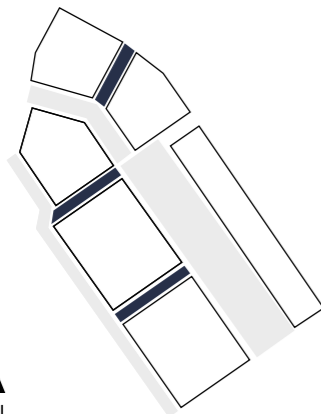

## Illustrative design response

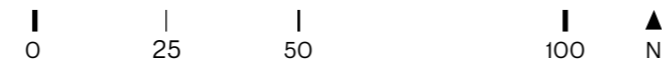

Illustrative plan of Lillie Sidings Walks (North and South) and West Kensington Walk



A residential feel with play in the street



A residential feel with planting and defensible space



Eye-level view showing the residential character of Lillie Sidings Walk South

# 6.9 Lillie Sidings | Built Form

The buildings within Lillie Sidings frame the destination square, gradually stepping down in height from the taller structures along the railway line to the lower buildings at the edge of the adjacent Estate.

The Illustrative Masterplan responds to key built form principles outlined in the Control Documents including:

- Framing the destination square around the repurposed Train Shed.
- Mediating scale between the existing context and the Train Shed building with perimeter blocks.
- Stepping up in height against the railway line above the Train Shed building.
- Creating active Ground Floor frontages that respond to their specific context and place.

Lillie Sidings is comprised of the following built form typologies:

- Perimeter blocks
- Transition blocks
- Common base

- ▶ Refer to Design Code / Lillie Sidings / Built form (EC.PA.C).
- ▶ Refer to Design Code / Sitewide / Built form (EC.PA.C).
- ▶ Refer to Development Specification (EC.PA.A).

The below plans outline the land use emphasis of the Illustrative Masterplan within the Character Area. Full detail of the permitted land uses are described in the Development Specification.

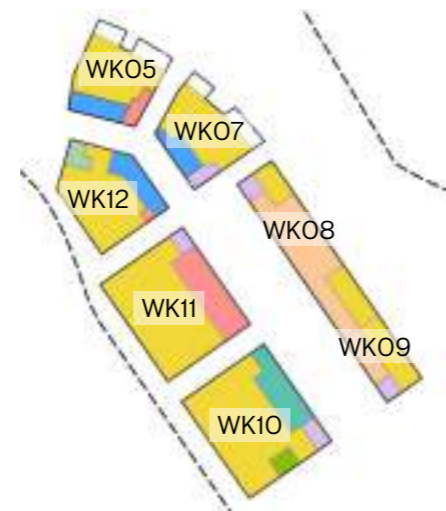

Illustrative Ground Floor land use plan

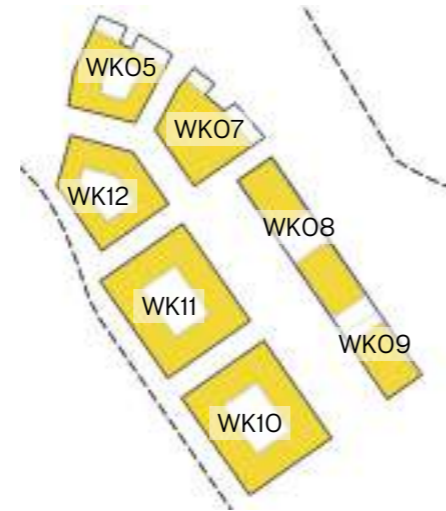

Illustrative Typical Upper Floor land use plan

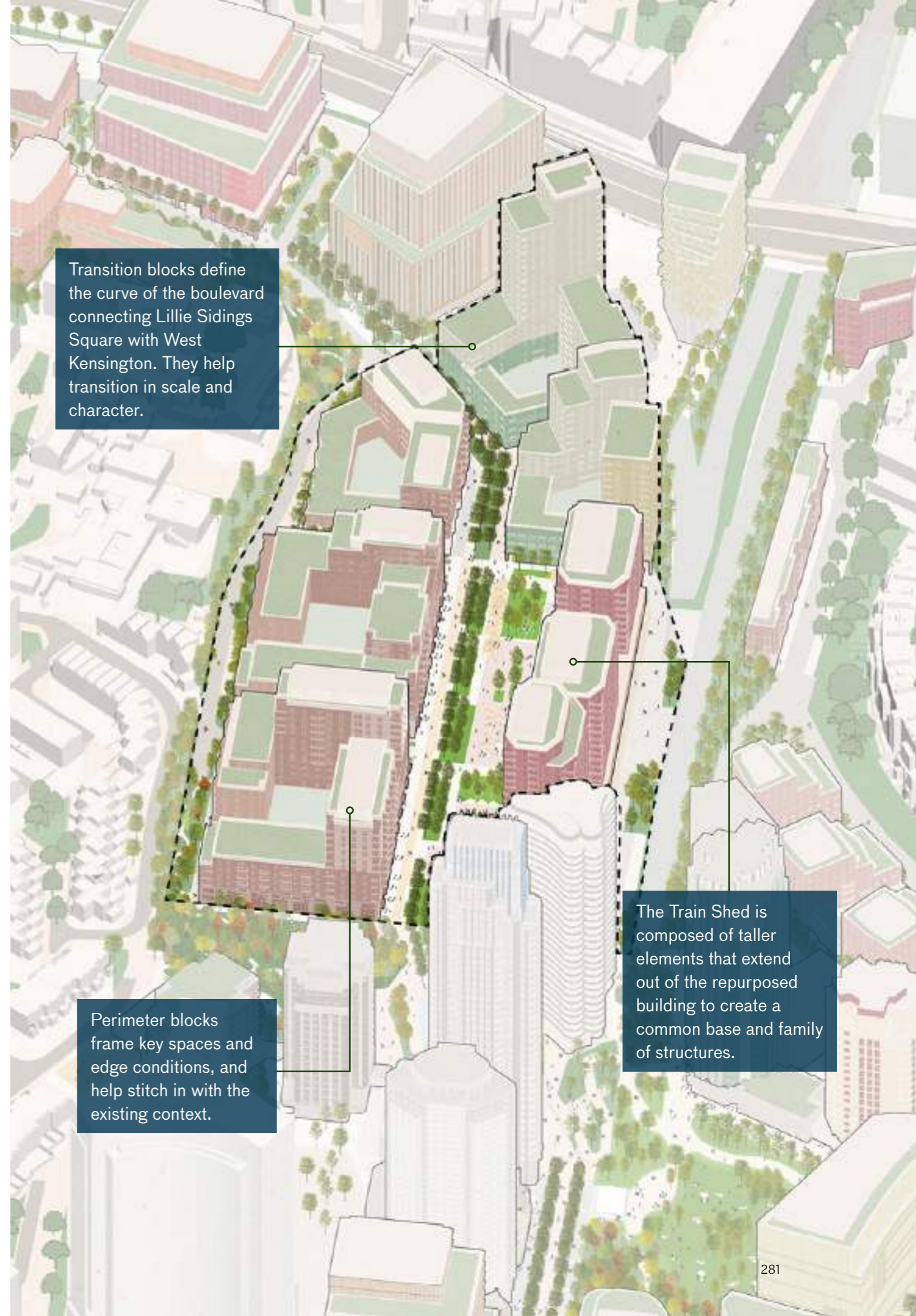
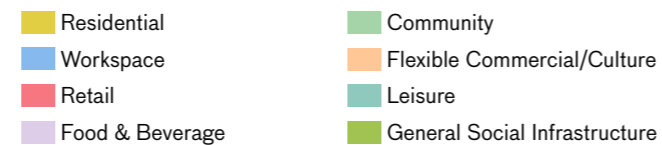

Transition blocks define the curve of the boulevard connecting Lillie Sidings Square with West Kensington. They help transition in scale and character.

The Train Shed is composed of taller elements that extend out of the repurposed building to create a common base and family of structures.

Perimeter blocks frame key spaces and edge conditions, and help stitch in with the existing context.

# 6.9 Lillie Sidings | Built Form

The Train Shed | Perimeter blocks | Transition blocks

## The Train Shed

Plot Code: Wk08, WK09  
Typology: Common base

The Train Shed, within Lillie Bridge Depot, is creatively reimagined, blending the historic fabric with contemporary architecture to create a distinctive expression that responds to the Site's industrial heritage.

The key principles that characterise the Train Shed are described in the Design Code. These are demonstrated in the illustrative proposal, including:

- Creating taller residential components that extend out of the repurposed Train Shed.
- Forming a compact typology that optimises outlook and daylight.
- Creating a family of buildings, tied together at the base by the Train Shed.
- Developing an architectural language that responds to the industrial character of Lillie Sidings.

► Refer to Design Code / Lillie Sidings / Built form / Common base (EC.PA.C).

## Illustrative design response

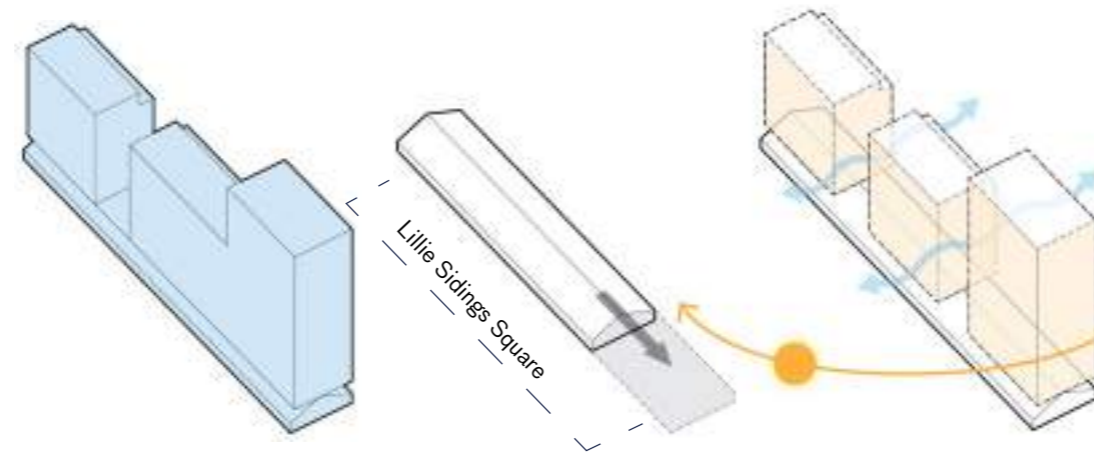

Maximum envelope defined by the Parameter Plans

Retention and extension of the Train Shed structure

Maximised permeability and south-facing façades

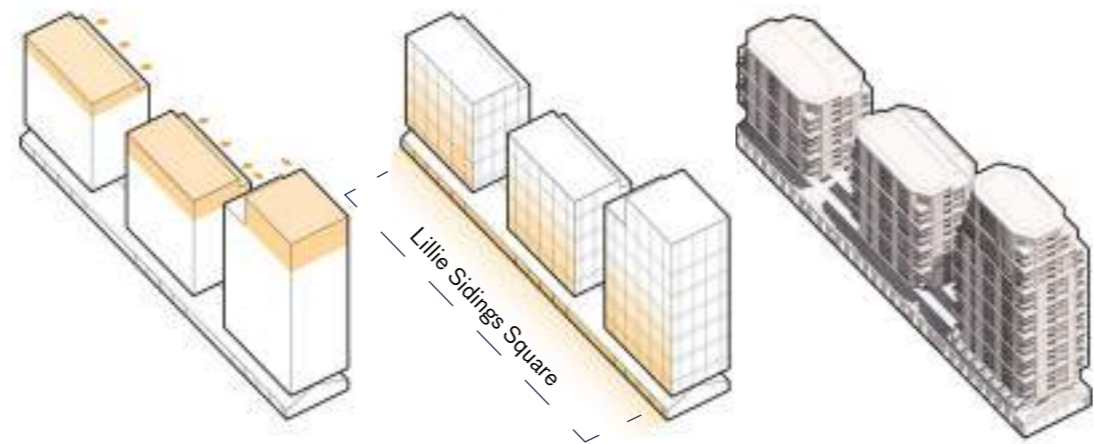

Clearly articulating building tops

Ground Floor façades activating the square

Sculpted forms with corner balconies



A cultural destination is located in the re-purposed Train Shed.

Residential entrances are laid out and located to maximise the flexibility of the Train Shed Ground Floor.



Illustrative Ground Floor plan - mixed-use

Gaps between the buildings allow sunlight through the blocks.

A consistent layout helps to create a family of buildings.



Illustrative typical Upper Floor plan - residential use





## 6.9 Lillie Sidings | Built Form

The Train Shed | Perimeter blocks | Transition blocks

### Cultural activation

The Train Shed accommodates a destination dining venue or food hall with a flexible events and performance space. It serves as a testbed for experimental culture, offering spaces for immersive performance, digital art, fashion, and training.

- ▶ Refer to *Design and Access Statement Volume 1: Outline Component / The Illustrative Masterplan / Sitewide proposals / A cultural destination (EC.PA.08)*.



Illustrative drawing of the cultural venue at the Train Shed

### Illustrative design response



Illustrative eye-level view of the food and cultural venue within the Train Shed



Illustrative view of Lillie Sidings Square, with a food market within the Train Shed



Illustrative eye-level view of the cultural venue within the Train Shed during a music performance



## 6.9 Lillie Sidings | Built Form

The Train Shed | Perimeter blocks | Transition blocks

### The Train Shed

The key principles that characterise the Train Shed are described in the Design Code. These are demonstrated in the illustrative proposal, including:

**1** Activating Lillie Sidings Square

The Ground Floors have a permeable design to maximise interaction between the Train Shed and the square.

**2** Using the façade rhythm of the existing bays

Capturing the industrial heritage of the existing depot, the upper residential buildings respond to the rhythm of the existing bays.

**3** Extending the existing Train Shed footprint

The design retains the base building of the existing depot and explores extending the footprint, but creating a new expression to clearly distinguish between old and new.



Key plan

### Illustrative design response



Eye-level view of the Train Shed activating the public realm at Lillie Sidings Square

# 6.9 Lillie Sidings | Built Form

The Train Shed | Perimeter blocks | Transition blocks

## Perimeter blocks

Plot Code: WK10, WK11  
Typology: Perimeter block

The perimeter blocks are characterised by stepped courtyard buildings that accommodate a range of residential layouts and include external amenity spaces.

The key principles that characterise the perimeter blocks are described in the Design Code. These are demonstrated in the illustrative proposal, including:

- Drawing upon a familiar residential courtyard block typology.
- Creating articulated façades that respond to the scale of Aisgill Avenue in terms of geometry and urban grain.
- Offering active retail frontage onto Lillie Siding Square and residential front doors along both Walks and Aisgill Lane.
- Accommodating back-of-house uses beneath a Ground Floor podium.
- Providing opportunities for external amenity space - in addition to the public open spaces across the masterplan.

► Refer to Design Code / Lillie Sidings / Built form / Perimeter Block (EC.PA.C).

## Illustrative design response

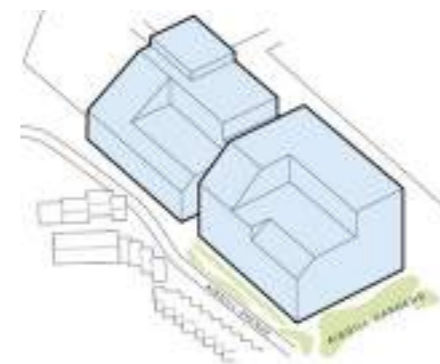

Maximum envelope defined by the Parameter Plans

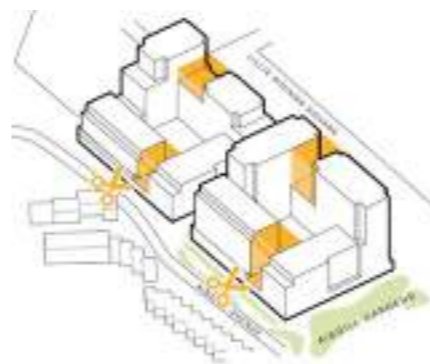

Introduce breaks to optimise daylight to external amenity spaces

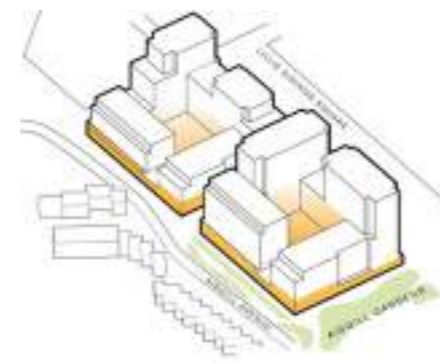

Residential front door and ancillary spaces activate the Ground Floor

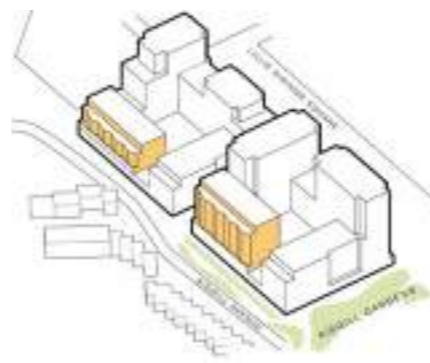

Articulation of façades respond to Aisgill Avenue in scale, geometry and urban grain



Overall coherence - read as a family of buildings



Illustrative design response

- Shops, cafés and restaurants along Lillie Sidings Square
- Residential front doors on residential street
- Servicing and waste consolidated under the raised communal amenity space, maximising opportunity for active frontages.
- Community uses at Ground Floor opening onto Aisgill Gardens



Plot WK10



Illustrative Ground Floor plan - mixed-use

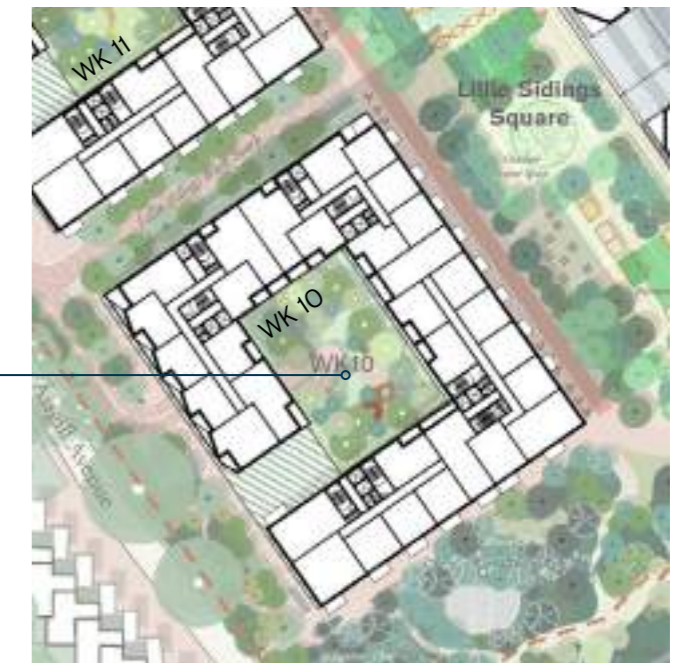

Illustrative typical Upper Floor plan - residential use

Raised communal amenity space

# 6.9 Lillie Sidings | Built Form

The Train Shed | Perimeter blocks | Transition blocks

## Perimeter blocks

The key principles that characterise the perimeter blocks are described in the Design Code. These are demonstrated in the illustrative proposal, including:

- 1 Creating a permeable edge  
A linear landscaped edge stitches the Proposed Development into the existing context and provides a shared amenity for existing and new residents.
- 2 Planting heights for permeability  
Raised tree canopies provide a visual connection, while gaps in planting create permeability throughout the public realm.
- 3 Responding to the existing context  
An articulated massing responds to the grain of the Estates, creating a design that stitches in with the surrounding neighbourhood.
- 4 Creating a residential frontage on Aisgill Lane  
Residential front doors open onto the lane and extend the residential character of Aisgill Avenue.



Key plan

## Illustrative design response



Eye-level view of the perimeter block along Aisgill Lane



A building design responding to the grain of the existing context.

A visual connection maintains sight lines across the Site boundary.

A permeable, linear landscape interfaces with the neighbouring Estates.

A permeable edge to Aisgill Gardens enabling a key east-west route across the Site.

Eye-level view along Aisgill Avenue and Aisgill Lane

# 6.9 Lillie Sidings | Built Form

The Train Shed | Perimeter blocks | Transition blocks

## Transition blocks

Plot Code: WK05, WK07, WK12  
Typology: Transition block

The transition blocks follow the geometry of the boulevard, creating an irregular perimeter block typology. They provide a transition between two Character Areas as well as a transition in height, stepping from the taller edge along the railway down to the lower Estate context.

The key principles that characterise the transition blocks are described in the Design Code. These are demonstrated in the illustrative proposal, including:

- Using Ground Floor frontages to create a continuous active edge that spills out into the public realm.
- Creating a legible base that helps define the crescent and activates its frontages.
- Addressing the street with commercial uses.
- Providing residential amenity space located within raised courtyards.
- Strategically locating massing to optimise south-facing daylight.

► Refer to Design Code / Lillie Sidings / Built form / Transition Block (EC.PA.C).

## Illustrative design response

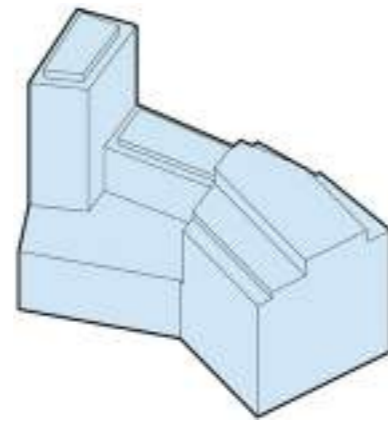

Maximum envelope defined by the Parameter Plans

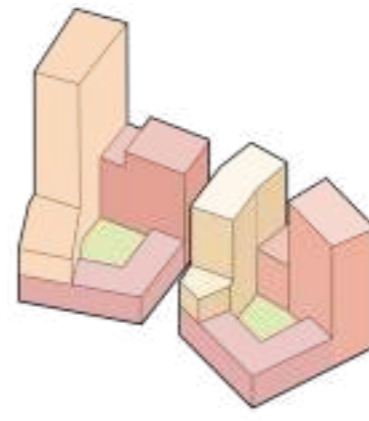

A family of buildings through a coherent approach to architectural treatment

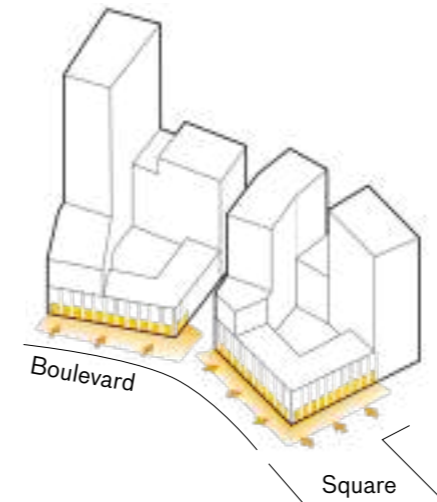

Building base addressing the boulevard with predominant commercial and retail uses

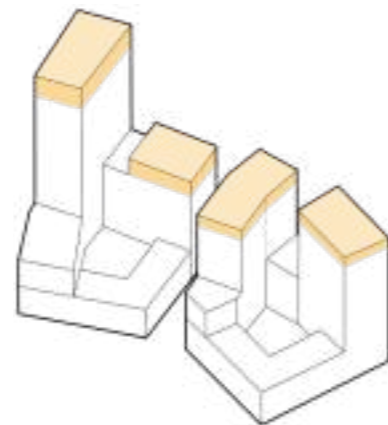

Expression of building tops



Addressing environmental conditions along the railway corridor and A4



Illustrative design response



Retail and workspace uses at Ground Floor  
Residential entrances located along walks



Illustrative Ground Floor plan - mixed-use

Raised communal amenity space



Illustrative typical Upper Floor plan - residential use



## 6.9 Lillie Sidings | Built Form

The Train Shed | Perimeter blocks | Transition blocks

### Transition blocks

The key principles that characterise the transition blocks are described in the Design Code. These are demonstrated in the illustrative proposal, including:

**1** Expressing Ground Floor frontages

Ground floor frontages along the square and West Kensington Boulevard create a continuous active edge that spills out into the public realm.

**2** Activating the north-south route

The blocks lead people from the square into the West Kensington Boulevard Link, creating a clearly legible sequence between open space and primary routes.

**3** Creating prominent corners

Prominent corners are designed with an emphasis to help reinforce a spatial hierarchy and assist with wayfinding in the public realm.

**4** Designing a coherent 'family of buildings'

Buildings are designed with a coherence in material, tone and composition to be read as part of a cluster of buildings.



Key plan

### Illustrative design response



Eye-level view showing the transition block at the northern end of Lillie Sidings Square

# West Kensington







# 6.10 West Kensington | Overview

The West Kensington Character Area helps open up the Site and extends the neighbourhood towards West Cromwell Road. Its proximity to the station and key arterial road offer the opportunity for a new workspace cluster, that forms a gateway along the route into central London.

This section illustrates how the Character Area has been developed alongside the Control Documents. Key principles that characterise Lillie Sidings are set out on the image on the right.

► Refer to Design Code / West Kensington (EC, P.A.C).

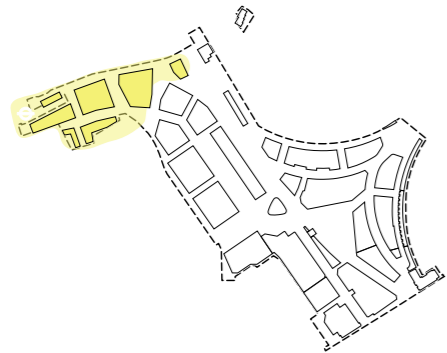

Location of West Brompton Character Area

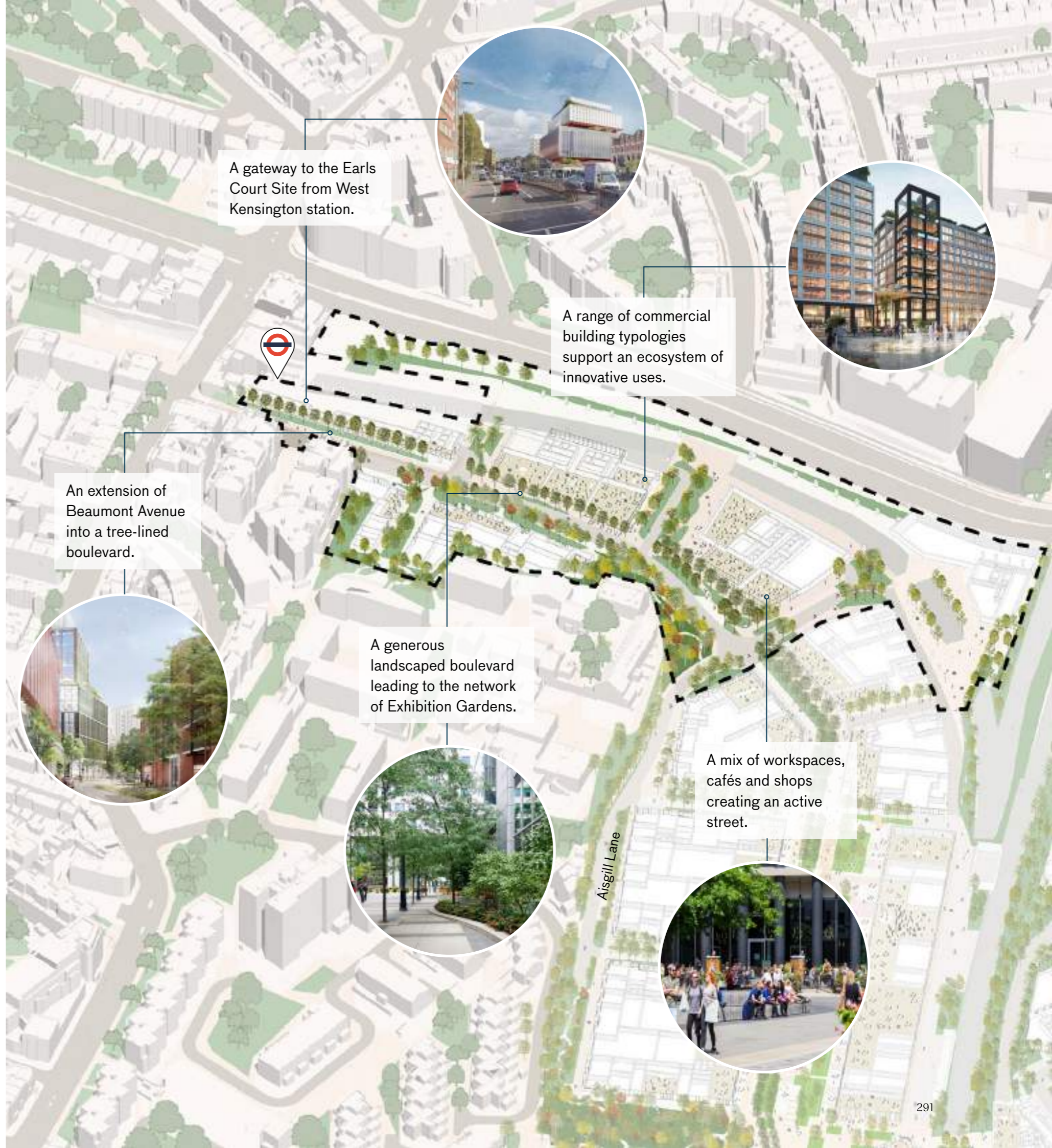

A gateway to the Earls Court Site from West Kensington station.



A range of commercial building typologies support an ecosystem of innovative uses.



An extension of Beaumont Avenue into a tree-lined boulevard.



A generous landscaped boulevard leading to the network of Exhibition Gardens.



A mix of workspaces, cafés and shops creating an active street.



# 6.10 West Kensington | Public Realm

A legible network of green streets and spaces stitches the public realm into the surrounding context, and creates a landscaped route to West Kensington station.

Key spaces and routes are outlined in the Control Documents including:

### Spaces and routes

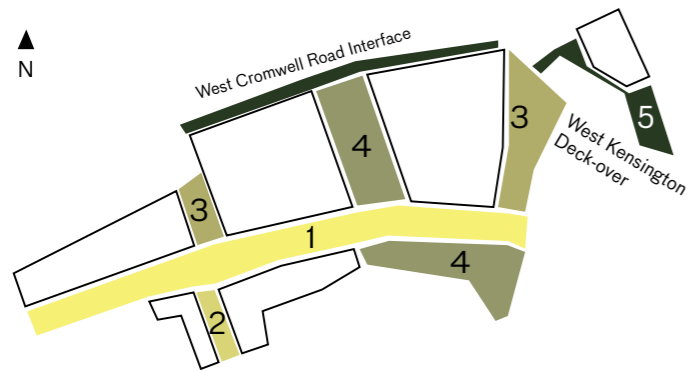

### Access and movement

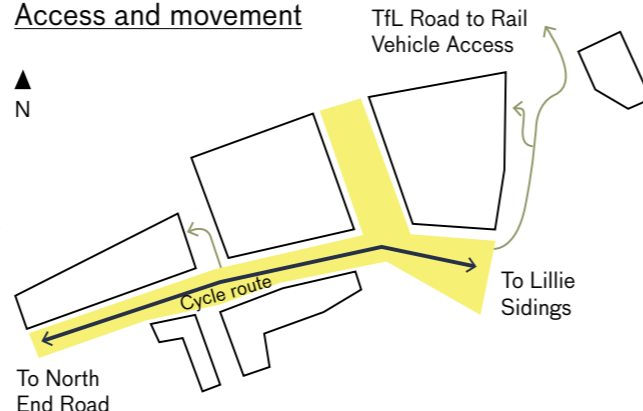

- 1 West Kensington Boulevard
- 2 Gibbs Walk
- 3 West Kensington Passage W & E
- 4 West Kensington Place N & S
- 5 West Kensington Deck-over, West Cromwell Road Interface

- Pedestrian-friendly public realm (Cyclist on demarcated route)
- Vehicle access
- Servicing routes

- ▶ Refer to Design Code / West Kensington / Landscape (EC.P.A.C).
- ▶ Refer to Design Code / Sitewide / Landscape (EC.P.A.C).

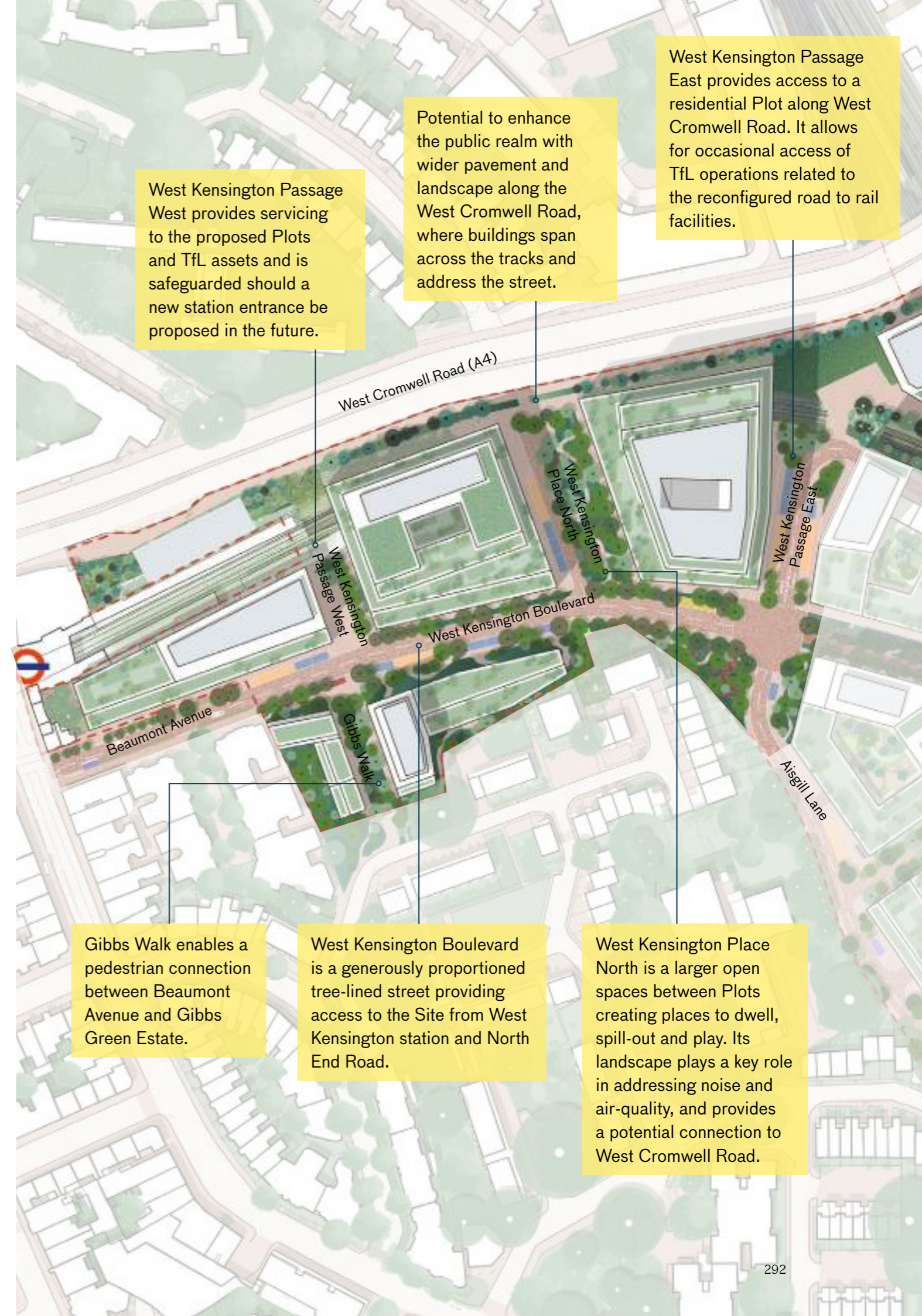

West Kensington Passage West provides servicing to the proposed Plots and TfL assets and is safeguarded should a new station entrance be proposed in the future.

Potential to enhance the public realm with wider pavement and landscape along the West Cromwell Road, where buildings span across the tracks and address the street.

West Kensington Passage East provides access to a residential Plot along West Cromwell Road. It allows for occasional access of TfL operations related to the reconfigured road to rail facilities.

Gibbs Walk enables a pedestrian connection between Beaumont Avenue and Gibbs Green Estate.

West Kensington Boulevard is a generously proportioned tree-lined street providing access to the Site from West Kensington station and North End Road.

West Kensington Place North is a larger open spaces between Plots creating places to dwell, spill-out and play. Its landscape plays a key role in addressing noise and air-quality, and provides a potential connection to West Cromwell Road.

# 6.10 West Kensington | Public Realm

Boulevard | Walk | Place

## West Kensington Boulevard

West Kensington Boulevard is a wide and generously landscaped street that creates a prominent address for the workspace cluster, with active frontages and clearly legible entrances.

The key principles that characterise West Kensington Boulevard are described in the Design Code. These are demonstrated in the illustrative proposal, including:

- Providing adequate space for pedestrian, cycle and vehicular movement.
- Integrating a generous landscape with sustainable drainage measures along it.
- Integrating colonnades and set-backs to provide shelter and celebrate primary workspace entrances along the boulevard.
- Integrated car and cycle parking within the landscaped environment and putting pedestrian comfort and nature first.

► Refer to Design Code / West Kensington / Landscape / West Kensington Boulevard (EC.P.A.C).

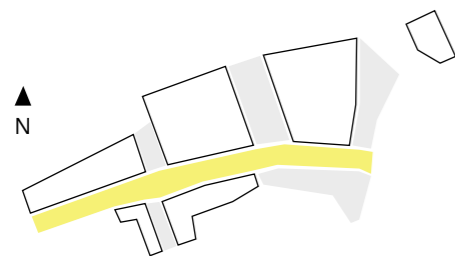

## Illustrative design response

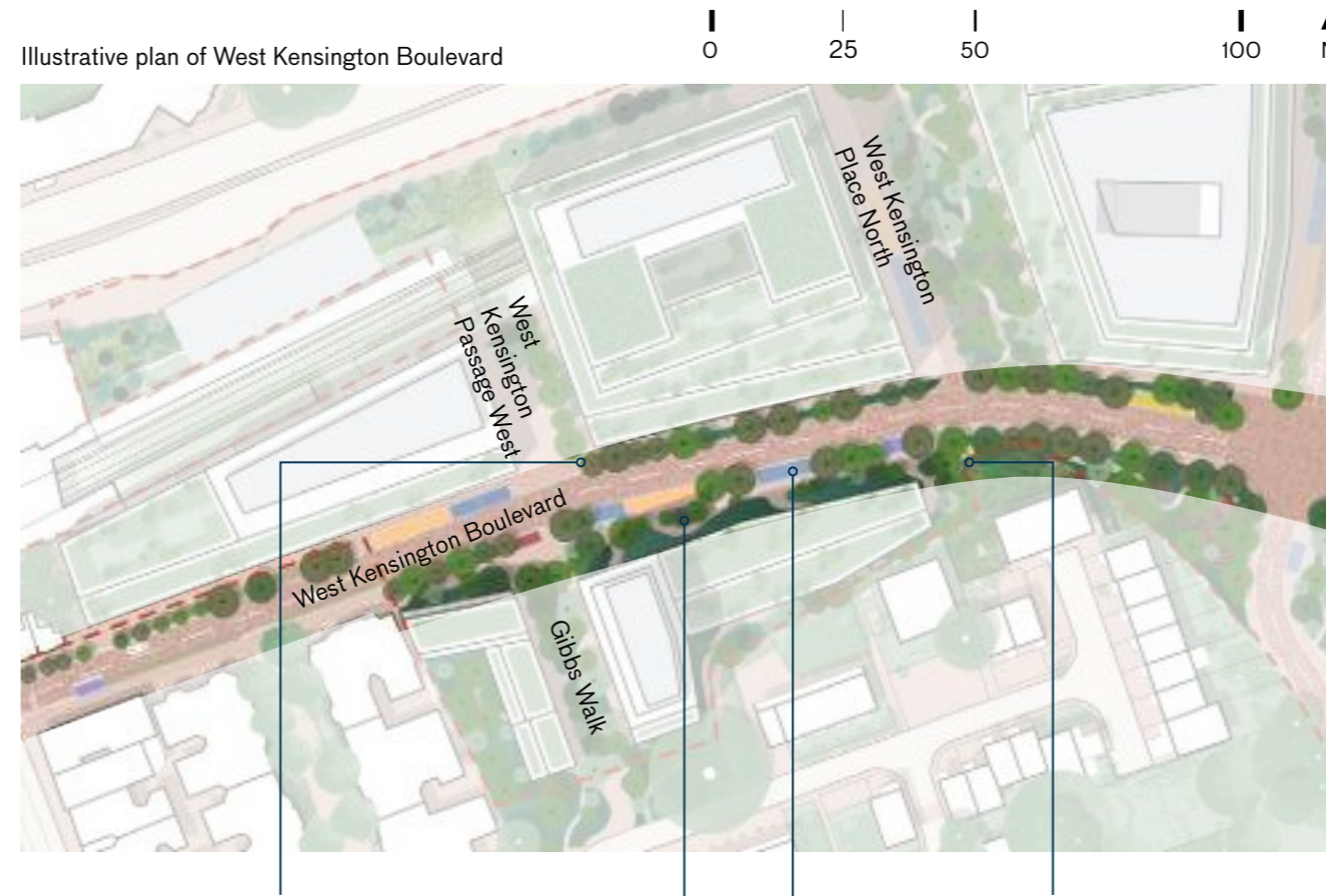

Cafés, convenience, retail and services to support the working population and complement the existing offer on North End Road.

Play on the way integrated into the public realm.

Car parking integrated into the landscaped street.

Tree-lined street with biodiverse planting strategies and SuDS.



Illustrative view of West Kensington Boulevard



Tree-lined street integrating hard and soft landscaping



Double height colonnade provides shelter and mediates between the internal and external public spaces

# 6.10 West Kensington | Public Realm

Boulevard | Walk | Place

## West Kensington Boulevard

The key principles that characterise West Kensington Boulevard are described in the Design Code. These are demonstrated in the illustrative proposal, including:

- 1** Shared central movement route  
A shared cycle and vehicle route along the boulevard connecting the area with the wider network of streets.
- 2** Climate resilient streetscapes and SuDS  
The planting design of the boulevard incorporates climate resilient species, as well as the opportunity for SuDS features.
- 3** Extending local character  
Planting and use of materials ensure that the new public realm ties into existing local character.
- 4** Planting that frames entrances  
Planting in the public realm helps to reinforce Ground Floor frontages and frames entrances.



Key plan

## Illustrative design response



Eye-level view showing activation and commercial uses along the West Kensington Boulevard



# 6.10 West Kensington | Public Realm

Boulevard | Walk | Place

## Gibbs Walk

Gibbs Walk\* provides a new pedestrian north-south route with a residential character and planting similar to a traditional mews.

The key principles that characterise Gibbs Walk\* are described in the Design Code. These are demonstrated in the illustrative proposal, including:

- Creating a potential future link to the adjacent Estate (subject to third party agreement).
- Activating Ground Floors with residential front doors.
- Potential to integrate community or leisure space addressing the walk.

\*Gibbs Walk has been incorporated in discussion with LBHF and relies on the Local Planning Authority enabling the connection outside of the Planning Application Boundary.

► Refer to Design Code / West Kensington / Landscape / Gibbs Walk (EC.PA.C).

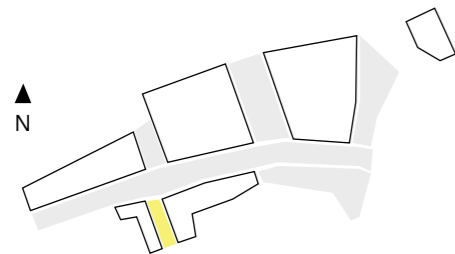

## Illustrative design response

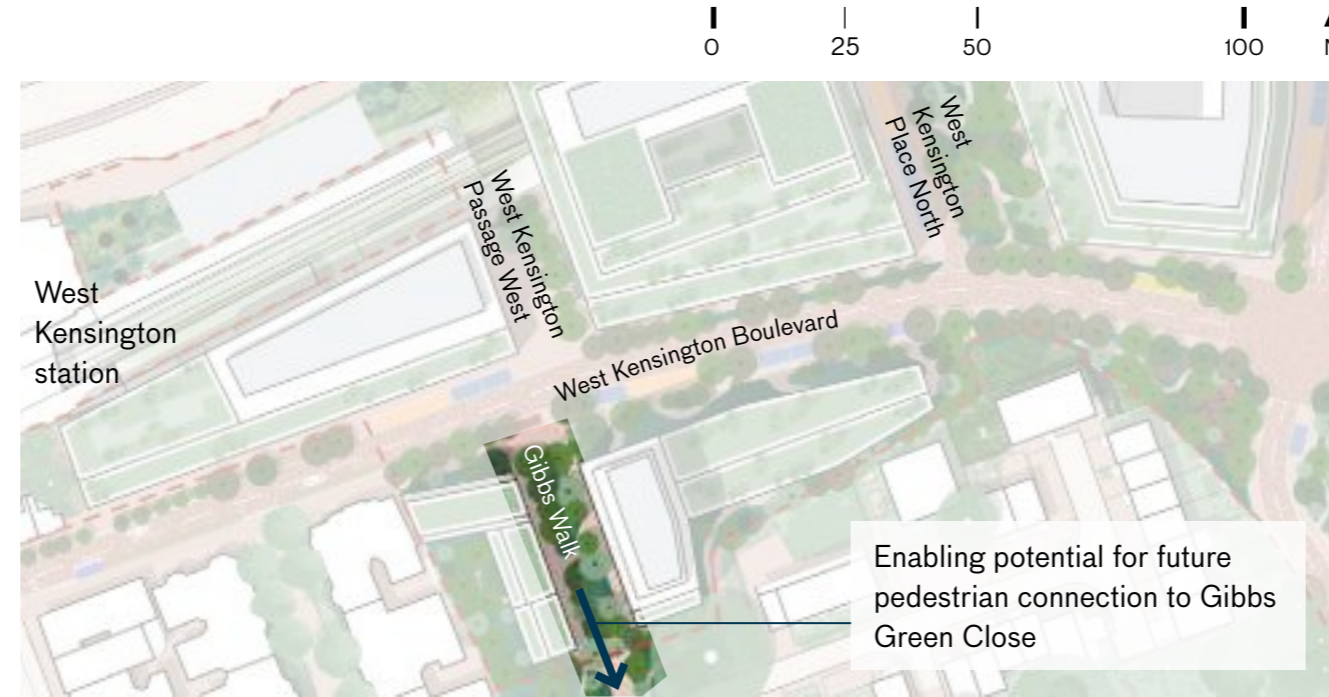

Illustrative plan of West Kensington Passages



Illustrative street section

Generously planted walk

Local amenity encourages dwelling and informal play



Example of a generously landscaped walk

# 6.10 West Kensington | Public Realm

Boulevard | Walk | Place

## West Kensington Place North and South

Green open spaces along the boulevard create moments that can accommodate outdoor meeting, lunch spots, socialising and play in a naturalistic landscape setting.

The key principles that characterise West Kensington Place North and South are described in the Design Code. These are demonstrated in the illustrative proposal, including:

- Creating a landscaped space with opportunities for play.
- Providing a landscape that integrates planting and playful street furniture.
- Addressing noise and air-quality constraints from West Cromwell Road and providing a potential connection to it.

Key requirements of West Kensington Place South are described in the Control Documents and explored in the Illustrative Masterplan including:

- Integrating planting and the opportunity for SuDS.
- Creating a landscaped buffer adjacent to the existing residential properties.
- Integrating opportunities for play including naturalistic play equipment.

## Illustrative design response

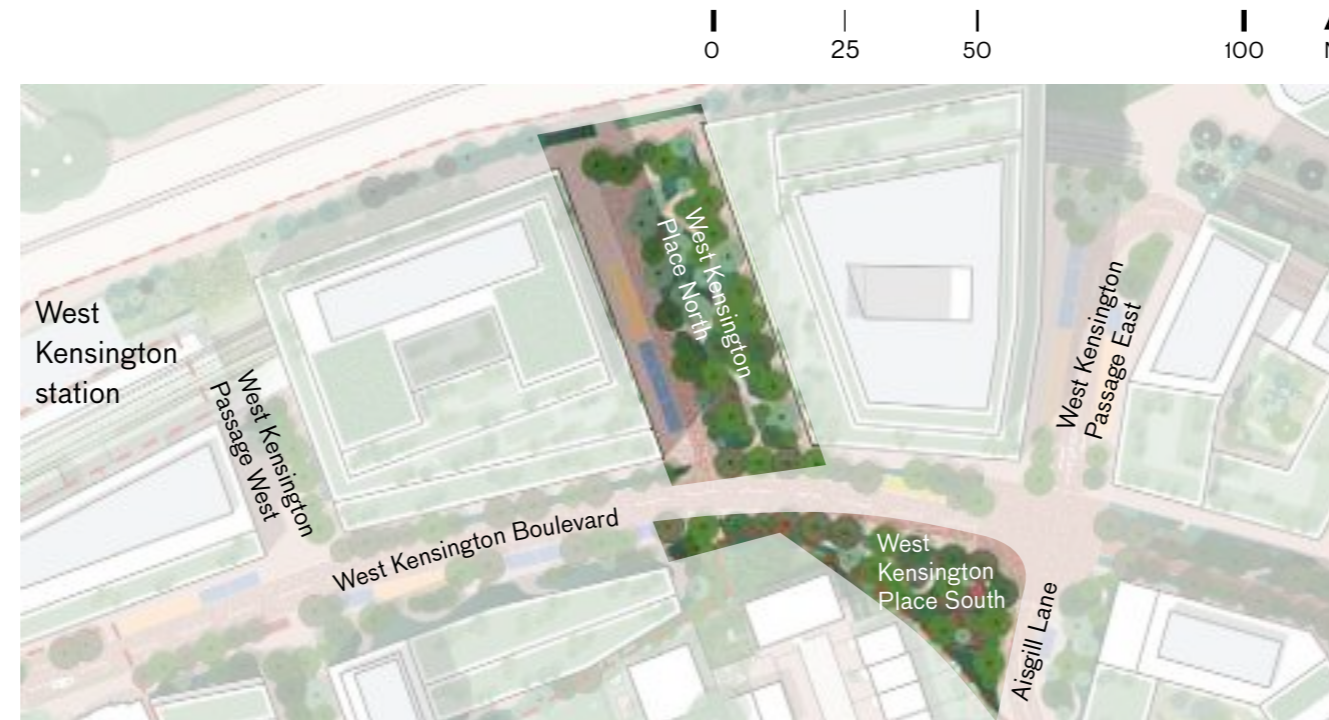

Illustrative plan of West Kensington Place North & South



Illustrative precedents of integrated play space

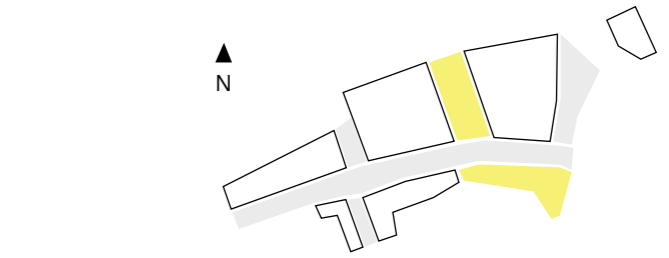

Illustrative precedents showing a local square that is addressed by active frontages



Illustrative precedents showing the integration of green and blue infrastructure

# 6.10 West Kensington | Built Form

The new innovation cluster next to West Kensington station creates a gateway to Central London along West Cromwell Road and stitches into the existing neighbourhood by integrating mid-scale residential blocks.

The Illustrative Masterplan responds to key built form principles outlined in the Control Documents including:

- Building scales and footprints that respond to the predominant use and their context.
- Establishing a presence and creating a gateway along West Cromwell Road.
- Articulating the buildings horizontally and vertically to establish clearly legible bases that respond to human and local scale.
- Creating a set of buildings with a distinctive and contemporary identity that signposts the innovation cluster.

West Kensington is comprised of the following built form typologies:

- Large-footprint
- Mid-scale
- Standalone
- ▶ Refer to Design Code / West Kensington / Built form (EC.PA.C).
- ▶ Refer to Design Code / Sitewide / Built form (EC.PA.C).
- ▶ Refer to Development Specification (EC.PA.A).

The below plans outline the land use emphasis of the Illustrative Masterplan within the Character Area. Full detail of the permitted land uses are described in the Development Specification.

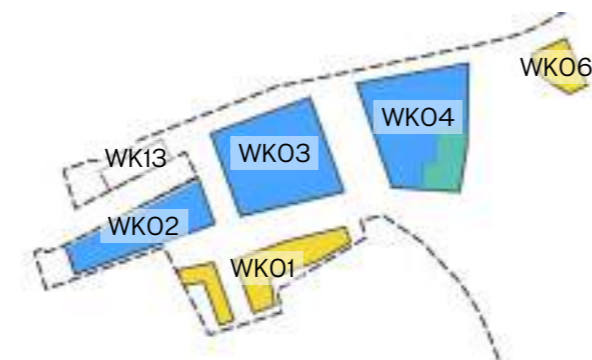
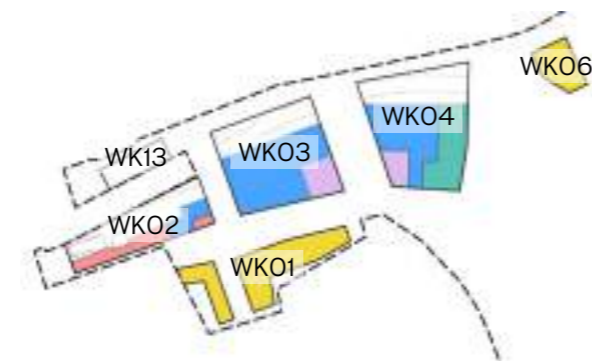

<span style="color: yellow;">■</span> Residential	<span style="color: purple;">■</span> Food & Beverage
<span style="color: blue;">■</span> Workspace	<span style="color: green;">■</span> Community
<span style="color: red;">■</span> Retail	<span style="color: teal;">■</span> Leisure

Mid-scale workspace blocks form a linear frontage along West Kensington Boulevard that complete and transition into Beaumont Avenue. They establish an intermediate scale that responds to local context and transitions up towards taller buildings along West Cromwell Road.

Large-footprint workspace blocks establish the new innovation cluster and create a presence and gateway along West Cromwell Road. They are scaled to accommodate a broad variety of flexible workspaces, attracting a diverse range of tenants.

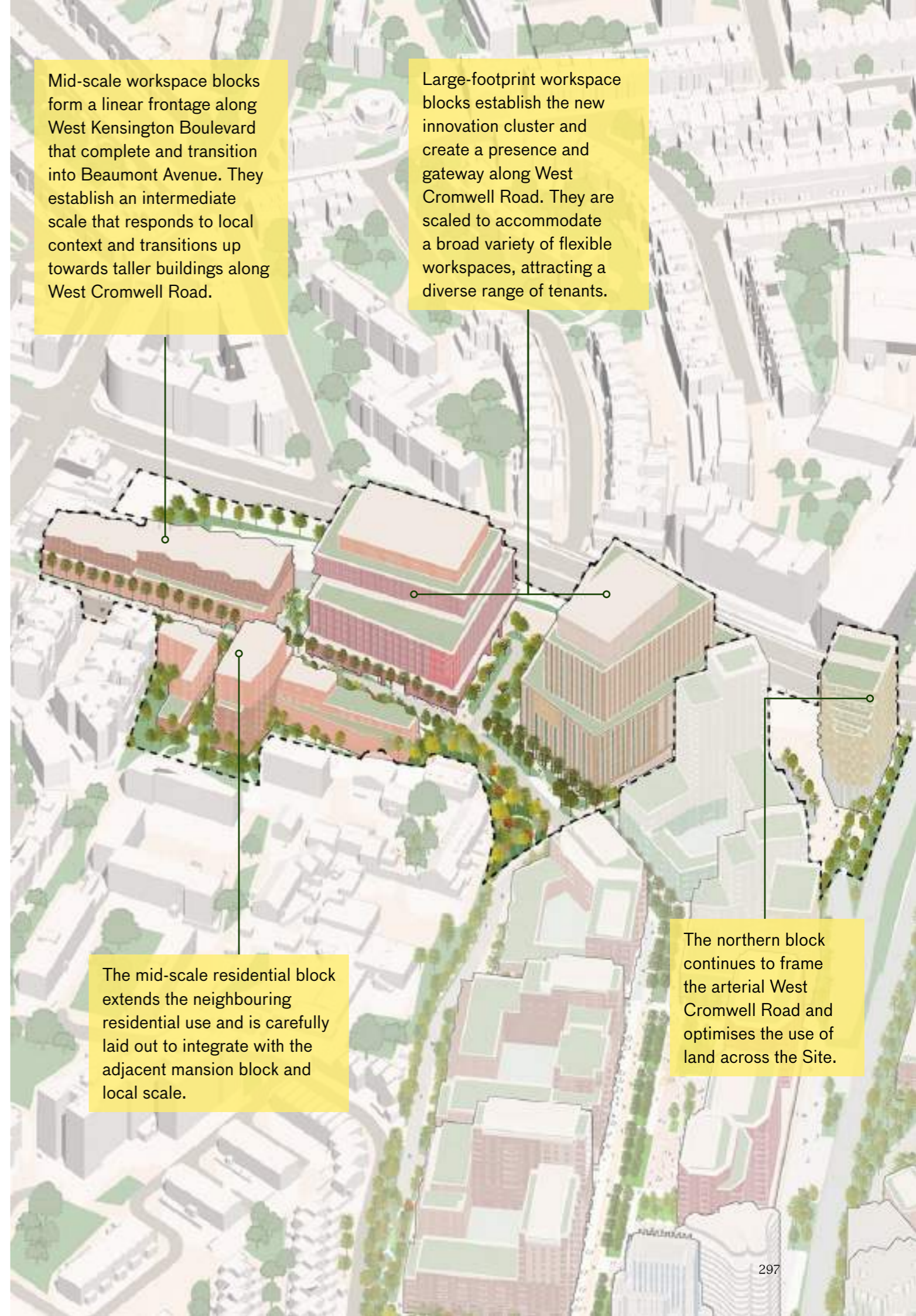

The mid-scale residential block extends the neighbouring residential use and is carefully laid out to integrate with the adjacent mansion block and local scale.

The northern block continues to frame the arterial West Cromwell Road and optimises the use of land across the Site.

# 6.10 West Kensington | Built Form

Workspace blocks | The northern block | Mid-scale block

## Workspace blocks

Plot Code: WK02, WK03, WK04  
 Typology: Mid-scale & Large-footprint

Workspace blocks at West Kensington form a family of buildings with a distinct and complementary identity and character. They reinforce the gateway location and create a legible address along the boulevard.

The key principles that characterise the workspace blocks are described in the Design Code. These are demonstrated in the illustrative proposal, including:

- Creating flexible commercial spaces that attract small, medium, and large enterprises and businesses.
- Establishing a series of datums and setbacks that relate to local scale.
- Integrating accessible, landscaped roof terraces and providing external space for the workspace users.
- Articulating the base of buildings to define a clear Ground Floor datum, framing and activating the boulevard with cafés, shops, and workspace entrances.

▶ Refer to Design Code / West Kensington / Built form / Large-footprint (EC.PA.C).

▶ Refer to Design Code / West Kensington / Built form / Mid-scale (EC.PA.C).

## Illustrative design response

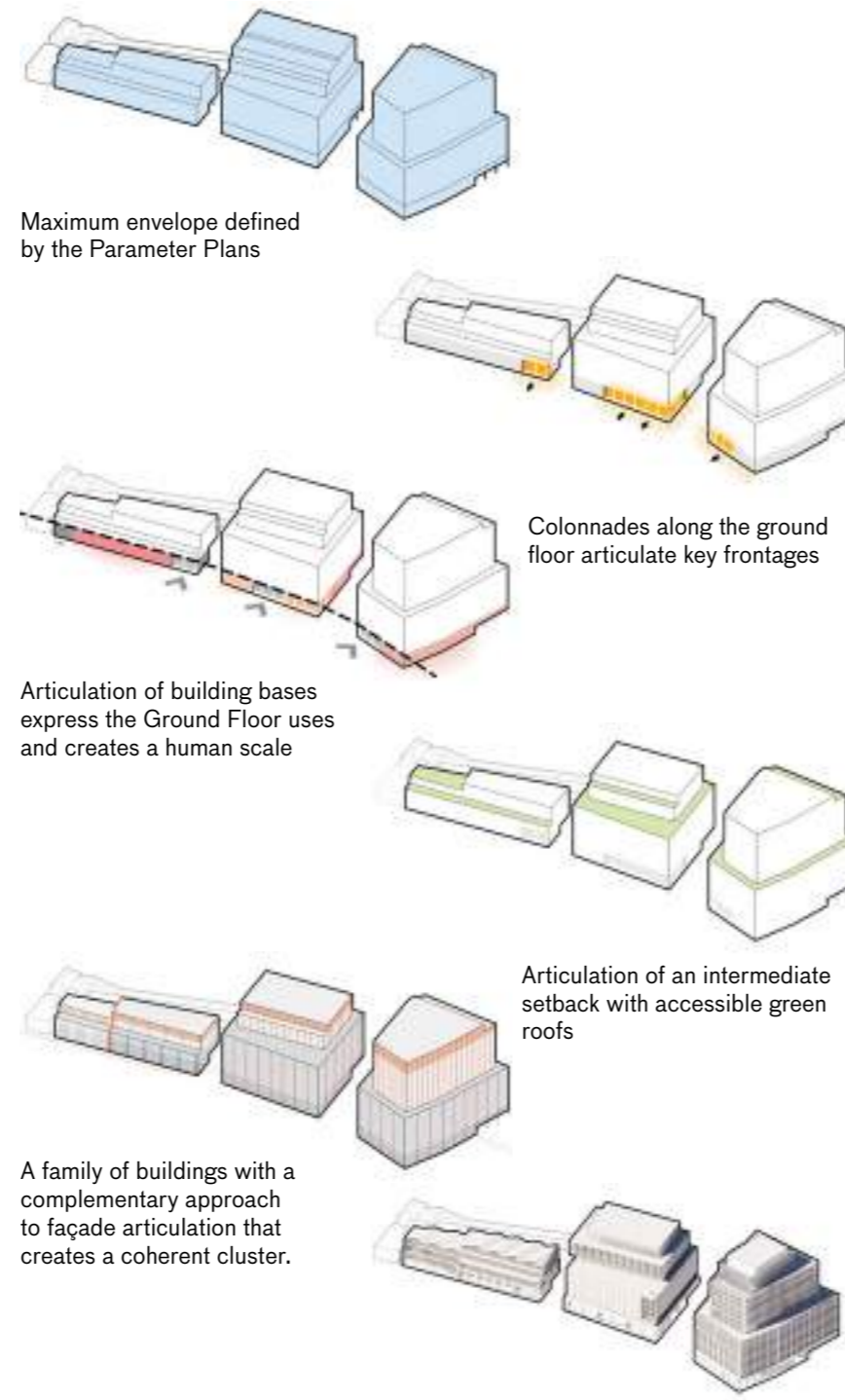

Illustrative design response

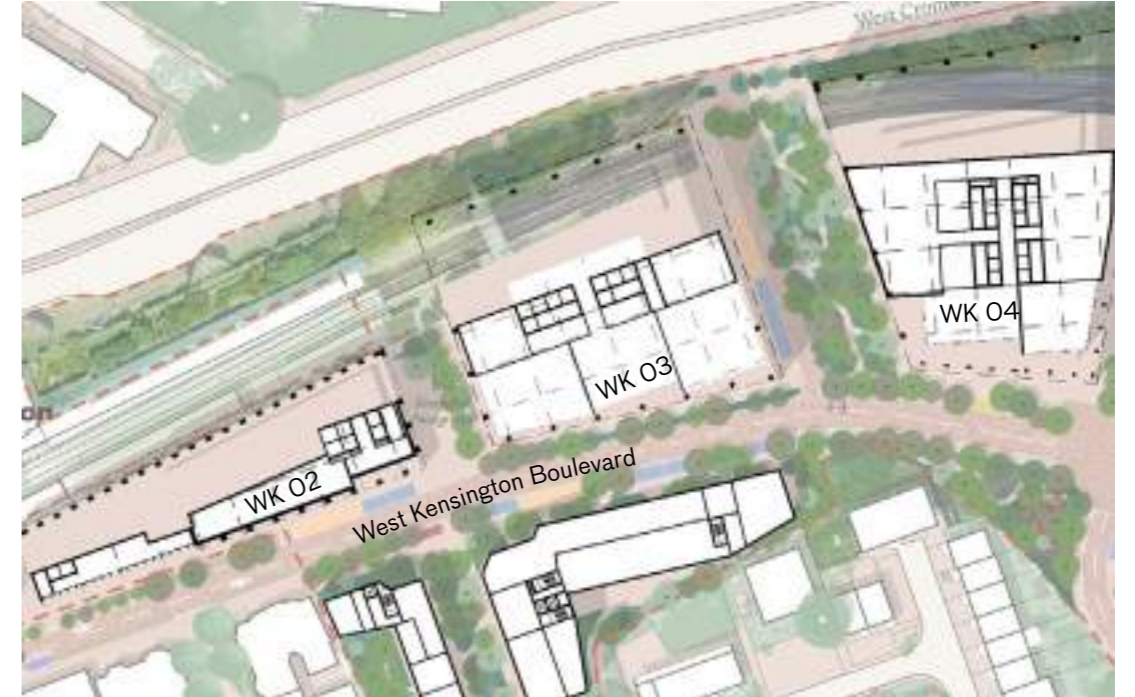

Illustrative Ground Floor plan - mixed-use

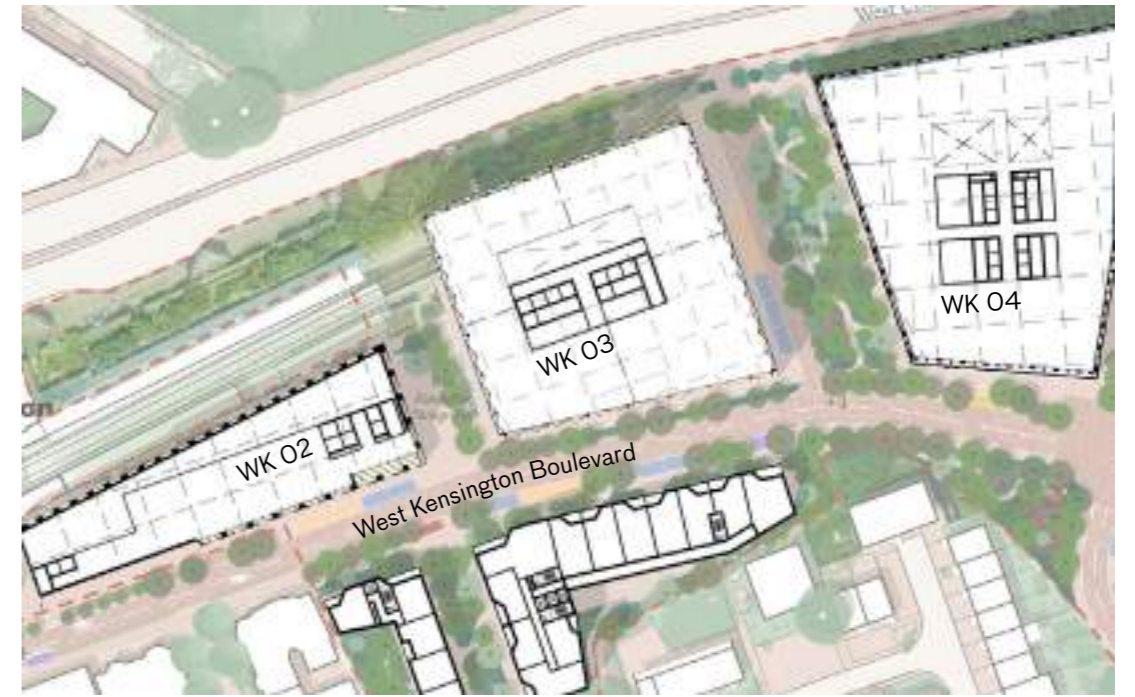

Illustrative typical Upper Floor plan - workspace use





# 6.10 West Kensington | Built Form

Workspace blocks | The northern block | Mid-scale block

## Workspace blocks

The key principles that characterise the workspace blocks are described in the Design Code. These are demonstrated in the illustrative proposal, including:

**1** Creating a gateway and marker building

Buildings fronting West Cromwell Road form a marker and a gateway into London from the east. Distinctive façade materials and expression create special moments along the movement corridor.

**2** Establishing datums and green roofs

Intermediate datums create a relationship with surrounding buildings whilst providing opportunity to integrate accessible green roofs and nature.



Key plan

## Illustrative design response



Eye-level view showing how buildings at West Kensington create a distinct identity and gateway along West Cromwell Road

# 6.10 West Kensington | Built Form

Workspace blocks | The northern block | Mid-scale block

## Workspace blocks

The key principles that characterise the workspace blocks are described in the Design Code. These are demonstrated in the illustrative proposal, including:

- 1** Creating meaningful stepping  
Façade expression within buildings should contain meaningful stepping to ensure clarity and hierarchy of massing, and provide a mediation in scale perceived from Mornington Avenue and along the West Cromwell Road corridor.
- 2** Distinguishing the proposal from the foreground  
The design of buildings should have a distinctive rhythm and composition that differ from other buildings in the view, to avoid coalescence in the massing and reduce visual impact on heritage assets and their setting.
- 3** Creating green roofs  
Establish meaningful setbacks to integrate nature and green roofs for workspace users to access.

► Refer to Design Code / West Kensington / Built form / Impacts on heritage and townscape (EC.PA.C).



Key plan

## Illustrative design response



Eye-level view looking south along Mornington Avenue illustrating how proposals could respond to the existing context

# 6.10 West Kensington | Built Form

Workspace blocks | The northern block | Mid-scale block

## The northern block

Plot Code: WK06  
Typology: Standalone

This stand-alone residential block responds to the challenging environmental conditions of the West Cromwell Road and railway lines, and steps down toward the residential community to the south creating a number of south facing, landscaped terraces.

The key principles that characterise the northern block are described in the Design Code. These are demonstrated in the illustrative proposal, including:

- Creating a Site specific approach to layout\* and building envelope.
- A varied facade composition with punched openings that change in size and are smaller facing West Cromwell Road to address noise and air quality conditions.
- Integrating with the reconfigured TfL Road to Rail Vehicle (RRV) facility and optimising the use of brownfield land.

\*The block presents an opportunity to connect the level change between the Site and West Cromwell Road that could increase the north-south connectivity at the interface with West Cromwell Road.

► Refer to Design Code / West Kensington / Built form / Stand-alone (EC.PA.C).

## Illustrative design response

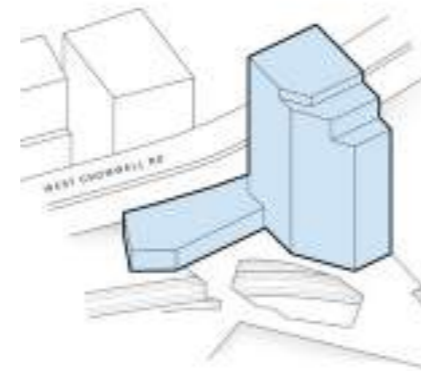

Maximum envelope defined by the Parameter Plans

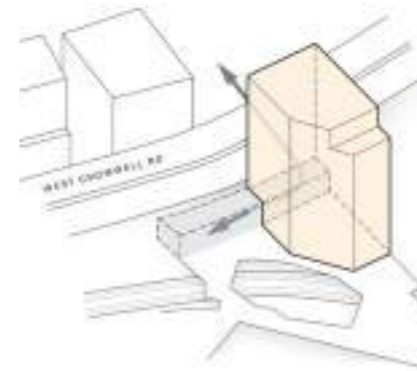

Integration with reconfigured TfL Road to Rail Vehicle (RRV) facility



Exploring prefabrication construction on constrained Site

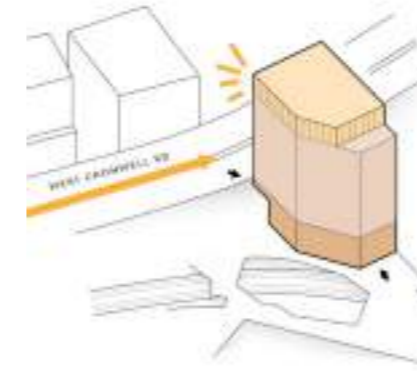

Provides building frontage continuity along West Cromwell Road

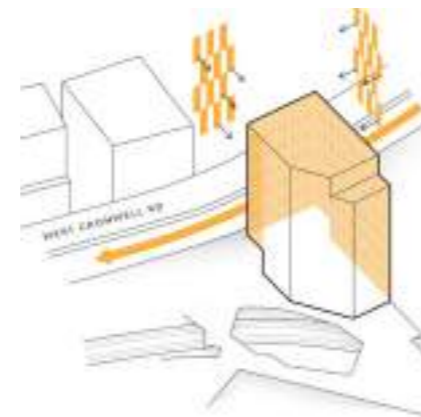

Façade responds to environmental Site conditions

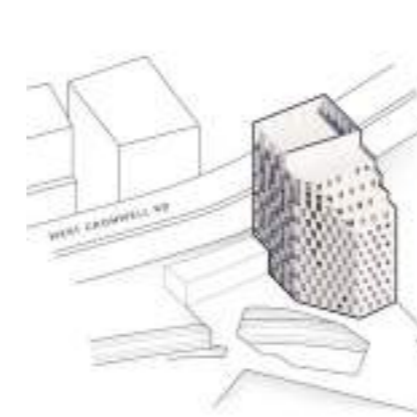

Illustrative design response

A TfL Road to Rail Vehicle (RRV) facility is reconfigured within the building footprint

Plot is accessed via an existing bridge over the exposed underground lines entering West Kensington station

Planting screens residential uses from rail infrastructure

Roof of RRV facility landscaped to provide visual amenity to residents within surrounding buildings

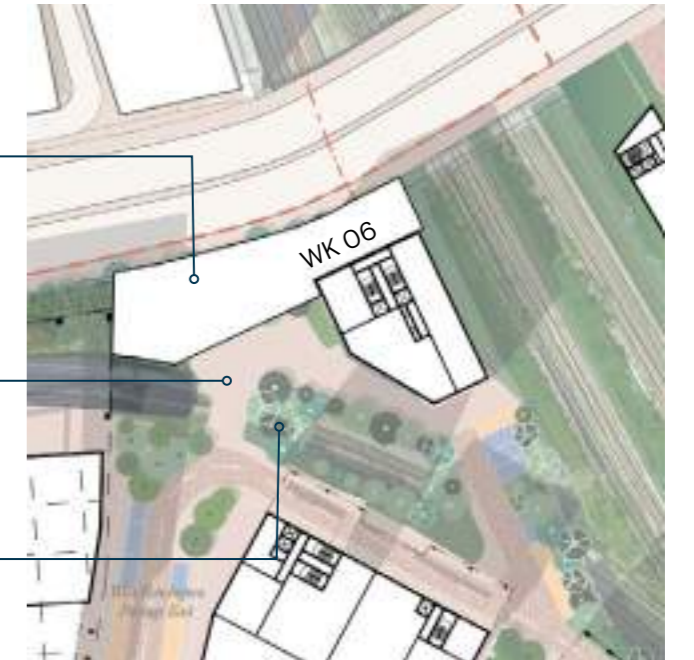

Illustrative Ground Floor plan - predominantly residential use



Illustrative typical Upper Floor plan - residential use

# 6.10 West Kensington | Built Form

Workspace blocks | The northern block | Mid-scale block

## Mid-scale block

Plot Code: WK01  
Typology: Mid-scale

The mid-scale residential blocks form the southern edge of West Kensington Boulevard and respond to the façade rhythm and composition of the adjacent mansion block typologies on Beaumont Avenue.

The key principles that characterise the mid-scale block are described in the Design Code. These are demonstrated in the illustrative proposal, including:

- Responding to the height established by the mansion block along West Kensington Boulevard.
- Responding to the architectural language of the mansion blocks through façade articulation and rhythm.
- Creating a coherent building frontage along the boulevard.
- Creating an active frontage on the Ground Floor addressing the public realm.

► Refer to Design Code / West Kensington / Built form / Mid-scale (EC.PA.C).

## Illustrative design response

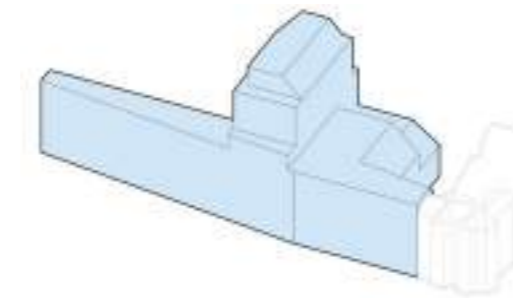

Maximum envelope defined by the Parameter Plans

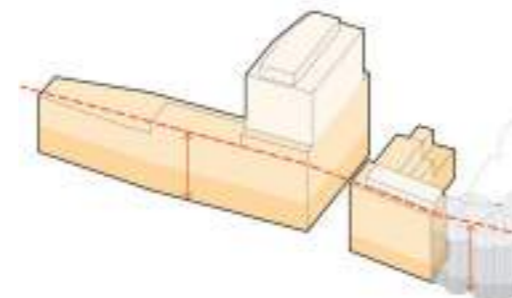

A layered composition & extension of existing datums

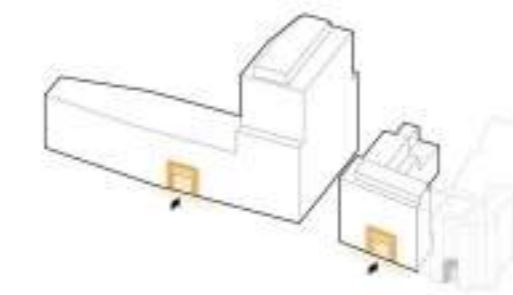

Expression of entrances

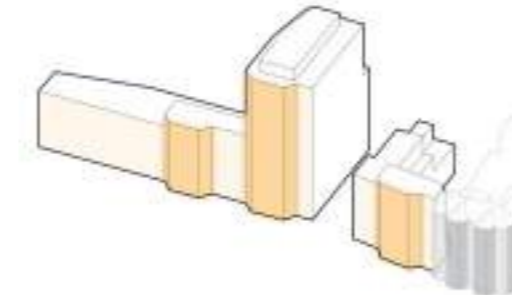

Integrating architectural mansion block components and articulation

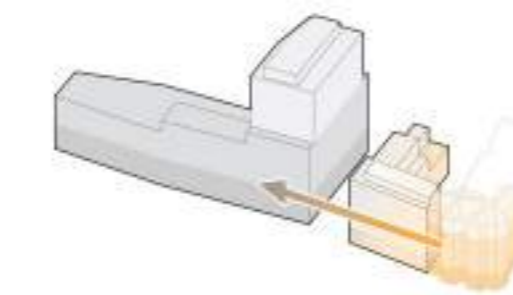

Emerging from local typologies



Illustrative design response

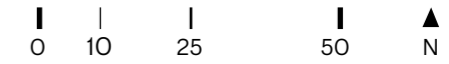

Facade aligns with neighbouring residential block

Gibbs Walk creates a pedestrian connection to the Estates



Illustrative Ground Floor plan - predominantly residential use

Recessed balconies articulate the façades and bays referencing local typologies



Illustrative typical Upper Floor plan - residential use



# 6.10 West Kensington | Built Form

Workspace blocks | The northern block | Mid-scale block

## Mid-scale block

The key principles that characterise the mid-scale block are described in the Design Code. These are demonstrated in the illustrative proposal, including:

- 1 Emerging from local typologies  
Façade articulation is a contemporary interpretation of local mansion blocks.
- 2 Extending existing datums  
The façade extends the datum established by the mansion blocks at Kensington Hall Gardens.
- 3 Creating a layered composition  
The layering and stepping of the façade expression defines a legible bottom, middle and top.
- 4 Expressing entrances  
Entrances are clearly legible; architectural expression such as high-contrasting materials are used to frame the entrances.



Key plan

## Illustrative design response



Eye-level view looking east along West Kensington Boulevard showing the residential proposal tying into the existing context



Commercial buildings form the northern innovation cluster and establish an address along West Kensington Boulevard.

Set backs in massing provide space for landscaped roofs and accessible terraces.

A generously-planted public realm amplifies nature and enhances biodiversity.

Clearly defined articulated steps in the building frame the boulevard and define an intermediate scale.

Boulevard facilitates vehicular and cycle access into the site, whilst providing generous pavements.

Massing steps down towards the neighbouring Estates.

The Ground Floor datum establishes a human scale with active frontages and workplace entrances.

Eye-level view looking north along West Kensington Boulevard



# 6.11 Flexible Plots

The Control Documents make provision for alternative uses from the baseline in certain locations, known as Flexible Plots.

The Parameter Plans define Development Zones within which Development Plots will come forward, and the Development Specification enables some flexibility between residential and commercial uses within some of these zones.

The Development Specification and Parameter Plans also enable the capacity for some other

uses to come forward as an alternative in select Development Zones as identified on the Parameter Plans (see extract below).

Please refer to the Development Specification and Parameter Plans for full information of the proposed land use allocation per Development Zone.

The Illustrative Masterplan has then been used to test some of the Flexible Plots in more detail to illustrate how some of the alternative uses could be accommodated as a worked example.

The following pages provide additional illustrative Plot testing demonstrating how alternative uses could be realised using the following selected Plots:

- ECO1/02: The predominant residential use is illustrated as the alternative commercial use;
- ECO3: The predominant commercial use is illustrated as the alternative residential use;
- EC16: The predominant residential use is illustrated as the alternative hotel use.

▶ Refer to Parameter Plans / Parameter Plan - Proposed Land Use Ground Level Plan (EC.PA.B).

▶ Refer to Parameter Plans / Parameter Plan - Proposed Land Use Upper Levels Plan (EC.PA.B).

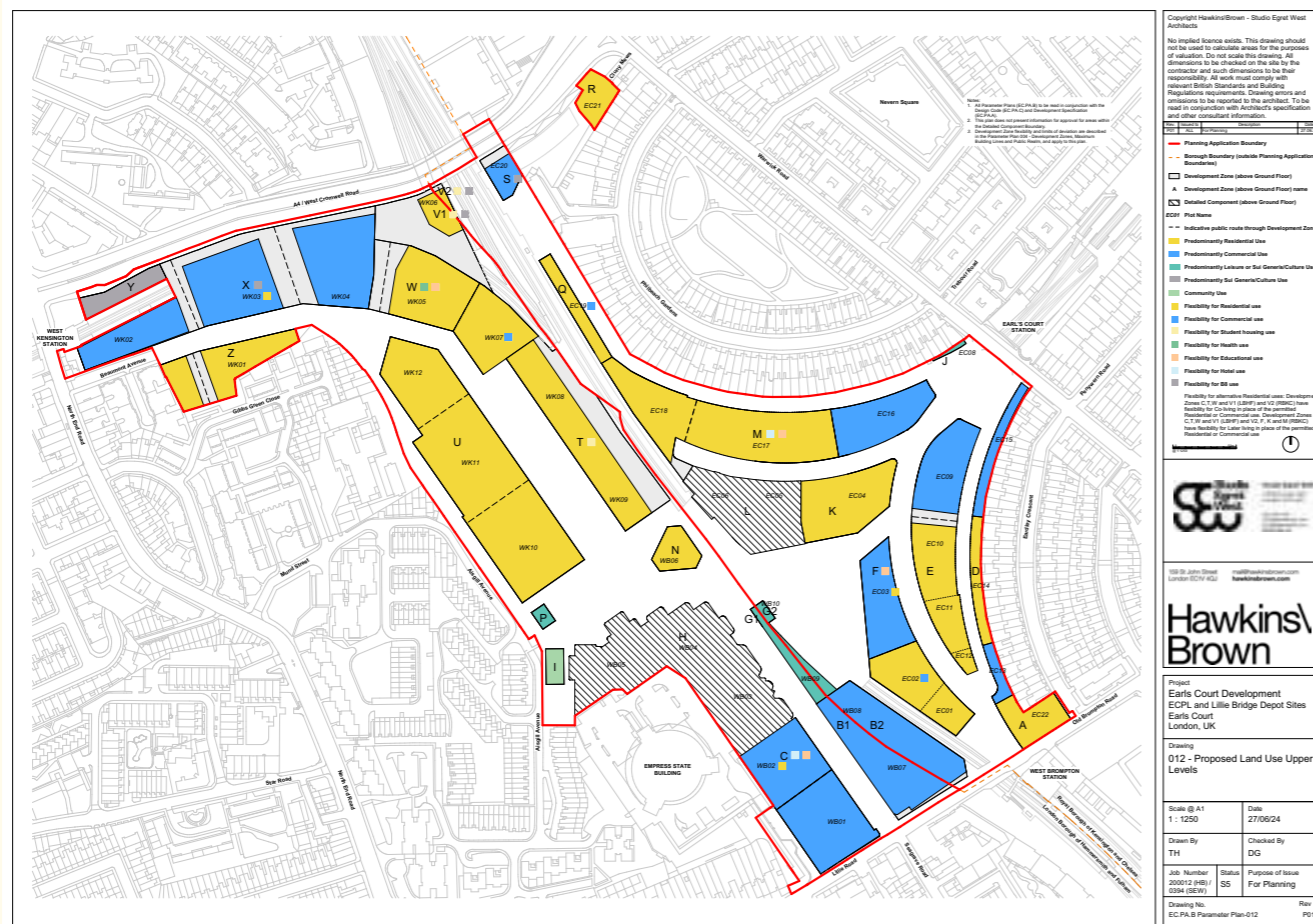

Parameter Plan O12 - Proposed Land Use Upper Levels



Illustrative Masterplan identifying additional illustrative testing on selected Flexible Plots



# 6.11 Flexible Plots

## Table Plot

Plot Code: EC01/EC02  
Typology: Mid-scale block

Illustrative Plot test for predominant alternative commercial use:

Typical Upper Floors - commercial

Ground Floor - mixed-use (retail, café, restaurant, culture and residential)

► Refer to Design Code / West Brompton / Built form / Mansion block / Office block (EC.PA.C).



Illustrative typical floor layout - commercial use

## Alternative illustrative design response



Illustrative eye-level view from the Table Park showing commercial use

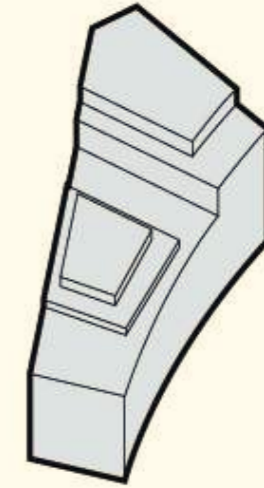

Maximum envelope defined by the Parameter Plans



Illustrative massing overlaid with maximum envelope - commercial use





# 6.11 Flexible Plots

## Table Plot

Plot Code: EC03

Typology: Mid-scale block

Illustrative Plot test for predominant alternative residential use:

Typical Upper Floors - residential

Ground Floor - mixed-use (retail, café, restaurant, culture and residential)

► Refer to Design Code / West Brompton / Built form / Mansion block / Office block (EC.PA.C).



Illustrative typical floor layout - residential use

## Alternative illustrative design response



Illustrative eye-level view across the Table Park showing residential use

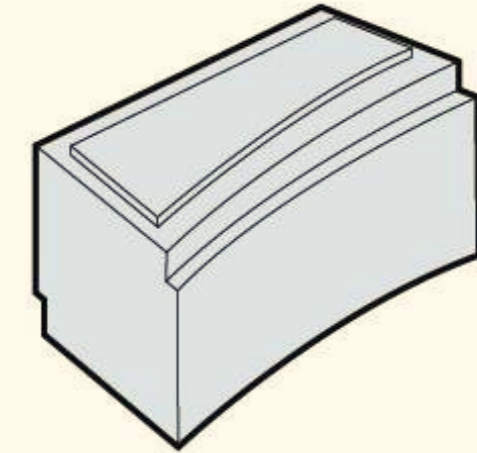

Maximum parameter envelope defined by the Parameter Plans

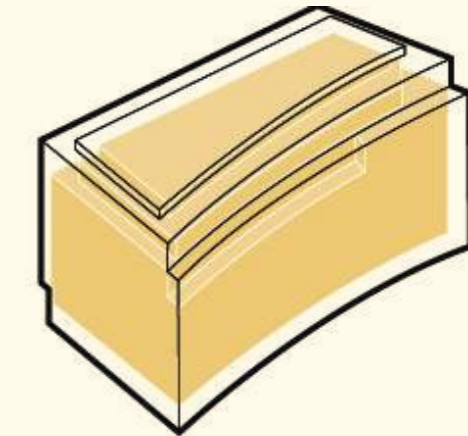

Illustrative massing overlaid with maximum envelope - residential use



# 6.11 Flexible Plots

## Warwick Square Plot

Plot Code: EC16  
Typology: Mid-scale block

Illustrative Plot test for predominant alternative hotel use:

Typical Upper Floors - hotel

Ground Floor - mixed-use (retail, café, restaurant, culture and hotel)

▶ Refer to Design Code / West Brompton / Built form / Mansion block / Mid-scale block (EC.PA.C).



Illustrative typical floor layout - hotel use

## Alternative illustrative design response



Illustrative eye-level view across Warwick Square showing hotel use

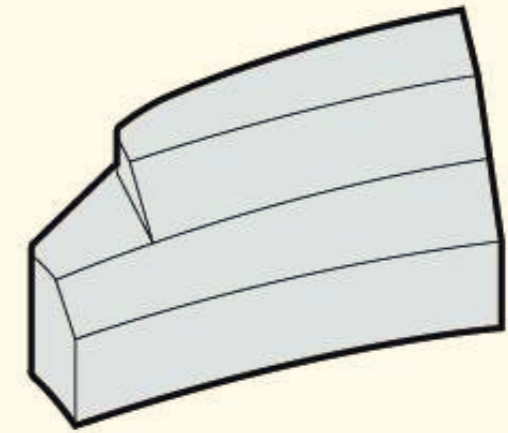

Maximum parameter envelope defined by the Parameter Plans

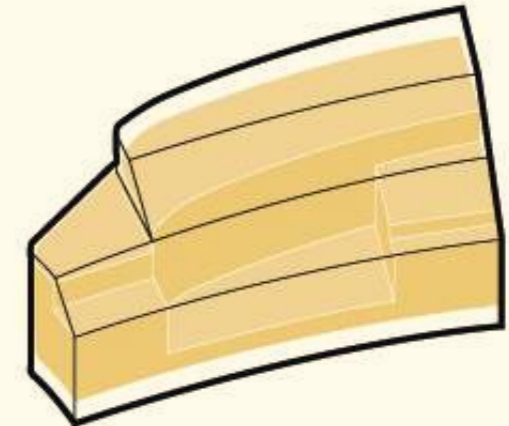

Illustrative massing overlaid with maximum envelope - hotel use



The Illustrative Masterplan could deliver...

A new community facility and nursery

Up to c. 4,000 new homes

including student rooms

c.12,000 jobs

skills and training opportunities

9 hectares

of public realm and green space

Connecting 3 stations

1,000+ new trees

3 cultural venues

Up to 100 new shops, cafés, and restaurants

# 7 Spatial Strategies



# 7.1 Introduction

## Spatial strategies

A set of spatial strategies has been developed to give additional resolution to the principles set out in the Strategic Framework.

This chapter supports the principles of the Control Documents with additional technical and illustrative information. Technical detail has been developed through resolution of the Illustrative Masterplan and is presented to evidence the workability of proposals and policy compliance where relevant.



### Sustainability

Social, economic and environmental sustainability permeates these strategies, underpinning everything and ensuring the Strategic Framework creates a resilient and environmentally responsible place that sets a blueprint for future living.

### Landscape

This section elaborates upon the Strategic Framework to further demonstrate how the Control Documents create a cohesive character by providing design guidelines that shape the landscape of the Exhibition Gardens and public realm as future Plots come forward. This includes public art and lighting.

### Access and Movement

Access into and throughout the Site is a key component of the masterplan. This section elaborates upon the principles in the Strategic Framework and the Control Documents.

### Inclusive design

Creating a place where everyone feels welcome is part of the vision for the Site. This section includes detail on policy and best practice that have shaped the Strategic Framework and Control Documents to create a place that fosters social inclusion.



### Circular economy

This section elaborates on the circular economy approach that has informed the Strategic Framework, and will continue to shape it through the detailed design of the Plots and public realm.

### Utilities

This section sets out how the water, power, digital and other utility strategies have been coordinated with the Strategic Framework.

### Microclimate

This section demonstrates how the built form and open space defined in the Control Documents have been informed by microclimate.

### Health and Safety

This section outlines the health and safety strategies that have been developed to underpin and ensure future deliverability of the masterplan.



## 7.2 Sustainability

### Commitments for environmental wellbeing

ECDC's Sustainable Development Charter, 'Principles for Future Living', sets out the scheme's mission, goals and objectives across the focus areas of social impact, economic inclusion and environmental wellbeing.

The commitments with respect to environmental wellbeing have the biggest impact on the development's spatial and technical strategies.

The commitments made within the Hybrid Planning Applications are consolidated here, but can also be found throughout this chapter, demonstrating how they have informed and shaped the spatial strategies of the Strategic Framework and Illustrative Masterplan.

The aspirations capture The Earls Court Development Company's more ambitious targets. These are aims that will continue to be explored during the detailed design stage of Applications for Reserved Matters Approval.

► *Refer to Sustainability Strategy (EC.PA.21).*



## 7.2 Sustainability

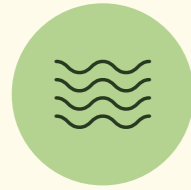

### Water neutral

The commitment is to:

- Irrigate all public realm landscape using rainfall and/or greywater from the Site only.
- Significantly reduce the rainwater runoff from Site compared with existing conditions and improve beyond greenfield rates of runoff. All rainfall to be attenuated on-site, and used or infiltrated to ground to reduce runoff rates from the Site.
- Capture, recycle and re-use water where possible, with 40 days of rainwater and/or greywater storage held on-site available for irrigation.
- Use 100% non-potable water for the Cascades across the year, derived from harvested rainwater and greywater, with 60 days storage to ensure continuity during periods of low rainfall.
- Implement Sustainable Drainage Systems (SuDS) to slow water runoff, infiltrating >60% to the ground in a typical storm event.
- Select climate resilient species in the planting strategy to minimise water demands for irrigation.
- Make buildings water efficient, minimising potable demand through the use of a combination of low flow fittings, rainwater harvesting and where appropriate greywater recycling.

The aspiration is to:

- Limit water usage to 80l/p/d in residential buildings which is 24% better than Building Regulation.
- Consider vacuum flush toilets in office, cultural, food and beverage and retail buildings.
- Develop water strategies further during detail design stages, considering features such as blue roofs etc.



### Beyond net zero

The commitment is to:

- Implement a progressive 5<sup>th</sup> generation 'Ambient Loop' energy network, providing heating and cooling to the Proposed Development and beyond, which will reduce energy consumption and enable site wide CO2 emissions savings of >65% compared to a gas boiler baseline.
- Deliver zero carbon on-site emissions for all buildings, plots and public realm functions in operation, when connected to the 5th generation 'Ambient Loop' energy network.
- Design residential buildings using Passivhaus principles where practicable and where possible, aiming at high environmental performance for residential uses.
- Implement solar PV (or other renewables) on selected, appropriate green roofs (bio-solar roofs) across the Proposed Development, providing at least 280kWp of installed capacity, generating enough energy annually for >65 homes.
- Set a voluntary target carbon budget for all buildings, Plots and Proposed Development components, that aims to go beyond policy to include emissions associated with the operation of public realm and infrastructure.
- Co-locate energy network plant and equipment which minimises embodied carbon, maximises operational efficiency and creates more opportunities for amenity use.
- Reduce the up-front embodied carbon of buildings, targeting <500kgCO<sub>2</sub>/m<sup>2</sup> for domestic and <650kgCO<sub>2</sub>/m<sup>2</sup> for non-domestic uses.

The aspiration is to:

- Reduce the up-front embodied carbon further, delivering ahead of policy expectations.
- Achieve NABERS 5.5\* ratings for offices.
- Create a double benefit by agreeing with both Boroughs that any carbon offsetting funding is used to facilitate retrofit/decarbonisation projects across LBHF and RBKC as first preference.
- Enable connections to the LBHF/RBKC cross-borough energy networks, beyond the application boundary.
- Consolidate plant for shared systems (for example sprinkler systems) across the plots and buildings where practicable/ possible, to minimise embodied carbon, reduce operational energy and costs to tenants and occupiers.

## 7.2 Sustainability



### Delivering clean air

The commitment is to:

- Not use combustion engines to drive the plant within the completed buildings or public realm other than for life safety (e.g. backup generators, which will use sustainable biofuels, until they can be replaced by electric back-up).
- Contain above ground vehicle movements to perimeters of the Proposed Development, maximising car free public realm, safety for pedestrians and with a focus on electric vehicles (or equivalent) and limiting combustion vehicles.
- Repurpose the existing Table and enclose the section of the West London Line on the east and west sides, limiting pollutant egress from cross-site rail traffic.
- Monitor on-site air quality, with data made publicly available for at least 10 years, post completion.
- Provide electric charging points to all parking spaces to promote EV uptake.
- Provide electric car club spaces for 25 vehicles (more than policy) promoting vehicle-sharing for residents and the wider community.

The aspiration is to:

- Achieve at least 10% lower pollutant levels on-site compared to the whole Borough average.
- Implement a range of continuous planting barriers, pollutant-reducing materials and technologies at strategic locations across the Proposed Development aimed at improving air quality, particularly at main access points and alongside the railway to trap pollutants from roads and rail.
- Implement further screening / filtering and /or enclosure of the West London Line to reduce rail pollutant distribution even further.
- Target only electrically powered machinery where practical during the construction phase.
- Encourage off-site consolidation centres to control numbers of vehicles needed on to Site and in surrounding roads. Support sustainable last mile services within and beyond the boundary of the Proposed Development.



### Celebrating nature

The commitment is to:

- Reopen the Site through natural landscapes, with c. 6 hectares (c. 15 acres) of publicly accessible landscape, including the greened or tree-lined roads and crescents.
- Deliver a network of interlinked Exhibition Gardens and spaces containing a diversity of planting strategies to create differing natural landscapes, enabling a wide variety of uses in the public realm.
- Ensure the Site has a Biodiversity Net Gain of 85% which is >75% over the Environment Act requirement of 10% (i.e. policy).
- Plant a minimum of 1,000 new trees of which over 50% will be semi-mature.
- Enhance the existing ecological corridor through the Site.
- Prioritise climate-resilient and native species to create sustainable ecosystems.

The aspiration is to:

- Improve the Urban Greening Factor of the Site beyond the current baseline to >0.4 across the whole Site.





## 7.2 Sustainability



### Healthy living

The commitment is to:

- Select plants to provide wonder and delight; such as species with different flowering seasons.
- Implement a fully accessible and inclusive environment with step-free mobility across the Site.
- Provide comfortable living environments internally and externally for all residents by positively improving the microclimate.
- Create multi-generational public open space, including play space for children of all ages, seating, sensory and contemplative areas for all.
- Create a variety of social interaction spaces from lively, large groups to tranquil and reflective areas.
- Continue to work with the 'Public Realm Inclusion Panel' (PRIP) to interrogate, critique and refine design principles to ensure an inclusive and accessible approach to landscape and buildings.
- Create opportunities for air flow and natural ventilation by optimising the space between buildings.

The aspiration is to:

- Make improvements to wider pedestrian and cycle infrastructure around the Site.

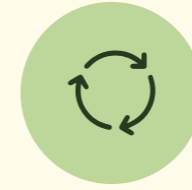

### Circular resource use

The commitment is to:

- Retain buildings and structures which are suited for the requirements of the Site.
- Use materials in the Proposed Development which minimise carbon impacts, targeting 20% of materials that are reused and/or contain recycled content.

The aspiration is to:

- Explore the use of regenerative materials and technologies to enable the circular economy.
- Minimise construction waste by diverting more than 95% from landfill for reuse, recycling or recovery.
- Enable more than 65% of operational waste from all users to be diverted from landfill.



### Certification

The commitment is to:

- Undertake BREEAM Communities pre-assessment for the Proposed Development with a base target of 'Excellent'.
- Undertake HQM Assessment with a base target of HQM 4\* for residential plots and buildings.
- Achieve BREEAM 'Excellent' in office buildings; and a minimum of 'Excellent' in remaining non-domestic uses over 1,000m<sup>2</sup>.
- Achieve WELL Gold in office buildings.

The aspiration is to:

- Achieve an 'Outstanding' rating for the BREEAM Communities pre-assessment for the Proposed Development.
- Achieve HQM 5\* for residential plots and buildings.
- Achieve BREEAM Outstanding and WELL Platinum for office buildings.
- Undertake BREEAM In Use assessments.



## 7.3 Landscape

### A nature-based approach

A holistic nature-based approach has been embedded within the landscape design from the outset to ensure the Proposed Development is biodiverse, comfortable and resilient to climate change.

This section will elaborate upon the Strategic Framework and further demonstrate how the Control Documents create a cohesive character by providing design guidelines that shape the landscape of the Exhibition Gardens and public realm. It will illustrate how the landscape, including public art and lighting, could be implemented throughout the masterplan alongside the future delivery of buildings and development phases.

This section is divided into the following topics, each capturing a different component of the landscape and public realm design:

- Biodiversity
- Planting
- Urban Greening Factor
- Trees
- Soil
- Microclimate
- Water
- Play
- Materiality and Street Furniture
- Art
- Lighting





## 7.3 Landscape | Biodiversity

### A strong north-south ecological corridor

An important ecological corridor enters the Site from the south, extending from Brompton Cemetery along the West London Railway Line. The proposal brings it into the Site and allows it to stretch north.

There is a strategic opportunity for West Brompton Square to act as an important stepping stone between the Brompton Cemetery ecological corridor and the Site. The following strategies are proposed:

- Maximising tree planting in West Brompton Square to extend the cemetery's canopy cover into the Site, creating corridors for birds and bats.
- Fostering habitats along the railway line to create ecological corridors at a lower level.
- Retaining or replacing habitats extending up to the Table Structure through a planted deck connecting the Table Park to Lillie Road (subject to third party approval).
- The Site has a Biodiversity Net Gain of 85% which is >75% over the Environment Act requirement of 10% (i.e. policy)

▶ Refer to Design Code / Sitewide / Landscape / Green/Blue Infrastructure (EC.PA.C).

▶ Refer to Biodiversity Net Gain Assessment (EC.PA.11).



Strategic biodiversity - a strong north-south corridor

Habitat creation principles include:



Connectivity of habitats – helping to support and establish ecological corridors and movement routes



Local diversity – ensuring existing ecosystems are strengthened with appropriate species



Habitat variation – ensuring a wide range of species are supported and building in resilience to climate change

These key strategies mirror the SLOSS (Single Large or Several Small) approach to maximising biodiversity. This combines large areas of green space with small areas of connected habitats. Each of these arrangements provides different biodiversity benefits, ensuring a critical mass of vegetation and habitats are introduced to improve biodiversity, which is connected, local and varied.



## 7.3 Landscape | Planting

### A planting strategy that responds to the Character Areas

Planting typologies are important for delivering the vision and play a key role in defining character, enhancing biodiversity, and supporting year-round activity.

Various planting types will be used within the masterplan to support the distinct characters of the Exhibition Gardens.

Seasonality is a key consideration in the crafting of the planting strategy. The landscape design will be shaped and programmed to deliver a diverse range of experiences that respond to seasonal change and cater for a diverse range of people.

The following pages describe specific planting characters within the Earls Court Development.

▶ Refer to Design Code / Sitewide / Landscape / Green/Blue Infrastructure (EC.PA.C).

▶ Refer to Biodiversity Net Gain Assessment (EC.PA.11).



Sitewide biodiversity - planting characters

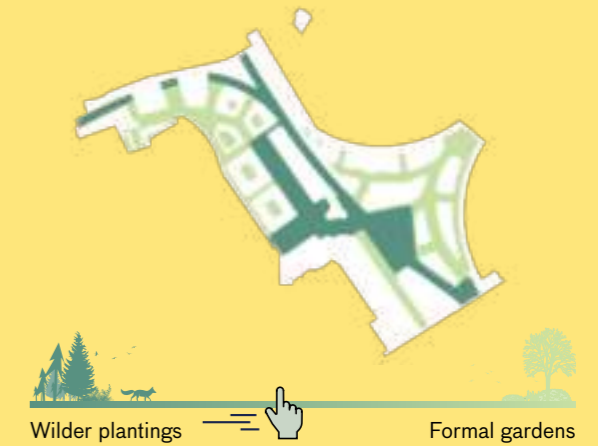

The planting strategy supports the Character Areas

- More formal planting typologies at the Site's edges to respect the existing context.
- Wild, naturalistic planting in the centre, prioritising wildlife habitats along the ecological corridor.



Curated Exhibition Gardens promote biodiversity

- Creating a varied series of gardens with diverse characters and atmospheres.
- Using different planting types suited to microclimates and specific uses across the Site.
- Supporting various species of flora and fauna, increasing biodiversity within the Site.



# 7.3 Landscape | Planting

► Refer to Design Code / Sitewide / Landscape / Green/Blue Infrastructure (EC.PA.C).

## The urban meadow in the Table Park

The urban meadow features a recreational lawn surrounded by wildflower meadows. The central zone of the Table Park will have mounded soil, creating dynamic topography with species-rich grasses and meadows defining clearings of amenity lawn.



## The Bioline, above the West London Railway Line

The Bioline mitigates potential habitat loss by introducing a large area of biodiverse habitat of equal or greater value in the same location. It ensures connectivity with habitats along the rail line to the north and south (including to Brompton Cemetery) and includes host plants and feeding sources for local fauna in the plant mix. The Bioline is subject to agreement with third party land owners.



Recreational lawns and wildflower meadows



Maximising the area of biodiverse habitat to support local wildlife





# 7.3 Landscape | Planting

► Refer to Design Code / Sitewide / Landscape / Green/Blue Infrastructure (EC.PA.C).

## The Cascades at the Table Park

The landscape spills down from the Table Park to Aisgill Gardens through a terraced terrain in the form of rainwater filtration pools. The planting types selected will need to be resilient to both wet and dry seasons, adapting well to different climate conditions.



## The community orchard at Aisgill Gardens

The landscape design of Aisgill Gardens draws inspiration from the Site's market garden history, introducing fruit trees and edible species. The landscape will incorporate play features in the form of standing deadwood and rock piles, ensuring the creation of habitats for invertebrates while providing naturalistic play. Fruit trees are a sensory experience for children while also providing foraging and nesting habitats for birds and bats.



A terraced terrain, where planting will need to be resilient in wet and dry seasons

A seasonal plant mix performing throughout the seasons



## 7.3 Landscape | Planting

► Refer to Design Code / Sitewide / Landscape / Green/Blue Infrastructure (EC.PA.C).

### The ecological stepping stone at West Brompton Square

The planting mix at West Brompton Square maximises native species to provide a range of habitats for birds, insects and mammals. This supports its existing value as an ecological corridor, connecting Brompton Cemetery and railway habitats to the Table Park. Its location at the threshold of the masterplan creates an opportunity to use planting to reduce the impact of air pollutants. The landscape design will be used to create a vegetation barrier as a passive filtering system.



### The Flower Amphitheatre at Warwick Square

The planting palette on Warwick Square takes inspiration from the Chelsea Flower Show, celebrating nature through sustainable gardening practices that promote biodiversity. By prioritising native flowering species, the square will support pollinators, providing food and habitat throughout the year and across the changing seasons. The planting scheme prioritises a plant mix that can perform throughout all seasons, with species that blossom at different times of the year and have interesting seedheads during the winter period. Variety of colours and types ensures an aesthetic appeal and an active, biodiverse habitat year round.



Maximising native species to support the ecological connection

Maximising a variety of colours and types of planting that blossom throughout the year



# 7.3 Landscape | Planting

► Refer to Design Code / Sitewide / Landscape / Green/Blue Infrastructure (EC.PA.C).

## Post-industrial remediation gardens at Lillie Sidings Square

The planting palette at Lillie Sidings Square mirrors the industrial character of the Site, featuring species capable of thriving in rugged conditions and enduring high user activity. As this area is on terra firma, the planting list emphasises semi-mature tree species with ample canopy clearance, maintaining clear sightlines along the north-south boulevard.



## Climate-resilient streets

The streetscape planting strategy incorporates tree varieties with ample canopy clearance, allowing unobstructed views along the boulevards and crescents. Flowering trees are intentionally included to enhance the aesthetics of pedestrian pathways and promote biodiversity. Rain gardens feature species that can adapt to varying humidity levels, ensuring a diverse ecosystem within the streets.



Images illustrating the character and design language of Lillie Sidings Square

Images illustrating the character and design language of climate-resilient streets





## 7.3 Landscape | Urban Greening Factor

The Illustrative Masterplan takes a holistic approach to urban greening, delivering a significant amount of green infrastructure across the Site.

The Illustrative Masterplan achieves an Urban Greening Factor (UGF) score to meet the policy requirement of 0.4, while also fostering biodiversity.

UGF has been tested for two scenarios. The first scenario illustrates the maximum Plot extent as shown on the parameter plans and the second scenario illustrates the Illustrative Masterplan layouts. Both scenarios achieve a UGF score of 0.4, as per policy requirement. The score is also achieved under the 'Early Phases' phasing scenario.

This analysis relates to the Illustrative Masterplan and would be reviewed with Application for Reserved Matters Approval (RMA) where relevant, to explore other opportunities and ensure the long-term policy requirement for the development is achieved.

*The UGF is determined by calculating the area of each surface within the Site boundary. Different surface types are assigned scores, with natural vegetation scoring highest and impermeable hard surfaces scoring lowest. Trees contribute to the UGF score based on their canopy dimensions.*



Illustrative Urban Greening Factor diagram

▶ Refer to Design Code / Sitewide / Landscape / Green/Blue Infrastructure (EC.PA.C).

▶ Refer to Urban Greening Factor Plan (EC.PA.10).



## 7.3 Landscape | Roofs

### Publicly accessible roof terraces

There are several opportunities for public access to the upper areas and roof terraces of buildings in the Illustrative Masterplan in line with the intent of London Plan Policy D9 Part 4. These spaces would offer elevated views of the Exhibition Garden landscapes, as well as views towards the Thames and the London skyline.

Opportunities for public roof terraces are mostly located in larger commercial buildings with cultural venues at the ground level. Terraces would likely include landscaped and planted areas to maximise green roofs. Access could be either via a dedicated lift core or managed access through the office building. Large terraces could be served by food and beverage units and smaller culture venues hosting public and private events. Details, including management and access provisions, will form part of future Applications for Reserved Matters Approval (RMAs).



Indicative accessible roof terraces diagram



Rooftop of commercial / cultural building with views to the City



Rooftop of commercial building overlooking Warwick Square

## 7.3 Landscape | Trees

### Tree planting strategy

Tree planting has been intensified across the Illustrative Masterplan as it plays an important role in developing habitats, creating comfortable microclimates, improving air quality, reducing surface water runoff, reducing air temperatures and capturing carbon.

The following principles have been considered when developing the tree planting strategy contained in the Design Code:

- Each landscape Character Area features a variety of tree sizes, forms, and species for diverse colours, forms, and seasonal interest, ensuring resilience against pests and climate change.
- Trees are planted at semi-mature sizes for instant impact and ecological connections. The Urban Greening Factor calculation considers small, medium, and large trees, as illustrated on this page.
- Existing habitats and trees are retained and enhanced where possible. Dead wood is kept on-site to create habitats for invertebrates, providing food for small mammals and birds, and offering play and seating opportunities.

► Refer to Design Code / Sitewide / Landscape / Planting / Trees (EC.PA.C).



Illustrative proposed tree diagram reflecting likely scenario of number of trees, location, variation, size and layout.



## 7.3 Landscape | Trees

### Tree retention strategy

The majority of existing trees within the Site and along its boundaries are retained and integrated into the sitewide tree planting strategy demonstrated within the Illustrative Masterplan.

Some trees will be removed to facilitate the implementation of the routes and interfaces at the edges. These are primarily located in private areas of the Site, currently inaccessible to the public. The approach to existing trees has been as follows:

- Over 1,000 new trees will be planted.
- Existing trees within the current public realm are given priority for retention where feasible.
- Factors such as tree health, visual importance, size, and amenity value are taken into account when deciding whether to retain or remove trees.
- Any tree identified for removal will be repurposed within the design whenever possible, serving as play elements, seating, ecological features, or wood chip mulch.
- Retained trees will be safeguarded during construction in accordance with BS 5837.

► Refer to *Arboricultural Impact Assessment (EC.PA.09)*.

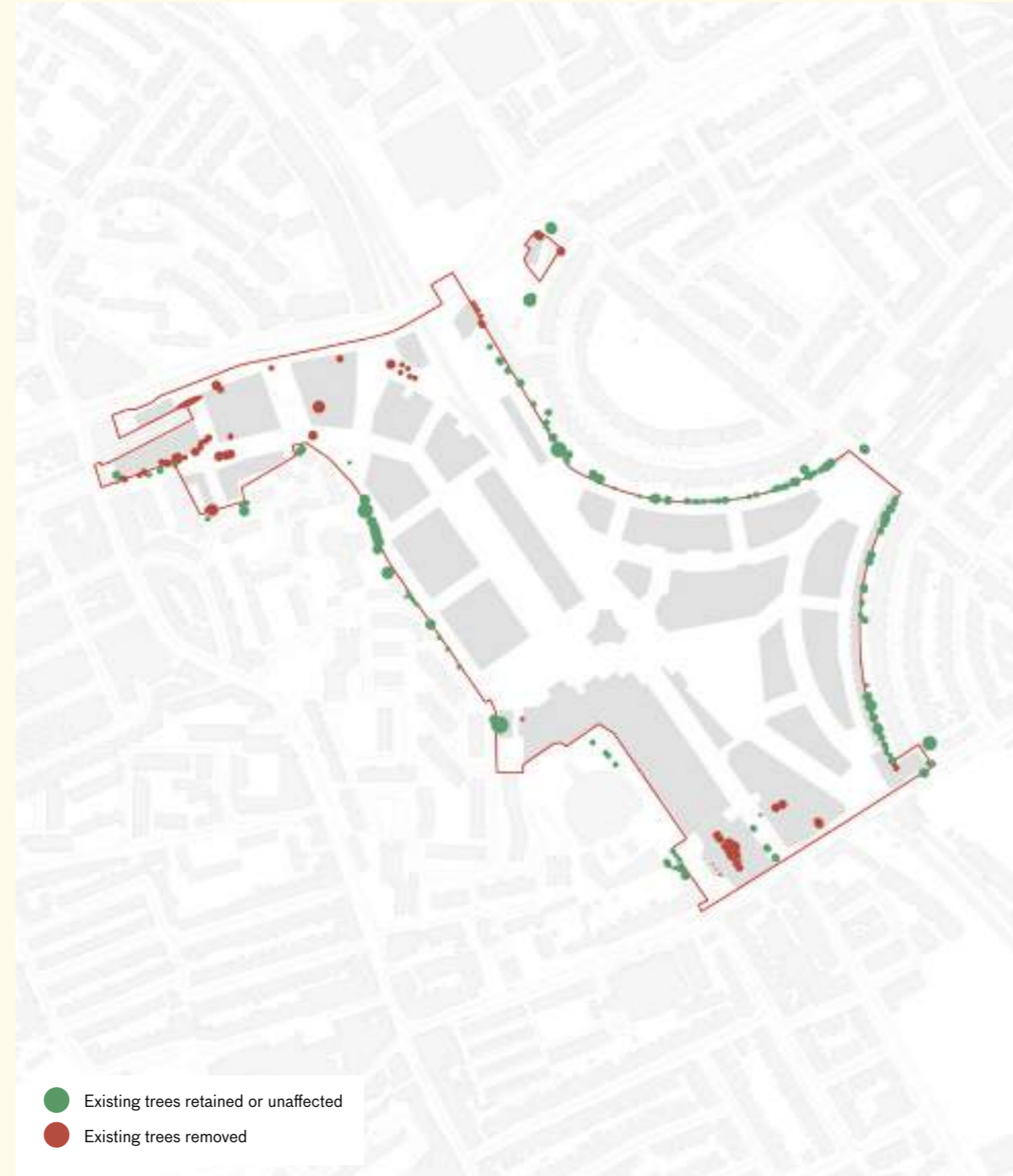

Illustrative tree retention diagram showing location of existing trees



Removed trees reused for play



Removed trees reused for seating



Removed trees reused for mulch



# 7.3 Landscape | Soil

## Soil strategy

The proposed soil strategy ensures adequate depth for tree and plant growth whilst promoting carbon sequestration within the masterplan.

The following approaches are considered as part of the soil strategy:

- Establish minimum soil depths and drainage considering historic or proposed man-made structures.
- Soil strategy details conditions and soil build-ups across the Site.
- Minimum soil depth for large tree planting is 1.2m, with potential for greater depth in many locations.
- Structural slabs designed to accommodate tree planting, soil depths, emergency vehicles, and play equipment.
- Drainage layers included in build-up assumptions to ensure proper tree pit drainage.



Soil depth strategy diagram

Grasses & perennials	Small shrubs	Large shrubs and small trees 4-6 m.	Large trees 8-16 m.
30 cm	35 cm	60 cm	120 cm
350 kg/m <sup>2</sup>	440 kg/m <sup>2</sup>	1000 kg/m <sup>2</sup>	1900 kg/m <sup>2</sup>
min. 30kg/m <sup>2</sup> soil planting	min. 30 kg/m <sup>2</sup> soil planting	min. 250 kg/m <sup>2</sup> soil planting	min. 400 kg/m <sup>2</sup> soil planting

Planting types soil build-ups

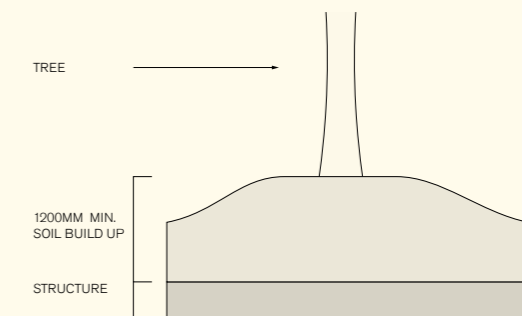

Mounded soil build-up for large tree

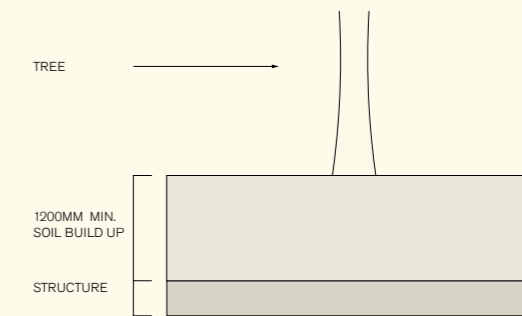

Soil build-up with no mounding for large tree

# 7.3 Landscape | Microclimate

## Microclimate strategy

Nature-based solutions can improve air quality, reduce wind speeds, foster comfortable public realm and encourage year-round use for outdoor activity.

The comfort of people, whether strolling, sitting or standing, can be achieved through nature-based design solutions, which is described in the Control Documents. A favourable microclimate can be created through landscape design that considers several key issues, including the selection of climate-resilient plant and tree species, the maturity of the vegetation specified, the location of the planting, and seasonal change. Additionally, the following have been considered in relation to microclimate:

- Recreational space uses are strategically located based on sunlight testing, ensuring active areas receive optimal sunlight.
- Appropriate tree selection ensures shade and breeze mitigate hot summer weather, while allowing sunlight penetration in winter.
- Tree clusters act as windbreaks, providing shelter and comfortable seating areas in the public realm.
- Nature-based design at key thresholds along busy roads helps mitigate air and noise pollution.
- Using a mix of deciduous and evergreen trees with diverse leaves to help reduce air pollution throughout the year, not just by physically separating from the pollutant source.

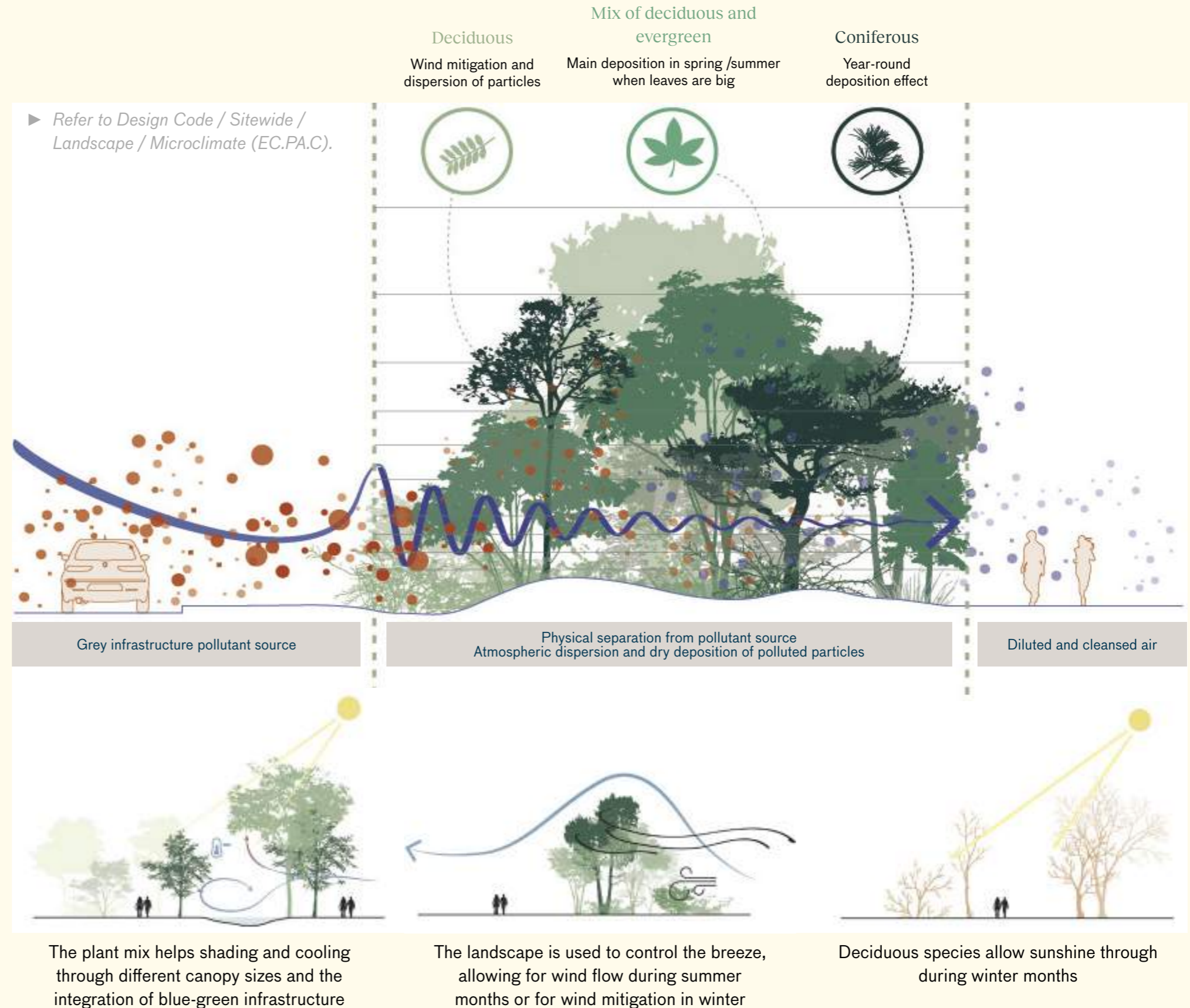



## 7.3 Landscape | Water

### Sustainable water management strategy

Harnessing water's immense potential for integrating play, biodiversity and sustainability is a fundamental way to support health and wellbeing, reducing the urban heat island effect in London and the wider area.

The sustainable and nature-based water management approach in the Illustrative Masterplan is defined by the following principles:



Water creates social value and brings people together

Nature-based rainwater management will not only deliver a utility value, but also create important social value.

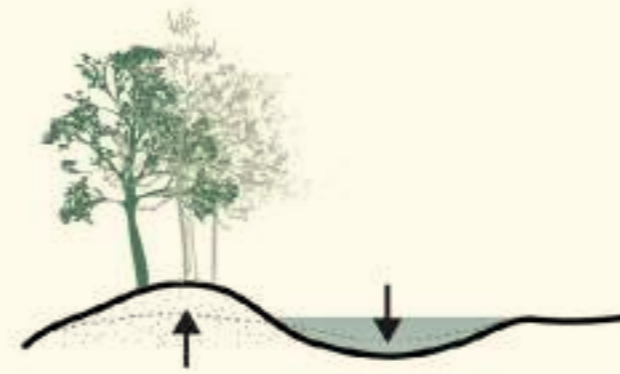

Level changes can be harnessed to move water

By using the level changes in the landscape rainwater can be conveyed and stored through gravity.



Water cools public spaces and makes them more enjoyable

Water bodies and water features naturally cool the public realm through water evaporation, helping to create comfortable micro-climates.



Water increases biodiversity and habitats

Open water features are hotspots for biodiversity, attracting invertebrates, birds and bats. Planting as part of Sustainable Drainage System (SuDS) also create habitats in their own right.



Adaptable planting supports a range of wet and dry conditions

Plant species selection for SuDS features will be resilient and adaptable to both wet and dry seasons.

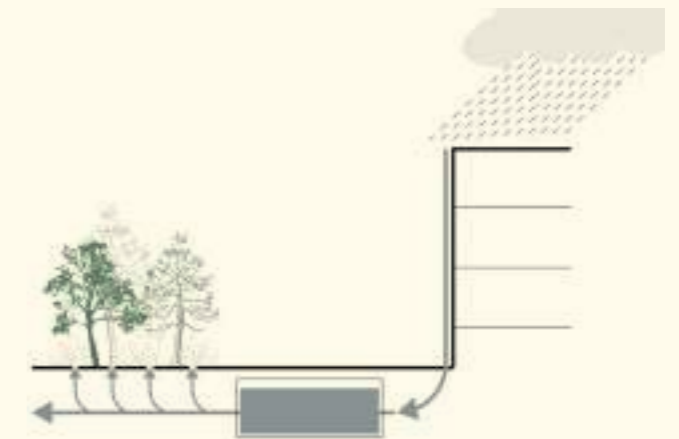

Water can be collected for irrigation

Water will be collected on Site through tanks, bowsers and crate systems that can be used for irrigation of planting.

► Refer to *Integrated Water Management Strategy (EC.PA.41)*.



## 7.3 Landscape | Water

### Sustainable Drainage Systems

The location of above ground Sustainable Drainage Systems (SuDS) features is influenced by proposed Site levels and underground infrastructure.

The following considerations have informed the approach to SuDS features:

- SuDS features are positioned above ground level for potential infiltration into the soil below.
- Their placement above slabs does not restrict SuDS features; they function as self-contained systems that slow, filter, transpire, and convey surface water runoff towards soakaway areas.
- A mix of dry and wet features includes rain gardens and detention ponds. Retention ponds will remain wet year-round to enable people to experience water and to serve as wet habitats, which are rare in London.
- Water collection tanks and bowsers are strategically located across the Site to make water circularity visible to residents and visitors.

The following pages describe the proposed strategies in more detail within specific areas of the public realm.

► Refer to *Integrated Water Management Strategy (EC.PA.41)*.



SuDS strategy diagram

NOTE: Illustrations as defined in the World Bank's 'A Catalogue of Nature Based Solutions for Urban Resilience', available [here](#).

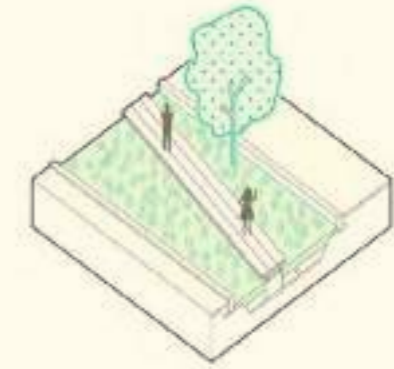

### Bioswales and rain gardens

These are shallow, densely vegetated ground depressions, which collect stormwater from adjacent impervious surfaces. During storms, they become flooded and facilitate ground infiltration and cleaning of stormwater.

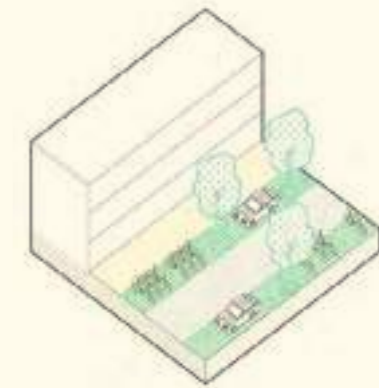

### Permeable pavements

These are especially effective during less intense storms for reducing surface runoff. They infiltrate, treat, and store rainwater and reduce runoff by allowing rain water to naturally infiltrate into the ground below.

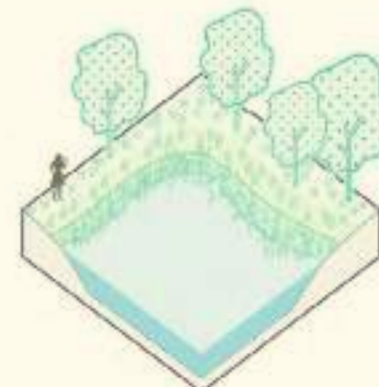

### Retention ponds

These are bioretention areas characterised by a permanent body of water and vegetated edges. Unlike detention ponds, they are permanently filled with water. Retention ponds collect stormwater from the surrounding areas; add storage capacity and ease the pressure on the surface water treatment and sewerage systems.





# 7.3 Landscape | Water

## Bioswales at the crescents

Bioswales located along West Brompton and Warwick Crescents store excess rainwater during heavy rainfall and release it gradually into the drainage system. These features help to accentuate the geometry of the crescents.



Location plan: Warwick and West Brompton Crescent



View of West Brompton Crescent showing bioswales integrated in the landscape

Bioswales are employed in the eastern section where surface water cannot naturally infiltrate in all locations due to underlying rail tunnels.

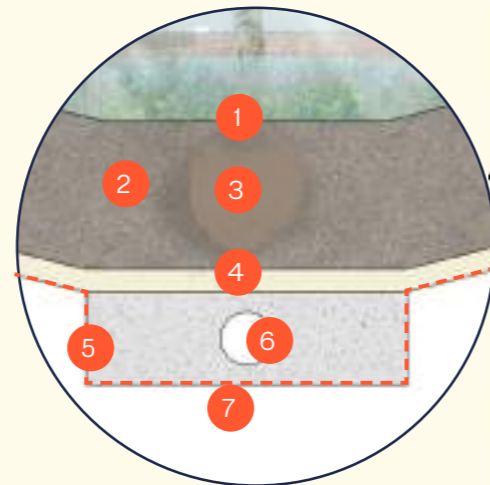

- 1. 0.5m depth to swale planting
- 2. 1.2m soil depth for large trees
- 3. Tree species tolerant of changing moisture levels
- 4. 150mm filter medium
- 5. Impermeable barrier to prevent water infiltration
- 6. Perforated pipe to move water across Site
- 7. Void zone between transfer structures and bioswale build up
- 8. Transfer structure of District Line tunnel





## 7.3 Landscape | Water

### Aisgill Gardens retention ponds

Retention ponds located on terra firma help maintain a consistent water level and can store excess runoff, minimising the requirement for underground attenuation tanks. They function as playful features that support the public realm aspirations for Aisgill Gardens to be a community space.

Storing water above ground through retention ponds has the benefit of providing ecological habitats and visual connection to water.



Location plan: Aisgill Gardens



View of Aisgill Gardens showing retention ponds integrated within the landscape

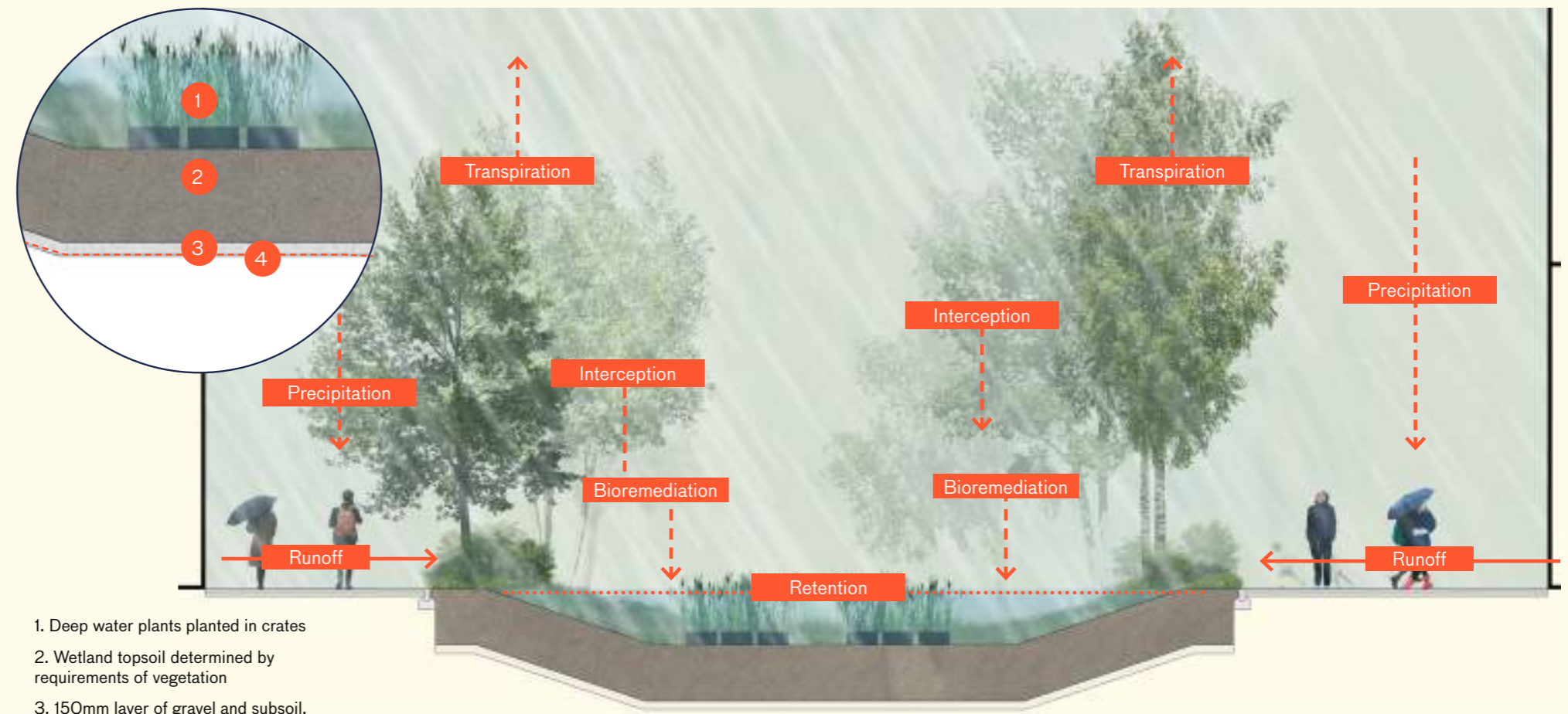

# 7.3 Landscape | Water

## Lillie Sidings Square bioretention strips

Planted bioretention strips located on Lillie Sidings Square help to store and filter surface water runoff. They form an integral part of the public realm and enhance the industrial character.

The post-industrial character of Lillie Sidings Square creates an opportunity to introduce large-scale water collection towers, gathering runoff from buildings for irrigation purposes.



Location plan, Lillie Sidings Square



View of Lillie Sidings Square showing bioretention strips integrated within the landscape

1. Bioremediating plants such as Typha sp. , Phragmites australis and Iris sp.
2. Wetland topsoil determined by requirements of vegetation
3. 150mm layer of gravel and subsoil
4. Pond liner

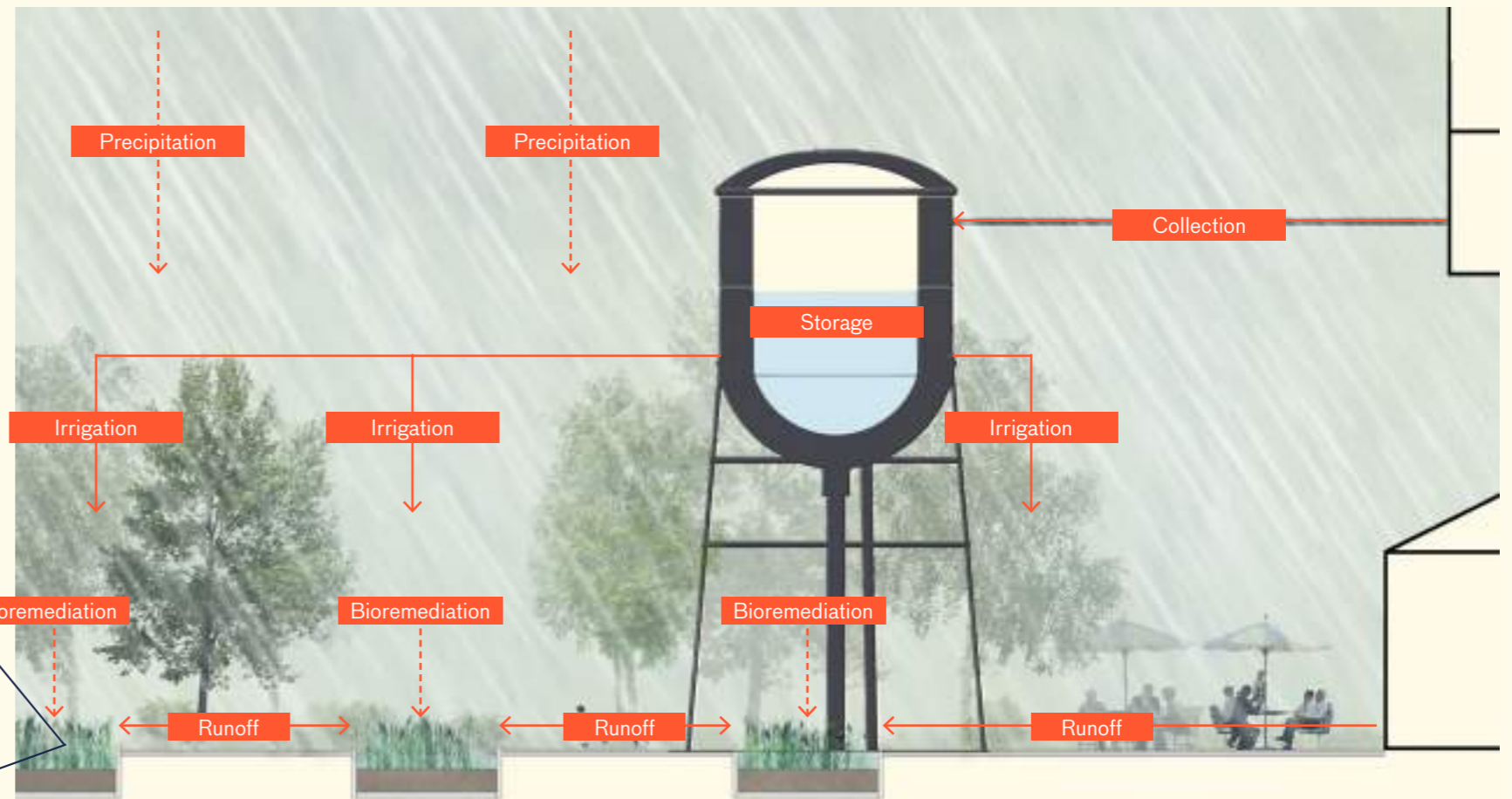
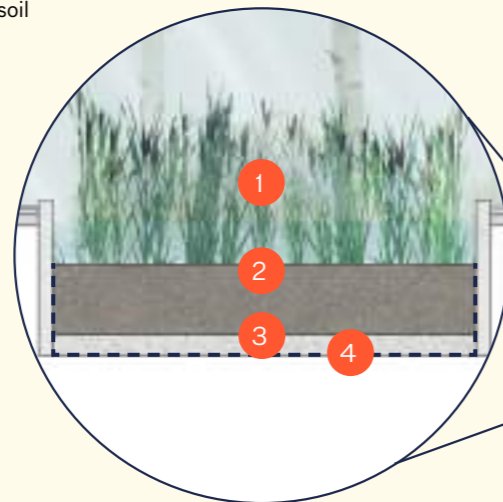



## 7.3 Landscape | Water

### The Cascades

The Cascades becomes a place to interact with water whilst also embodying the approach of water circularity and climate adaptation.

Within the Illustrative Masterplan, the Cascades will use 100% non-potable water across the year, derived from harvested rainwater and greywater. Design considerations include:

- Rainwater initially collects on building and ground surfaces. Gravity channels runoff to holding and filtration tanks below ground.
- Filtered water is pumped back up for use in water features that have no direct human interaction.
- Some water passes through further filters for safe use in play features.
- Water used in play features undergoes recycling and filtration.
- Tank sizes are designed to store 60 days' worth of water, ensuring the functionality of the Cascades during drought periods.



Location plan: The Cascades



View of the Cascades showing integration of water within the landscape

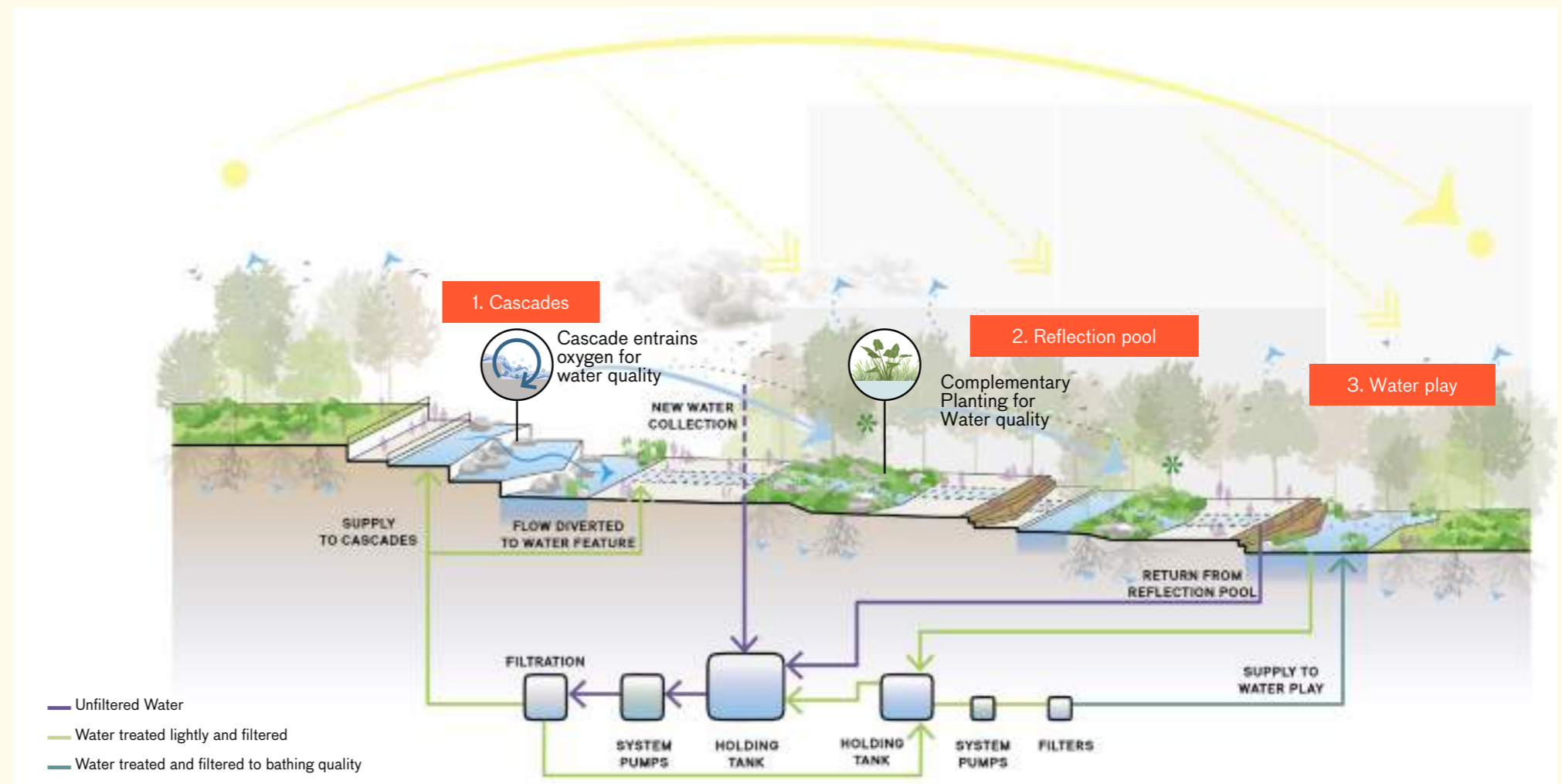

Diagram illustrating water systems utilised within the Cascades



## 7.3 Landscape | Play

### Achieving a playful public realm for all ages and needs

The play strategy intends to meet the play needs of all children and young people. It will do this by providing playable spaces, dedicated play spaces and safe routes between them.

Earls Court will create a welcoming, inclusive and supportive place for resident children and young people, as well as those in the local area. It will be somewhere for children and young people to enjoy and feel safe whilst playing and socialising. The play strategy is fully compliant with Section S4 of the London Plan and embraces the principles of the Good Growth Design Making London Child Friendly Report as follows:

- Enabling children to access play spaces safely and independently.
- Distributing play throughout the open spaces including risky play and exploration.
- Forming an integral part of the surrounding neighbourhood and encouraging children and young people to enter Earls Court.
- Play will not be segregated by housing tenure and will be provided for all age groups and needs.
- The spaces will be overlooked and will incorporate trees and/or other forms of greenery.

▶ Refer to Design Code / Sitewide / Landscape / Play (EC.PA.C).



Play strategy diagram

Play typologies have been influenced by the following principles:



1. Play will be stimulating, interesting and inviting



2. Play will be everywhere: convenient and accessible



3. Play will be safe, healthy and nature-based

# 7.3 Landscape | Play

► Refer to Design Code / Sitewide / Landscape / Play (EC.PA.C).

## Typologies embedded within the Illustrative Masterplan



Playful streets

Vehicle-free streetscapes will become lively spaces for children by incorporating informal play areas within green infrastructure and designing pavements that encourage spontaneous play.



Dedicated playground

Destination playgrounds will be thoughtfully designed to integrate inclusive and accessible elements that invite children of all abilities to play and learn together. These will support parents, carers and different family structures.



Water play

Water features will be spaces where children can play, naturally cool in the summer but also available to play in during the colder months. Water will be incorporated into level changes.



Courtyard play

Courtyards will provide contained play space for younger children close to home. Consideration will be given for how children can reach these spaces, play independently and for how play is balanced with the needs of other residents.



Sports play

Clearings in the Table Park will be provided within the landscape to create space for informal sports, play and recreation. Support for this type of play will be part of a management strategy so that children and young people are able to play games in these areas.



Risky play

Level changes in play environments, such as elevated steps or climbing structures, will provide opportunities for children to engage in risky play. Play equipment will offer a broad range of experiences at different levels so that children are able to test through graduated risk, according to their ages and abilities.



Nature play

Nature trails will trigger children's creativity and curiosity, allowing children to manipulate their surroundings to create engaging play opportunities. Opportunities to climb trees, discover sensory planting experiences, get hands dirty and experience tactile materials such as sand and water will be integrated within play designs.



Flexible hard surfaces

Informal stepping stones and log bridges through rain gardens will ensure opportunities for play and physical activity along every-day routes, embedding play within daily lives of children.



## 7.3 Landscape | Play

### PRIP impact on play strategy

The Public Realm Inclusivity Panel (PRIP) has extensively explored ideas about play at Earls Court, both in sessions dedicated to play and in more general discussions.

The PRIP sessions covering play and mobility were structured in the following way:

- Session 02 - Parks and open space: Used collage to explore what makes a good park or open space.
- Session 03 - Aisgill Gardens: Explored the idea of play, recreation and sport through a collage exercise of Aisgill Gardens.
- Session 04 - Aisgill Gardens and Table Park: The PRIP continued to discuss play in relation to Aisgill Gardens and the Table Park.
- Session 05 - Masterplan and Aisgill Gardens: Reviewed the masterplan and initial designs for Aisgill Gardens including mobility and play.
- Session 06 - Warwick Apron: Explored access, movement, and the different activities that could happen at Warwick Road Apron.
- Session 10 - Movement: Explored movement across the Table Park and the wider masterplan, including how play can be accommodated within the movement strategy.
- Session 14 - The Cascades: Reviewed the initial design of the Cascades, including how play is incorporated into the level change and water features.
- Session 16 - Masterplan review: Reviewed the masterplan including mobility and play.
- Session 17 - Access and Mobility: Reviewed Access and Movement section of the Design Code.
- Session 18 - The Cascades & Local Routes: Second review of design proposals for the Cascades and mobility along six local routes.

PRIP suggestions as a result of these sessions included:

- Spaces should be green, with water and integrated play.
- Allow for risky play and exploration.
- Provide places to cycle or skateboard.
- Create sensory activities.
- Integrate play into level change, for example, gradual slopes that are good for skating.
- Allow for sports.
- Some people enjoy places where they can sit and observe others, for example watching sports and children playing.



Session 03: Aisgill Gardens collage exercise



Session 10: Movement collage exercise



Session 11: Elephant Park visit



## 7.3 Landscape | Play

### Playspace scenarios

Playspace provision in the Illustrative Masterplan has been evaluated in anticipation of potential development scenarios, safeguarded, and strategically allocated within the broader masterplan.

To demonstrate the versatility of the Proposed Development, various play scenarios have undergone testing, all guided by the principles outlined on the preceding page.

The following play scenarios have been assessed:

- Minimum scenario: This scenario tests the minimum number of homes that could be delivered within the framework if all Flexible Plots were to be commercial.
- Maximum scenario: This scenario tests the maximum number of homes that could be delivered within the framework if all Flexible Plots were to be residential.
- Illustrative scenario: This scenario tests the most realistic blend of commercial and residential across the Site.

► Refer to Design Code / Sitewide / Landscape / Play (EC.PA.C).



Illustrative Masterplan scenario play requirement plan



Minimum scenario play requirement plan



Maximum scenario play requirement plan



Sun hours on ground (BRE compliance, 21st March)





## 7.3 Landscape | Materiality

### Paving and materiality

The paving and materiality strategy balances overall coherence across the masterplan with the individual expression of each Character Area and its local context.

The strategy is tailored to different types of spaces. The following principles inform material selection in the Control Documents:

- Paving materials prioritise people-first design, comfort and safety.
- Clear differentiation of materiality between footways, bike lanes, and roads or shared surfaces aids wayfinding.
- Hardscape materials prioritise accessibility, with a focus on wheelchair-friendly, firm, and slip-resistant options suitable for all weather conditions.
- Materials serve as a background element, with the landscape's focus primarily on planting and natural features.

► Refer to Design Code / Sitewide / Landscape / Materiality (EC.PA.C).



Materials strategy diagram



More formal materials are employed along streets, crescents, and boulevards to complement their structured layout



Natural, informal materials are used in prominent public areas like the Table Park and Lillie Sidings



Accent materials and furniture are incorporated at thresholds to enhance local character and blend with the surrounding context

# 7.3 Landscape | Street Furniture

## Street furniture

Street furniture will be selected to ensure a familiar design language within a particular Character Area, and a coherent appearance across the masterplan overall.

- Street furniture (seating, bollards, bins) will reflect the character of each landscape zone, supporting the Exhibition Gardens concept.
- Furniture selection will respond to the existing characteristics of interfacing streets and public realm areas, integrating the Site into the wider neighbourhood and avoiding a clear distinction at Site entrances.
- Accessibility and inclusivity are central, with furniture designed for diverse needs (e.g. back and armrests, varied seating depths and heights, open bases).
- Benches will be placed in public spaces and along pedestrian routes for resting, people-watching, and socialising.
- A variety of seating options will accommodate different group sizes or individuals.
- Seating arrangements will support a variety of users including wheelchair users.
- Cycle stands will be located in well-surveilled areas along key routes for convenience.

► Refer to Design Code / Sitewide / Landscape / Street Furniture (EC.PA.C).



Fixed individual seating

Fixed individual seating along key routes offers frequent opportunities to sit and pause, catering to those who prefer privacy and need regular rest.



Fixed social seating

Fixed seating arranged in corners, concave shapes, or small “rooms” allows larger groups to sit together and encourages social interaction among strangers. Placing social seating in key destinations with heavy pedestrian traffic can create a lively atmosphere.



Flexible seating: social and individual

Flexible seating arrangements are ideal for larger pedestrian spaces with diverse activities. These configurations allow people to move and adjust seating to suit their needs. It can accommodate groups or individuals, provides choice of sun or shade, and of preferred viewpoints for observing activities.



Example of fixed individual seating



Example of fixed social seating



Example of flexible seating



# 7.3 Landscape | Art

## Sitewide art strategy

A dynamic and evolving art strategy will form an important part of ensuring the Earls Court Development is a cultural destination within London.

The Earls Court Development art strategy sets out a framework for how to work collaboratively to create art that will reinforce a sense of place and tell the story of this unique part of London and its communities.

The following approach could be used to deliver an art programme across the Earls Court Development:

- Establish the brief and location for an art installation.
- One or more artists longlisted for their proven ability to bring real social and cultural value through a community co-creation process whilst also demonstrating experience in the making and delivery of public art work.
- Artist shortlists (or single artist) could be selected by the steering group to develop an art co-creation strategy.
- An artist or group of artists could be selected to take forward an art project(s) for delivery.

► Refer to Design Code / Sitewide / Landscape / Public Art (EC.P.A.C).

Key principles that would add value to the art strategy:

- The design and delivery of artwork(s) should be considered alongside the development of the landscape design to ensure that installations are successfully woven into the public realm
- Temporary art works should consider the phasing strategy and explore opportunities to enrich customer experience and help to establish the place early on
- Art should be considered alongside the development of the wayfinding strategy to explore opportunities to create landmarks that help people to create 'mental maps' of the place

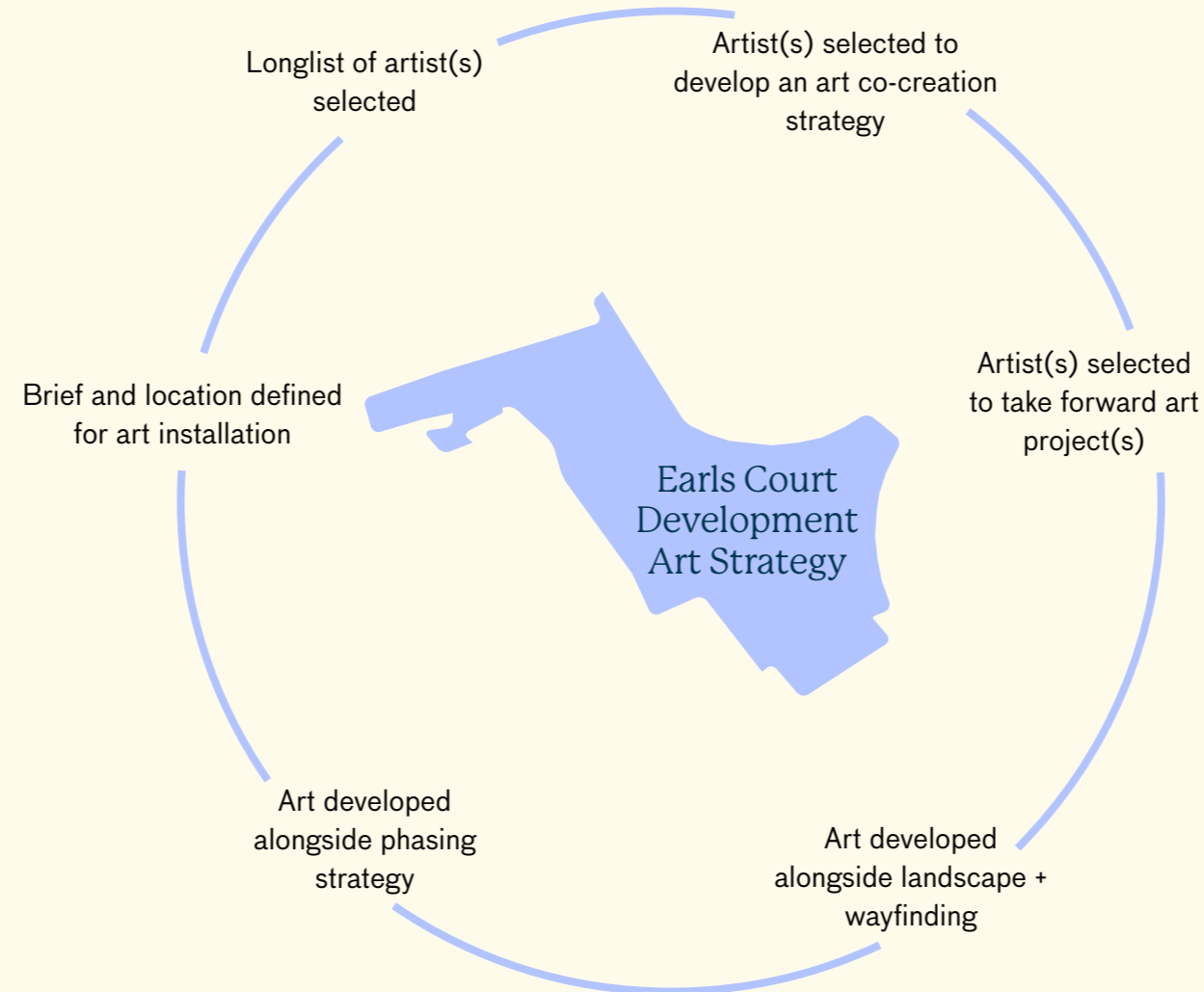

Diagram illustrating the art strategy process

## Art at Earls Court today



Temporary artwork on Warwick Road Apron



Artist in Residence at the Community Hub



Artwork on the site hoardings



The transformation of Empress Place terraces into Empress Studios, a collection of 46 artist studios



## 7.3 Landscape | Lighting

### Sitewide lighting strategy and characters

Lighting will play a crucial role in highlighting and celebrating each of the place pillars after dark.

The following considerations have informed the lighting strategy for the Site:

- Providing layers of light to support a variety of functions, from quiet residential streets to busy cultural venues.
- Supporting after dark use of the public realm by enhancing the night time character of the spaces.
- Creating a perceivably safe environment through hierarchy, legibility of highlight of architectural and landscape interventions.
- Providing a lit atmospheres which changes over time to meet varying demands of spaces and users throughout the night and across seasons.
- Restricting light pollution and the impacts of artificial light on ecosystems and neighbours; controlling and minimising light levels and the impact on wildlife and adjacent properties.
- Tailoring varying lighting characteristics to the functions and users of various spaces across the masterplan.
- Identifying a variety of luminaires, locations, mounting types, and approaches to the control of the lighting to create suitable atmospheres for each Character Area and route typology.



Commercial Streets - Illustrative evening view of West Kensington Boulevard



Community Green - Illustrative evening view of Aisgill Gardens



Lillie Sidings Square - Illustration of how lighting design can bring the square and activity to life after dark



Commercial Streets - Illustrative evening view of West Brompton Crescent



Commercial Streets - Illustrative evening view of Empress Place Boulevard

► Refer to Design Code / Sitewide / Landscape / Lighting (EC.PA.C) and Design and Access Statement Volume 1: Outline Component / Appendix (EC.PA.08).



## 7.4 Access and Movement

### Introduction

The Strategic Framework has adopted a 'people first' approach, seeking to prioritise pedestrians and active travel.

Access into and throughout the Site is a key component of the masterplan, both in operational terms but also in creating attractive urban spaces that align with Transport for London's (TfL) Healthy Streets Approach, which is a human-centred framework for embedding public health in transport, public realm and planning. It is supported by the Mayor of London and Greater London Authority (GLA) as set out in 'A City for All Londoners' and 'Healthy Streets for London.'

This section elaborates upon the principles in the Strategic Framework and the Control Documents. This includes:

- Public transport
- Pedestrian movement
- Accessible public realm
- Cycling
- Deliveries and Servicing

► *Refer to the Transport Assessment (EC.PA.13).*





## 7.4 Access and Movement

### Priorities for access and movement and inclusive design

The Transport Assessment sets out the priorities that underpin the approach to access and movement, inclusive design, and access for all, around the development.

Emerging from conversations with the public during consultation and through engagement with the Public Realm Inclusivity Panel (PRIP), these priorities set the scene for the following pages which detail access arrangements around the Site for each mode.

► *Refer to the Transport Assessment (EC.PA.13).*



#### A neighbourhood with the essentials on your doorstep

- One of the biggest appeals of central city living is connectivity and access to the world-class workplaces and destinations that London has to offer.



#### Prioritising sustainable travel

- The Site is hyper-connected by existing public transport linking residents to the city. The Strategic Framework has been organised to make the most of its connections to the public transport network.
- The Strategic Framework integrates and prioritises cycling and walking, promoting active travel as the most attractive options.
- Zero emission vehicles are the default where travel by private vehicle is essential.
- Access for all is prioritised to ensure that people of all abilities can move around the Site equitably and safely.



#### Enabling smart travel choices

- The Strategic Framework is anticipating potential future technologies that may change servicing arrangements and personal transportation.
- The Strategic Framework seeks flexibility in these areas, allowing for future change through a 'monitor and manage' approach in the Transport Assessment.
- The infrastructure provided will be able to adapt and respond to smart technologies and systems as they emerge.

# 7.4 Access and Movement

## Exceptional public transport connections

The Site benefits from excellent public transport connectivity with three London Underground stations and many existing bus stops on its doorstep.

Most people living and working in the development will use public transport. The pedestrian-first public realm connects to the stations and improves access for residents beyond the Site.

Targeted improvements to the stations will be agreed with TfL to ensure the existing infrastructure can accommodate future demands. Step-free access will be considered where it is not currently provided.

Assessments of bus stop infrastructure and service enhancements form part of the Transport Assessment. The bus layover at Lillie Road will be reconfigured to improve operational movements, and provide staff facilities.

▶ Refer to the Transport Assessment (EC.PA.13).

- London Underground District line
- London Underground Piccadilly line
- London Overground
- Bus route
- Bus stop



Public transport network

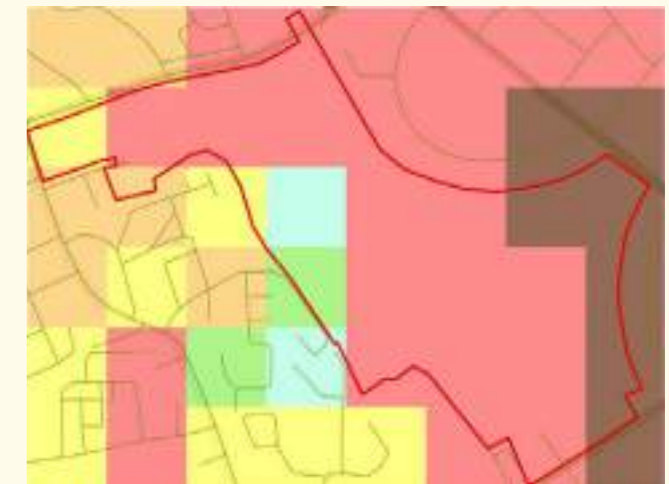

Before development connections

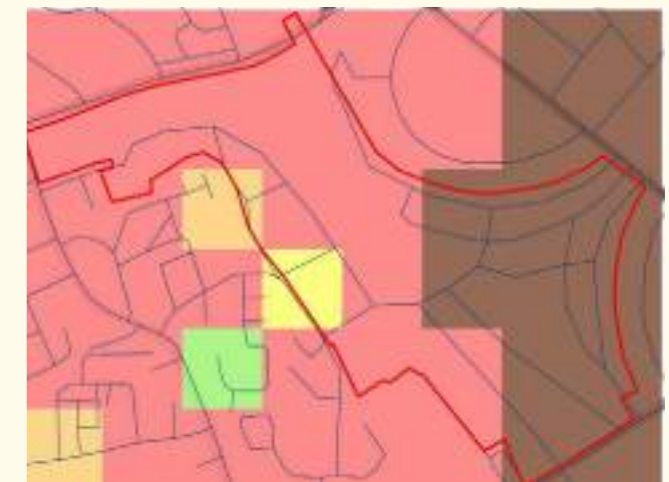

After development connections

PTAL is a measure which rates locations by distance from frequent public transport services. By adding the development connections, there is a marked improvement to Earls Court and the neighbouring Estates, before any infrastructure improvements or increased service frequency.

- |   |   |   |
|---|---|---|
| <span style="background-color: #f0f0f0; border: 1px solid #ccc; padding: 2px;"> </span> 0 (Worst) | <span style="background-color: #add8e6; border: 1px solid #ccc; padding: 2px;"> </span> 2 | <span style="background-color: #d2b48c; border: 1px solid #ccc; padding: 2px;"> </span> 5         |
| <span style="background-color: #483d8b; border: 1px solid #ccc; padding: 2px;"> </span> 1a        | <span style="background-color: #32cd32; border: 1px solid #ccc; padding: 2px;"> </span> 3 | <span style="background-color: #c0392b; border: 1px solid #ccc; padding: 2px;"> </span> 6a        |
| <span style="background-color: #add8e6; border: 1px solid #ccc; padding: 2px;"> </span> 1b        | <span style="background-color: #ffff00; border: 1px solid #ccc; padding: 2px;"> </span> 4 | <span style="background-color: #8b4513; border: 1px solid #ccc; padding: 2px;"> </span> 6b (Best) |
| <span style="color: red;">—</span> Site boundary  |   |   |



# 7.4 Access and Movement

## A walkable neighbourhood





Earls Court Development will offer a pedestrian first public realm that prioritises people and connects the Site back into the local street network.

A significant portion of the public realm is vehicle-free, with only emergency and out of hours servicing vehicles permitted access. This helps to create a safe environment and contributes to the sense of place and vibrancy of the public realm at the centre of the Site.

Some routes permit vehicular movement to ensure access to buildings. Generous, comfortable and safe space for pedestrian movement is provided on all of these routes.

The resulting pedestrian network connects with key routes around the Site to enable permeability in the wider local area.

▶ Refer to the Earls Court Design Code / Sitewide / Landscape (EC.PA.C).

-  Vehicle-free public realm (excludes emergency services access and controlled out of hours servicing)
-  Routes with pedestrian access
- Outside site boundary
-  Primary pedestrian routes
-  Pedestrian route subject to Third party agreement
-  Other pedestrian routes



Pedestrian network



Vehicle-free public realm



Routes with pedestrian access





# 7.4 Access and Movement

## An accessible public realm

Gentle slopes, ramps, steps and public lifts negotiate the transition between east and west and over the Table, from the high point of the Table Park, where the railway is crossed, to existing levels at the edges making the Site accessible for all.

The landscape turns the Site's existing levels and constraints into a topographic experience contributing to the sense of discovery and diversity of the public realm. Accessible routes are integrated into the landscape as part of the inclusive approach and vision for the Site.

Accessible routes are provided across the Illustrative Masterplan and most routes negotiate levels through gentle slopes. Where level changes require it, ramps, stairs and lifts provide a comfortable transition between those levels. Where possible, lifts are integrated into buildings for passive surveillance and management. As set out in the Control Documents, the entirety of the Site must comply with regulations that address accessible design.

▶ Refer to the Earls Court Design Code / Sitewide / Landscape (EC.PA.C).

- Level public realm
- Sloped public realm (max. 1:21 gradient)
- Ramped public realm (max. 1:15 gradient)
- Stepped connection
- Indicative lift position



Public realm gradients plan



Integrated public lifts



Ramps and gentle slopes providing step free access





# 7.4 Access and Movement

## Accessible parking and taxi drop-off

In line with the London Plan, the Illustrative Masterplan is car-lite and prioritises sustainable travel. Most residents and workers will not need to own or use a private vehicle when accessing the Site.

A policy compliant provision of accessible parking is incorporated for all land uses. Residential accessible spaces are mostly provided on Plot (spaces equivalent to 3% of unit numbers) and for other uses accessible spaces are distributed within the public realm. All parking spaces will have EV charging capability.

A zero-emissions car club is proposed to give residents access to a shared pool of private vehicles. Car club spaces are distributed across the public realm and within on-plot parking allocations.

Taxi set down areas are positioned at the edges of the Site in uncontrolled access areas, encouraging journeys to be completed by foot. Taxis are allowed through access control points to ensure anyone can be dropped off within 50m of all buildings if required.

- Taxi access
- Taxi access beyond access control point
- Taxi access within undercroft beyond access control point
- Taxi pick up / drop-off bay
- Taxi pick up / drop-off bay off-site



Taxi access and drop-off



## 7.4 Access and Movement

### Deliveries and servicing

The servicing strategy for the Illustrative Masterplan aims to be flexible to adapt to future demand whilst minimising the volume of servicing trips to and from the Site.

The aim is to minimise the impact of the Proposed Development on the existing local road network and contribute towards improved air quality in the local area. This is achieved by encouraging and facilitating the consolidation of goods at all stages of each deliveries journey to Site.

Essential servicing will be undertaken by zero emission vehicles where possible.

▶ Refer to the Framework Delivery and Servicing Plan (EC.PA.14).

- Route used by all vehicles
- Routes used by all vehicles beyond access control point
- Routes used by all vehicles beyond access control point within undercroft
- Vehicle access for out of hours servicing

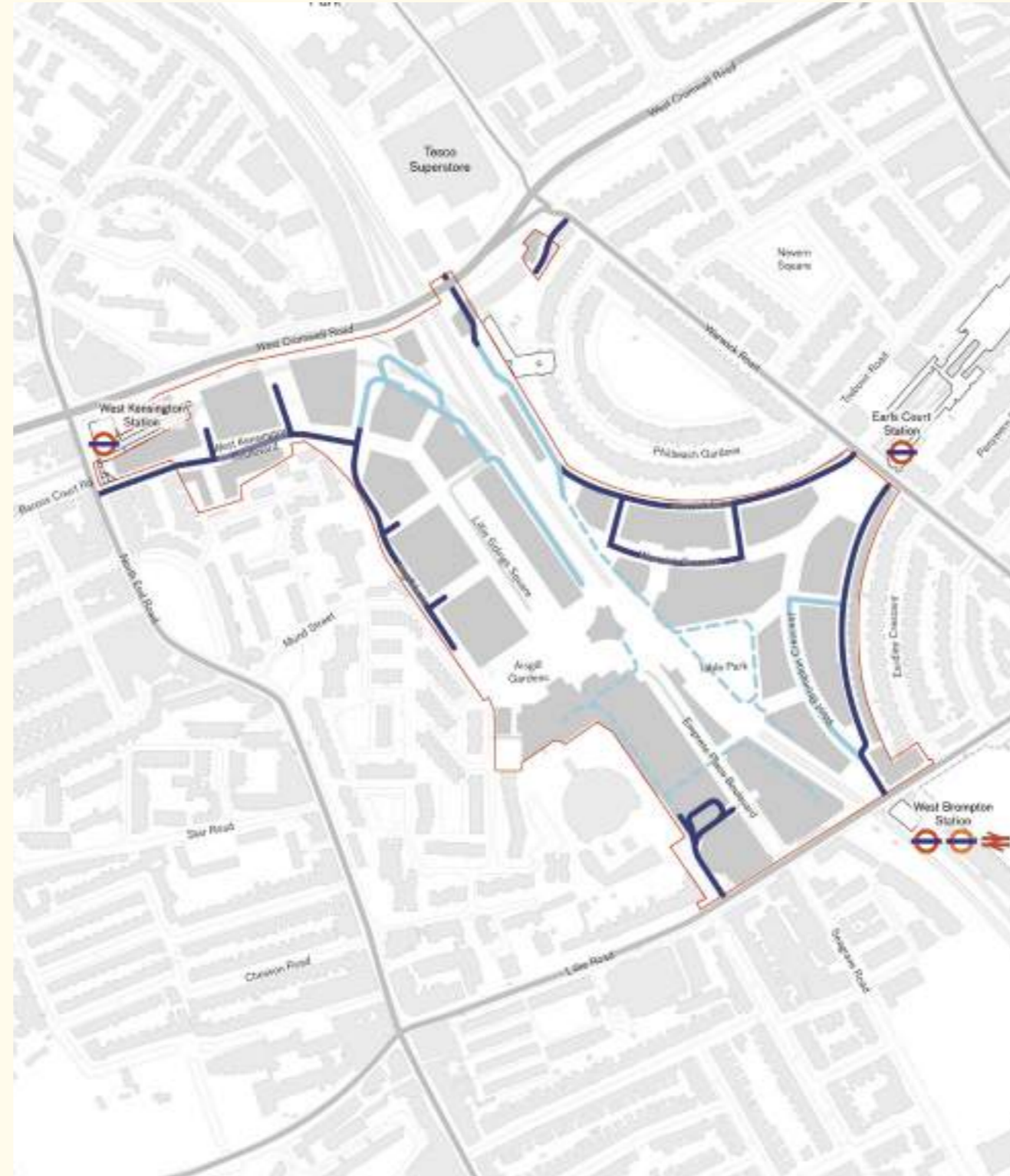

Deliveries and servicing



Entrance to service road below the Table Park to serve adjacent buildings



## 7.4 Access and Movement

### Opportunity below the Table Park

Plot EC-07 sits below the Table Park, providing circa 4,000sqm (GEA) of subterranean space for which a range of non-residential, flexible use classes (including B8 storage and distribution) are sought.

One potential development scenario, set out by the Illustrative Masterplan, is a last mile logistics facility, taking a rare opportunity to deliver a purpose built logistics space in Central London that would have the potential to reduce vehicular movements within the wider neighbourhood.

There is ever-growing demand for efficient and sustainable last mile fulfilment solutions and the need is particularly acute in this part of London. The provision of such a facility in this location is supported by the London Plan (including Policy E4), the Mayor's Transport Strategy, TfL's Cargo Bike Action Plan and the Local Plan Site Allocation, which requires delivery of non-residential floorspace at the Site to help create a sustainable and balanced community.

Key drivers for exploring the inclusion of a last mile logistics hub at Earls Court Development are:

- Replacing vehicle trips on the local highway network with sustainable delivery modes.
- Improving air quality on-site and within the local area.
- Reduced CO<sub>2</sub> emissions on-site and within the local area.

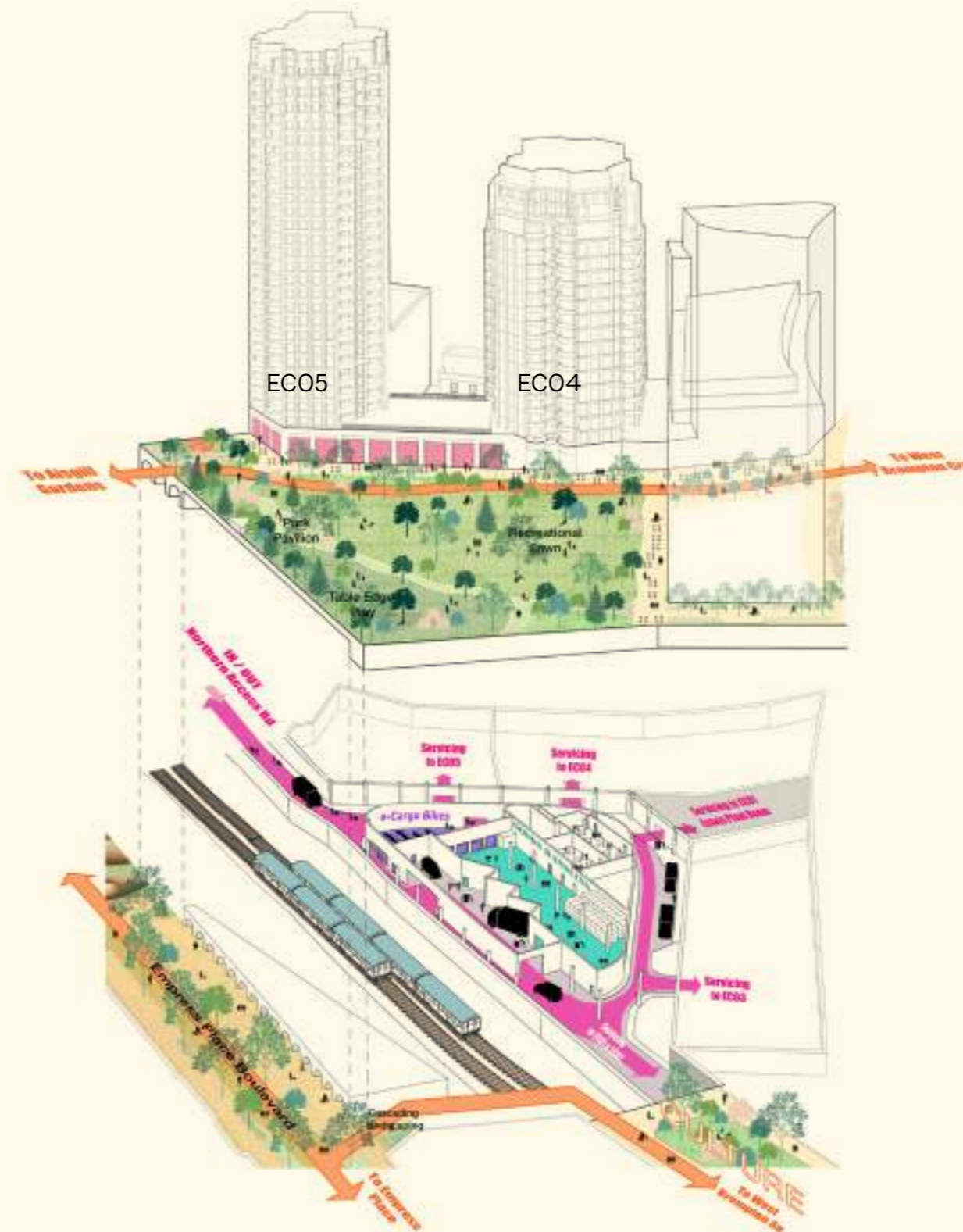
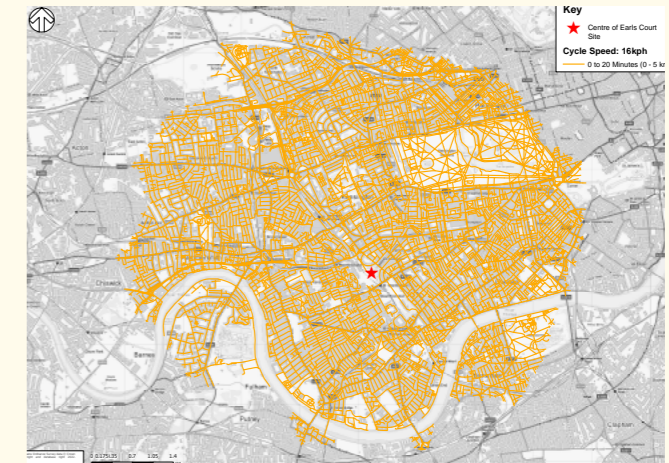

Illustration of potential last mile urban logistics under the Table Park



Delivering up to 5km from the Earls Court Site



It is envisaged that e-cargo bikes would be used to make deliveries from the facility



## 7.5 Inclusive Design

### Introduction

The Earls Court Development aims to deliver the highest standards of equitable, accessible and inclusive design. A focus on inclusion will make the new neighbourhood a place for everyone.

Working with the Public Realm Inclusivity Panel alongside experts and other stakeholders, the proposals have embraced inclusivity as a key element of the design proposals. This means placing people at the heart of the design process, acknowledging diversity and difference, considering the needs of all groups, including older people, children, and people with physical and sensory disabilities, neurodivergent individuals, and the general wellbeing and safety of all users. Creating a place where everyone feels welcome is part of the vision for the Site and aligns with TfL's Healthy Streets approach.

This section includes detail on policies and best practice that have shaped the Strategic Framework and Control Documents to create a place that fosters social inclusion. This includes:

- Vehicular movement
- Pedestrian movement
- Cycling
- Play, lighting, public facilities and wayfinding
- Entrances and circulation

► *Refer to Design and Access Statement Volume 1: Outline Component / Design Evolution & Engagement (EC.PA.08).*



# 7.5 Inclusive Design

## Inclusive design priorities

Inclusive design priorities have shaped physical and qualitative aspects of the Strategic Framework and the Control Documents.

During the design and consultation process, particularly through engagement with the Public Realm Inclusivity Panel (PRIP), six priorities were identified that influenced the overall sitewide principles of inclusive design. They consider the various aspects of social and physical challenges which need to be overcome by smart, inclusive design and were influenced by planning policy and regulations. These were:

- Legibility and wayfinding - navigation through the Site should be intuitive.
- Diversity of spaces - there should be a variety of public space to reflect the different ways people use, navigate and enjoy the public realm.
- Movement methods - footpaths and cycleways should be clearly delineated and usable for people with physical impairments.
- Areas to rest - a variety of seating types should be provided for people who have trouble walking long distances, those with neurological difficulties or people who simply need a break.

- Sensory experience - in line with the focus on nature, features that may overwhelm people with neurological processing or mental health challenges are to be avoided.
- Safe environment - pathways and entrances should be appropriately lit and designed to foster natural surveillance. Design must address how vulnerable areas, such as at external lifts or less crowded routes, can be made safe.

These priorities are woven into the principles of the Strategic Framework and the Control Documents and are described in further technical detail on the following pages.

Work will continue with the PRIP to interrogate, critique and refine design principles to ensure an inclusive and accessible approach to landscape and buildings.



Legibility and wayfinding



Areas to rest



Variety of space uses



Sensory experiences



Clarity on different modes of transport



Safe environment



## 7.5 Inclusive Design

### Vehicular movement and drop-off opportunities

The Illustrative Masterplan creates a vehicle-free public realm at the centre of the development. The walkable neighbourhood approach is justified by the exceptional access to public transport.

It is acknowledged that public transport may not be accessible for all, and the proposals have considered the needs of people who rely on community transport, taxis or minicabs as a means of transport:

- Drop-off opportunities are provided within 50m from the entrances to all buildings/uses, as recommended by the Inclusive Mobility Guidance.
- Taxi set down will be in uncontrolled access areas at the edges of the Site to encouraging walking.
- Kerb heights will be coordinated at detailed stage to ensure that ramps can deploy appropriately and provide a safe exit/entry
- Step-free routes with suitable access provisions are proposed from drop-off points to entrances of the buildings. Drop-kerbs and pedestrian crossings will be provided where appropriate.
- Drop-off points will meet dimensional and other specifications as set out in BS8300-1.



► For detailed diagram, refer to *Design and Access Statement Volume 1: Outline Component / Spatial Strategies / Access and Movement (EC.PA.08)*.

### Car parking provision

The Site will not have general parking but will provide appropriate provision of disabled parking in line with the London Plan Policies T6. 1 Residential parking and T6. 5 Non-residential disabled persons parking.

- Car parking provision for disabled people has been incorporated in line with the London Plan policies, with residential buildings providing bays equivalent to 3% of the total dwellings, and for other uses accessible spaces are distributed within the public realm.
- Car parking is proposed both on-plot and within the public realm, located in each instance close to the entrances of the buildings it serves. Travel distances will be max. 50m as recommended by the Inclusive Mobility Guidance.
- Routes from the disabled parking bays to the buildings will be level or gently sloping, with a suitable firm ground surface.
- Accessible car parking will meet dimensional and other specifications set out in Approved Document M and BS8300-1.
- Provision of accessible EV charging points will follow guidance from the 'PAS 1899: Electric vehicles – Accessible charging – Specification' and will be included at all locations for EV charging.



Electric vehicle charging point



# 7.5 Inclusive Design

## Pedestrian routes

The Illustrative Masterplan prioritises people and provides accessible and inclusive pedestrian routes throughout the Site.



- Footpaths will be wide enough to accommodate a wide range of users and to allow two wheelchair users to pass each other at any point.
- Footpaths will have suitable walking surfaces that are firm and smooth. Tactile paving will be included where appropriate to provide warning, guidance or information to people who are blind or partially sighted. The provision of tactile paving will follow the 'Guidance on the Use of Tactile Paving Surfaces' by the Department for Transport.
- Pedestrian crossings will be provided at reasonable intervals and be designed so that priority is given to the safety and comfort of pedestrians.
- Where possible, multiple routes will be integrated to provide both direct, straight lines as well as flowing, curving lines that feel more natural.
- Plentiful resting points, including a variety of seating options, will be provided where appropriate and at a maximum of 50m intervals.

- Street furniture will be located in a consistent way across the Site and placed so as not to obstruct access routes.
  - Pedestrian routes will be accompanied by plenty of greenery to benefit mental wellbeing. Trees and planting will be used to separate pedestrians from other users and reduce sensory overload.
  - Well lit pedestrian routes and provision of good sightlines will provide a perceived safety environment.
- *For detailed diagram, refer to Design and Access Statement Volume 1: Outline Component / Spatial Strategies / Access and Movement (EC.PA.08).*

## Change in level

The Site's natural level changes are integrated into the design with gently sloping public realm across the majority of the Site.



- Level changes along pedestrian routes will be addressed through gentle slopes where practicable. Where level changes are significant, external ramps, stairs and public lifts are proposed.
- Where external lifts are proposed, they have been located to be readily identifiable and linked to the stepped route. The aim is to provide the same high-quality experience to everyone regardless of the route chosen.
- The step-free route network will be resilient with alternative routes in case of lift breakdown.
- Slopes and ramps will meet the relationship between gradient, rise and length set out in BS8300-1. Level landings will be provided where appropriate with dimensions that exceed the minimum defined by the standards.
- Steps and stairs will meet dimensional and other specifications set out in BS8300-1, including but not limited to, provision of handrails and visual contrasting surfaces.

- External lifts will be wide enough to accommodate a wheelchair user with several other passengers, and to accommodate larger wheelchairs and mobility scooters. External lifts will be through-lifts and will provide weather protection over landings, controls and waiting area.
- *For detailed diagram, refer to Design and Access Statement Volume 1: Outline Component / Spatial Strategies / Access and Movement (EC.PA.08).*



## 7.5 Inclusive Design

### Cycle routes

The proposals have extended and connected to existing cycle routes, encouraging active travel for residents, visitors and workforce. The cycle network will consider the needs of disabled cyclists and will be step-free, barrier-free and spacious.

- Cycle routes will be informed by the guidance from Cycle Infrastructure Design: Local Transport Note 1/20 (LTN 1/20). Cycle lane widths will be coordinated to ensure that they can accommodate non-standard cycles, which are typically much wider, longer and heavier than a standard two-wheeled bicycle.
- Level changes along cycle routes will be as shallow as possible, with intermediate level landings between slopes where appropriate.
- Provision of comfortable space for cyclists and pedestrians will be provided.
- The interaction between cycles and pedestrians will be carefully managed within the detailed proposals. Guidance including LTN 1/20 and input from the Public Realm Inclusivity Panel (PRIP) have encouraged clarity between modes to reduce the potential conflict between cyclists and pedestrians, in particular for people who are blind and partially sighted, deaf or have a hearing impairment, and to young children and some older people.



► For detailed diagram, refer to *Design and Access Statement Volume 1: Outline Component / Spatial Strategies / Access and Movement (EC.PA.08)*.

### Cycle parking

To encourage active travel modes, the scheme will provide cycle parking and facilities in line with London Plan policy.

- Cycle parking for the public facing Ground Floor uses is accommodated in the public realm, close to activities. Commercial and residential buildings provide internal cycle storage for their workforce and residents, including policy compliant changing facilities where required.
- Cycle parking provision will take into account all user needs and cater for different types of cycles, in line with the London Plan and the guidance in Chapter 8 of the London Cycling Design Standards, such as accommodating handcycles, tandem bikes and cargo bikes.
- Cycle parking will be located consistently across the Site to ease wayfinding, and placed so that it does not obstruct access routes. Detailed design will ensure cycle stands are accessible for both people using them and people travelling along the access routes.



Cycle lanes allow for non standard bicycle types

# 7.5 Inclusive Design

## Inclusive play

Playspaces and playful landscape will be integrated across the masterplan alongside play-focused spaces such as Aisgill Gardens. Play spaces will include accessible play provision for all ages in line with London Plan policies.

- Routes to play spaces will be accessible with smooth and firm surfaces.
- Landscape will be used to provide playful elements that are accessible at ground level.
- Provision of rich sensory play opportunities, whilst also providing for quiet areas for those who require gentle sensory experiences or need to rest.
- Accessible seating and observation points for parents and carers will be provided.

► Refer to Design and Access Statement Volume 1: Outline Component / Spatial Strategies / Landscape / Play (EC.PA.08).



Example of inclusive play in the landscape

## Lighting

The lighting strategy will consider the differences in experiencing the illuminated external environment by the public, allowing people to enjoy the outdoor spaces conveniently and safely.

- Lighting will be even, avoiding creating glare, pools of bright light or strong shadows.
- Glare from bright patches of light will be avoided as they may be confusing to some visually impaired people or people who have sensory/neurological processing difficulties.
- Uplighters located at low levels on access routes will be avoided as they can also cause glare problems for some people.

► Refer to Design and Access Statement Volume 1: Outline Component / Spatial Strategies / Landscape / Lighting (EC.PA.08).



Example of integrated and sensitive lighting

## Public facilities

The proposals include public toilets that will be suitable for all users including suitable facilities for disabled people, families with young children and people of all gender identities. Changing Places toilets will be provided within the Site in line with London Plan policies.

- A variety of sanitary facilities, including unisex wheelchair-accessible toilets, WCs for ambulant disabled people, Changing Places, and family toilets and facilities will be provided at key points across the development. In Phase 1, public sanitary facilities will be provided within Plot WBO5.
- Detailed design will ensure public sanitary facilities meet dimensional requirements and other specification set out in BS8300.



Example of public facilities

## Wayfinding

The wayfinding strategy will use spatial, physical and environmental clues to assist people when moving from one place to another with inherent legibility, supported by accessible signage and information systems.

- In line with the guidance from BS8300-1, clear information and wayfinding will be provided in different formats - visual, audible or tactile forms - according to the principle of at least two senses.
- Information and signage will be located consistently where it is clearly identifiable and visible.
- Sensory clues will be considered to assist with navigation for blind or partially sighted people and those with learning difficulties.



Example of legible wayfinding



# 7.5 Inclusive Design

## Entrances and circulation will be approachable and welcoming to all

The proposal has considered specific aspects of access and movement to foster the priority of creating an inclusive community. These include:

- Residential entrances
- Residential accommodation
- Circulation
- Provision for intergenerational, multi-cultural and multi-faith communities
- Accessible and adaptable dwellings
- Wheelchair user dwelling
- Retail/commercial spaces

Whilst the Control Documents and illustrative proposals have been shaped by these aspects of access, each of these will require greater resolution through the Application(s) for Reserved Matters Approval process.



Legible entrances



Welcoming lobbies with toilet facilities



Shared resident lounges

### Residential entrances

All entrances will have a level access approach and threshold. Routes and entrances will be legible and welcoming. Surface enhancements such as changes to tactility and tone with careful positioning of planting and street furniture will highlight main residential entrances.

### Residential accommodation

The Proposed Development would deliver a range of housing tenures to meet strategic and local need, including rented and intermediate affordable homes. Provision for Later Living accommodation is factored into the Development Specification and forms a part of the Illustrative Masterplan. The design of this type of accommodation will include resident lounges, oversized corridor areas and accessible communal terraces that encourage socialising and prevent loneliness and isolation.

Provision for extended family visits will be a consideration in the layout of open plan kitchen and dining areas for all tenures.

### Circulation

Access to all levels of buildings, including roof terraces, will be accessible to all. Wheelchair access will be provided with accessible lifts and stairs for ambulant disabled people.

### Accessible and adaptable dwellings

Aligned with London Plan policy D7, as a minimum, provision across all dwellings will meet Part M4 (2) standards.

### Wheelchair user dwellings

10% of dwellings will be designed with space allowance to meet Part M4 (3) should the purchaser wish to fit them out as wheelchair accessible units.

### Retail / commercial spaces

Level approaches and thresholds will be provided. The architecture and landscaping treatment will emphasise the location of entrances, making them visible and welcoming.



# 7.5 Inclusive Design

## Standards and regulations

This page summarises the principal standards which define the regulatory context and is organised as follows:

- 1. National Standards
- 2. Planning policy
- 3. Good practice

### 1. National Standards

The access provisions have been designed in accordance to the access regulations and standards that apply, which are identified below:

- The Building Regulations 2010, Approved Document M (Access to and use of buildings) Volume 2: Building other than dwellings, HM Government, 2015 edition. Note: Amendments to AD M Volume 2 published in July 2020 take effect on 1 January, 2021 (Hereafter referred to as AD M Vol.2).
- The Building Regulations 2010, Approved Document K (Protection from falling, collision and impact), HM Government, 2013 edition. (Hereafter referred to as AD K).
- The Building Regulations 2010, Approved Document B (Fire safety) Volume 2: Buildings other than dwellings, HM Government, 2019 edition incorporating 2020 amendments. (Hereafter referred to as AD B Vol.2).

### 2. Planning policy framework

The adopted Development Plan for the Site is comprised of;

- The London Plan: Spatial Development Strategy for Greater London, Mayor of London, March 2021.
- Hammersmith & Fulham Local Plan, London Borough of Hammersmith & Fulham, February 2018.
- Local Plan, The Royal Borough of Kensington and Chelsea, September 2019.

Other documents that are material considerations include;

- National Planning Policy Framework (NPPF), Department for Levelling Up, Housing and Communities, September 2023.
- National Model Design Guide, Ministry of Housing, Communities and Local Government, 2021.
- National Design Guide, Ministry of Housing, Communities and Local Government, 2021.
- Supplementary Planning Documents and Guidance by the Greater London Authority.

Key relevant documents are:

- Accessible London SPG, GLA, October 2014;
- The Planning for Equality and Diversity in London SPG, GLA, October 2007;
- Public London Charter LPG, GLA, October 2021;

- Housing Design Standards LPG, GLA, June 2023.

- Planning Guidance, Supplementary Planning Document, London Borough of Hammersmith & Fulham, February 2018
- Access Design Guide, Supplementary Planning Document, The Royal Borough of Kensington and Chelsea, December 2010.
- Transport and Street, Supplementary Planning Document, The Royal Borough of Kensington and Chelsea, April 2016.
- Earl's Court Opportunity Area - Placemaking Framework, Supplementary Planning Document, The Royal Borough of Kensington and Chelsea, April 2023.

### 3. Good practice: inclusive design relevant guidance

The Design Team has also considered other good practice publications in relation to inclusive design. Key documents include;

- British Standard 8300:2018 Design of an Accessible and Inclusive Built Environment, Part 1: External Environment - Code of Practice, Part 2: Buildings - Code of Practice, British Standards Institution, 2018. (Hereafter referred to as BS8300-1:2018 or BS8300-2:2018)
- Inclusive Mobility. A Guide to Best Practice on Access to Pedestrian and Transport Infrastructure. Department for Transport, December 2021.

- Inclusive Urban Design: A guide to creating accessible public spaces, David Bonnett Associates, BSI, 2013.
- Improving Walkability: Good Practice Guidance on Improving Pedestrian Conditions as Part of Development Opportunities, Transport for London, 2005.
- Guidance on the Use of Tactile Paving Surfaces, Department for Transport 2021.
- London Cycling Design Standards, TfL, 2016.
- A Guide to Inclusive Cycling (fourth edition), Wheels for Wellbeing, 2020.
- Cycle Infrastructure Design: Local Transport Note 1/20, Department for Transport, 2020.
- Healthy Streets for London, Prioritising walking, cycling and public transport to create a healthy city, Mayor of London & Transport for London.
- Child-Friendly Places, Supplementary Planning Document, London Borough of Hackney, July 2021.
- Designing for Accessibility, CAE/RIBA Publishing, 2012.
- PAS 6364 Design for the mind - Neurodiversity and the built environment - Guide. British Standards Institution, 2022.

Access standards are in a continuing state of development because of changing expectations and legislation. Therefore it is important that access and inclusivity are considered and refined throughout the design process. The design of the scheme has sought to interpret these standards to provide the best possible level of inclusive design.



## 7.6 Circular Economy

### Introduction

The development has sought to adopt the key principles of durability, disassembly, reuse and adaptability to enable the efficient use of natural resources.

This section elaborates on the circular economy approach that has informed the Strategic Framework, and will continue through the detailed design of the Plots and public realm.

► *Refer to Whole Life Carbon and Circular Economy Assessment (EC.PA.24).*

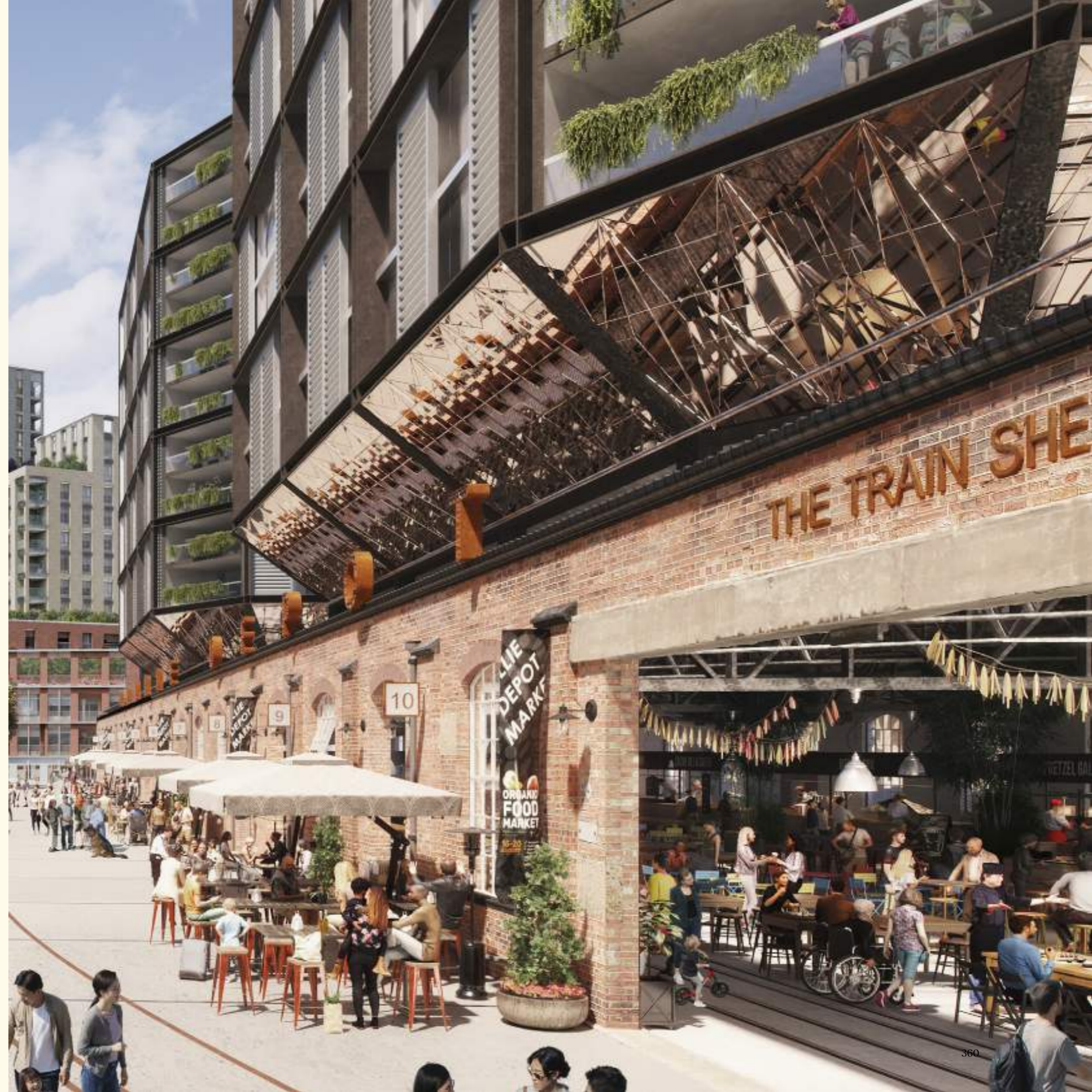



## 7.6 Circular Economy

### Working with the Site

Durability, disassembly, reuse and adaptability are embedded through the retention of existing structures and reuse of materials in line with London Plan SI7.

An initial sitewide assessment has been made of existing buildings, structures and surfaces with the ambition to;

- Maximise reuse of material from essential demolition.
- Reclaim materials for use in the public realm and buildings.
- Retain buildings and structures which are suited for the requirements of the Site.

This will inform decisions on embodied carbon, contributing to the commitment to reduce the up-front embodied carbon of buildings, targeting  $<500\text{kgCO}_2/\text{m}^2$  for domestic and  $<650\text{kgCO}_2/\text{m}^2$  for non-domestic uses, and supporting the aspiration to go beyond.



Concourse structures and foundation have been assessed.



All existing buildings have been assessed against the requirements for the Site, alongside an initial qualitative and quantitative assessment of their materials.

### Materials and Waste

The construction and operation of the development will seek to minimise the carbon impact of its material usage and operational waste.

The development will target using 20% of materials that are reused and/or contain recycled content, and will explore the use of regenerative materials and technologies to enable the circular economy.

During construction, the aim is to minimise construction waste by diverting more than 95% from landfill for reuse, recycling or recovery.

Once the development opens, the aspiration is to enable more than 65% of operational waste from all users to be diverted from landfill.



Structures not suitable for reuse will be assessed for recycling on site, to reduce construction waste to landfill



## 7.7 Microclimate

### Introduction

The development seeks to provide comfortable living environments internally and externally by positively improving the microclimate. The evolution of the Spatial Framework has been informed by evaluation of the microclimate; guiding the optimisation of the Site for good quality homes, workplaces and public spaces in this important Opportunity Area.

This section provides more detail on the environmental analysis of the Illustrative Masterplan with respect to:

- Daylight, sunlight and overshadowing
- Wind
- Air quality

In accordance with the EIA Regulations, the ES reports on the likely environmental effects of the Proposed Development and any required mitigation, including in respect of microclimate, ensuring that the masterplan strategies are robust and underpinned by evidence.

► *Refer to the Environmental Statement / Chapters 10, 15 and 16 (EC.PA.12)*





## 7.7 Microclimate

### Daylight, sunlight and overshadowing

Daylight, sunlight and overshadowing analysis has been conducted throughout the development of the Illustrative Masterplan and has informed the Strategic Framework. The masterplan architect team worked closely with the technical advisors to design a scheme that makes the most of available daylight and sunlight.

Public realm spaces, residential courtyards and upper level amenity space on podiums and roofs have been prioritised, alongside potential impacts of the development on neighbours.

As play space is predominantly allocated in the public realm, much of the massing iteration has focused on ensuring good levels of sunlight in the key public spaces. The diagrams show that Table Park, Aisgill Gardens, Warwick Square and West Brompton Square, and the green edge to the existing Estates receive good levels of sunlight throughout the year.

As development is permissible within any part of the Maximum Envelope, this has formed the basis for assessment within the Environmental Impact Assessment. Future applications for Reserved Matters Approval will undertake further daylight and sunlight testing to optimise the performance of buildings and spaces.



21st March (spring equinox)



21st June (summer solstice)

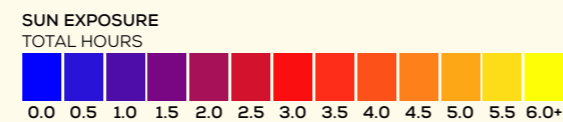

☐ Main public spaces

The above analysis has been conducted by GIA as part of the Internal Daylight, Sunlight and Overshadowing Report.

► Refer to the Environmental Statement / Chapter 15 (EC.PA.12)



## 7.7 Microclimate

### Wind

The Illustrative Masterplan has been assessed for its performance in terms of wind and microclimate by environmental engineering consultancy, RWDI, to ensure the public realm and amenity spaces are comfortable.

Throughout the design process wind and microclimate software was used to assess the emerging scheme, allowing the Design Team to iteratively and collaboratively determine optimal massing arrangements.

Wind tunnel testing has been undertaken as part of the Environmental Impact Assessment for the Hybrid Planning Applications. According to the receptors tested, the majority of areas would have wind conditions suitable for the intended uses.

In some areas, additional mitigation measures may be required to ensure optimum wind levels for the intended use. These will be subject to further iterative testing during the detailed design process to inform the applications for Reserved Matters Approval for the landscape and buildings.

► *Refer to the Environmental Statement / Chapter 16 (EC.PA.12)*



Wind tunnel testing facility - Detail Component with All Phases Outline Component and cumulative surrounding buildings (view from the west)

## 7.7 Microclimate

### Air Quality

The development aims to improve the air quality of the Site and to achieve at least 10% lower pollutant levels on-site compared to the whole borough average.

A multi-faceted approach to air quality is required, including building layout and orientation, building services, transport and landscape. In order to ascertain the success of such interventions, the air quality of the Site must be measured. This is already underway, and will continue, with data made publicly available for at least ten years post completion.

The key decision to repurpose the existing Table Structure and enclose this section of the West London Railway Line on the east and west sides will limit pollutant egress from cross-site rail traffic.

Opportunities for air flow will be created by optimising the space between buildings and combustion engines will not be utilised in the buildings or public realm other than for life safety (e.g. backup generators, which will use sustainable biofuels, until they can be replaced by electric back-up).

As another pollutant source, vehicles will be restricted to perimeters of the Proposed Development in order to maximise car free public realm. There will be with a focus on supporting electric vehicles (or equivalent) and limiting

combustion vehicles to reduce air pollution where vehicular access is provided, aligning with Healthy Streets principles.

To support this, electric charging points to all parking spaces will be provided to promote electric vehicle uptake. In addition to this, an electric car club with spaces for 25 vehicles will be provided to promote vehicle sharing for residents and the wider community.

Off-site consolidation centres will be encouraged to control numbers of vehicles needed on to Site and in surrounding roads, and to support sustainable last mile services within and beyond the boundary of the Proposed Development.

The design of the landscape can also help to clean air and screen and filter pollutants. The development aims to implement a range of continuous planting barriers, pollutant reducing materials and technologies at strategic locations, particularly at main access points and alongside the rail to trap pollutants from roads and rail.

► *Refer to the Environmental Statement / Chapter 10 (EC.PA.12)*



Air monitor on Site to the south of the existing Table Structure



## 7.8 Utilities

### Introduction

The Site will integrate highly sustainable strategies to allow for long-term efficiency.

This section sets out how the water, energy, digital and other utility strategies have been coordinated with the Strategic Framework. Each strategy describes its contribution to ensuring a long-term, phasable solution. The holistic approach to utilities plays a critical role in achieving the project's sustainability ambitions, as the development seeks to co-locate energy network plant and equipment; minimising embodied carbon, maximising operational efficiency and creating more opportunities for amenity use.



# 7.8 Utilities

## Water strategy

The Earls Court Development water strategy aims to minimise the consumption of potable water on the Site by harvesting rainwater and exploring re-circulation within buildings and landscape. It will significantly reduce the rainwater runoff from the Site compared with existing conditions and improve beyond greenfield rates of runoff.

A water neutral landscape is made possible by a commitment to capture, recycle and reuse water where possible, with 40 days of rainwater and/or greywater storage held on Site available for irrigation. Water demand is minimised by the specification of drought tolerant planting mixes and by assuming drip irrigation. These measures make it technically feasible to irrigate the public realm with only harvested rainwater after the planting has been established. Section 7.3 provides further detail on how water will be experienced within the landscape design.

In winter months, when there is surplus water and the harvesting tanks are full, surface water will be managed with a mixed strategy of ground infiltration (where site conditions allow it) and limited use of the existing drainage network.

Where public realm sits on terra firma, Sustainable Drainage Systems (SuDS) features within the landscape discharge directly to

ground. Where the public realm is raised on new structure, SuDS features are proposed within the landscape build up above the structure. This type of attenuation will reduce flow rates before the discharge reaches the drainage network or infiltration tanks to terra firma.

Minimising the pumping of waste water in both the foul and surface water networks has been a priority. Due to site levels there are two catchment areas that require a pumped solution, but all other parts of the Site can be gravity-fed to storage and infiltration tanks or the existing sewer.

Within buildings, demand will be reduced by using highly efficient fittings across all uses and tenures. The aim is to limit water usage to 80l/p/d in residential buildings, which is 24% better than Building Regulations requirements.

On top of this, greywater recycling (the treatment and reuse of waste water from showers and sinks for non-potable uses such as flushing toilets and on-plot irrigation of landscaping) will be included where appropriate.

Vacuum drainage will be explored as a potential method for reducing water consumption in office, cultural, food & beverage and retail buildings during the detailed design stages, alongside other water strategies such as blue roofs.

► Refer to *Integrated Water Management Strategy (EC.PA.41)* and *Design and Access Statement Volume 1: Outline Component / Spatial Strategies / Landscape / Water (EC.PA.08)*.

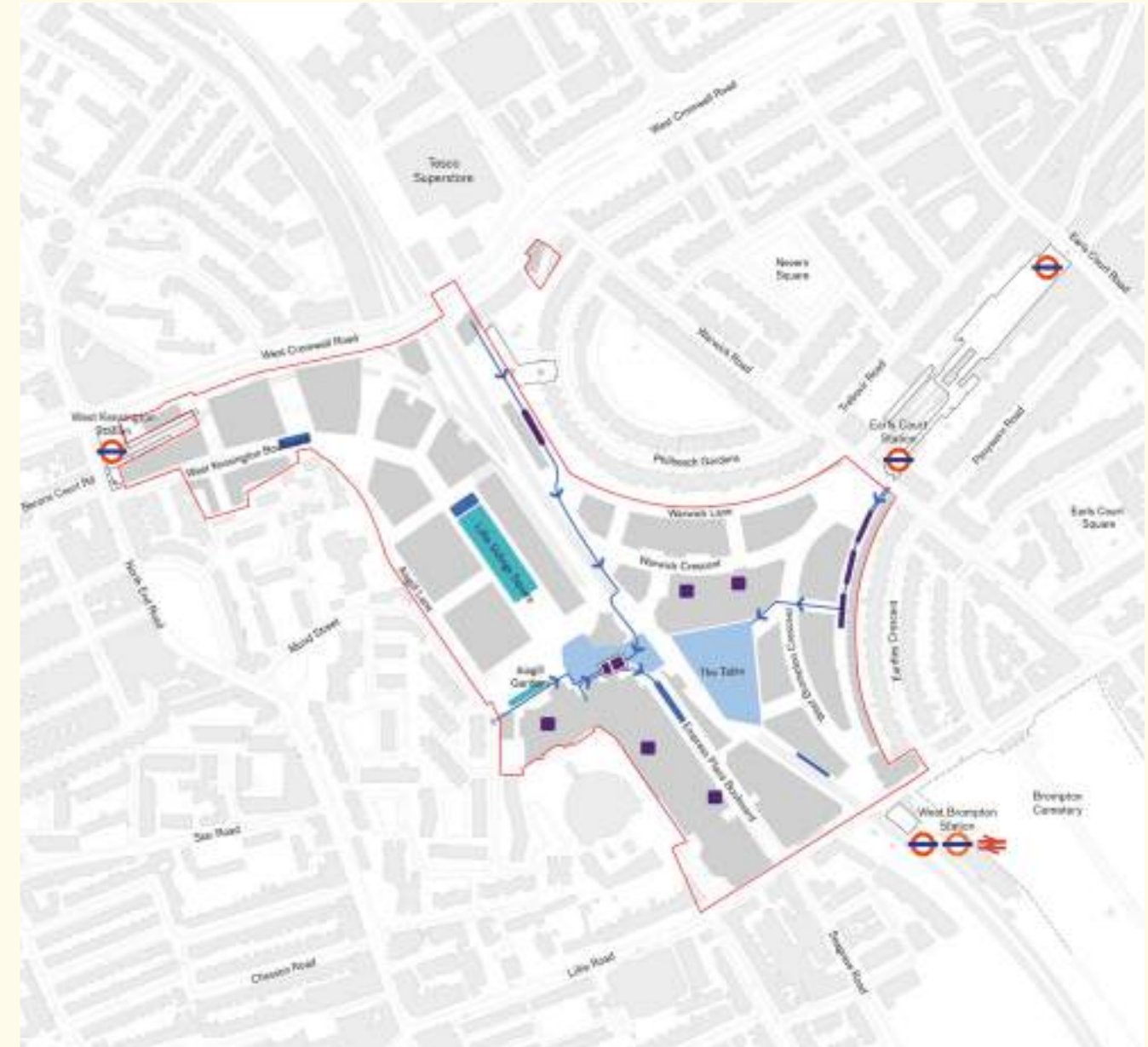

Illustrative surface water management strategy

- Infiltration tanks
- Rainwater harvesting in public realm
- Rainwater harvesting tanks on Plot
- Cascades rainwater tanks
- Centralised rainwater tank integrated with podium attenuation

# 7.8 Utilities

## Utilities strategy

A utility corridor route has been coordinated and safeguarded around the Site accommodating all services bringing electricity, water, drainage and telecommunications to all Plots.

The corridor runs below ground level finishes, or within the landscape build up above new structures.

It is not expected that utilities are to be adopted within the site boundary. An estate management company will be set up to manage, maintain and ensure long term stewardship across the Site.

The relevant utilities stakeholders have been consulted during the pre-application stage on existing utilities infrastructure, requirements for the development and servicing of the Earls Court Development, and the potential for any reinforcement measures or diversions.

### Electricity

The electricity network in the area is operated by UK Power Networks. 25MVA has been secured at the existing West Brompton substation.

Should additional electrical capacity be required, spatial provision for a new primary substation has been identified within the Earls Court Development located on West Cromwell Road to facilitate the provision of a new 132kV/11kV primary substation. The proposed infrastructure in this location would be suitable

to accommodate the additional capacity required under all peak electrical demand summaries.

At this stage the provisional location has been identified only with UKPN to undertake a space proving exercise. Should the need for additional capacity be identified, further consultation would be undertaken with the relevant stakeholders for technical and spatial considerations, including UKPN, TfL and other utility providers in the area.

### Potable Water

Potable water will be supplied to the Proposed Development by Thames Water.

### Foul and Surface Water

Thames Water have been consulted on the development's impacts on the existing sewer network. The sewers in the area are already under significant pressure and minimising discharge has been an important driver in the technical design of the masterplan.

### Telecommunications

Openreach are the primary telecoms infrastructure provider in the area. There are diverse connection points available to the Site. The design of the utility routes allow for multiple data providers.

► Refer to *Utilities and Services Infrastructure Strategy (EC.PA.38)*.



Service connection points and illustrative utility corridor route

- Utilities corridor
- HV electricity connection
- Potential additional HV electricity connection and indicative location for new substation
- Potable water connections
- Telecommunication connections
- Sewage outfalls

# 7.8 Utilities

## Energy strategy

As part of the vision to Go Beyond Net Zero, the energy strategy plays a significant role by delivering zero carbon operational energy from Day One.

The Earls Court Development will be a combustion-free scheme and will use only electricity based generation systems, eliminating emissions within the development. The aim is to be energy positive, to provide low carbon, low cost energy to the Proposed Development and its neighbours by exporting surplus energy.

The strategy proposes a 5<sup>th</sup> generation ambient loop energy network: industry-leading and one of the largest built in the UK when complete. Totally combustion free, unlike typical Combined Heat and Power (CHP) district networks, it uses low temperature water as the mode of energy transfer to deliver heating and cooling to the Proposed Development.

Three interconnected loops of water, at a temperature of between 15-25°C, enable energy exchange between buildings within the development. The energy is then used as heating – upgraded as required – or converted to cooling dependant on the Plot or building needs. Any spare energy is stored on site, as warm water or electricity.

Commercial and residential buildings have differing energy profiles and needs. Commercial buildings are likely to require cooling all year

round, whereas residential buildings will always require hot water but at different times of the day. Cooling processes reject heat to the ambient loop and heating processes can use the resulting rejected heat where possible. One of the key benefits of this system when deployed in a mixed use scheme, is that it allows more energy balancing across the network – reducing the overall energy requirements, increasing efficiency, and reducing running costs whilst allowing more energy sharing.

Connected initially to air source heat pumps, and potentially ground source heat pumps, these technologies are extremely efficient. For every unit of energy put in (usually electricity) they deliver more than two or three units in return; this is how the development will be operationally carbon neutral as a minimum.

A unique feature of the ambient loop, when compared to legacy CHP district systems, is that other sources of waste heat or energy can be added. This simple additionality also future-proofs the proposals allowing for the integration with new forms of renewable/green energy generation and capture technologies as they come on line. Furthermore, the Proposed Development has other renewable energy creation systems such as PV - sufficient to power at least 65 homes initially – around the Site.

► Refer to Energy Strategy (EC.PA.22).

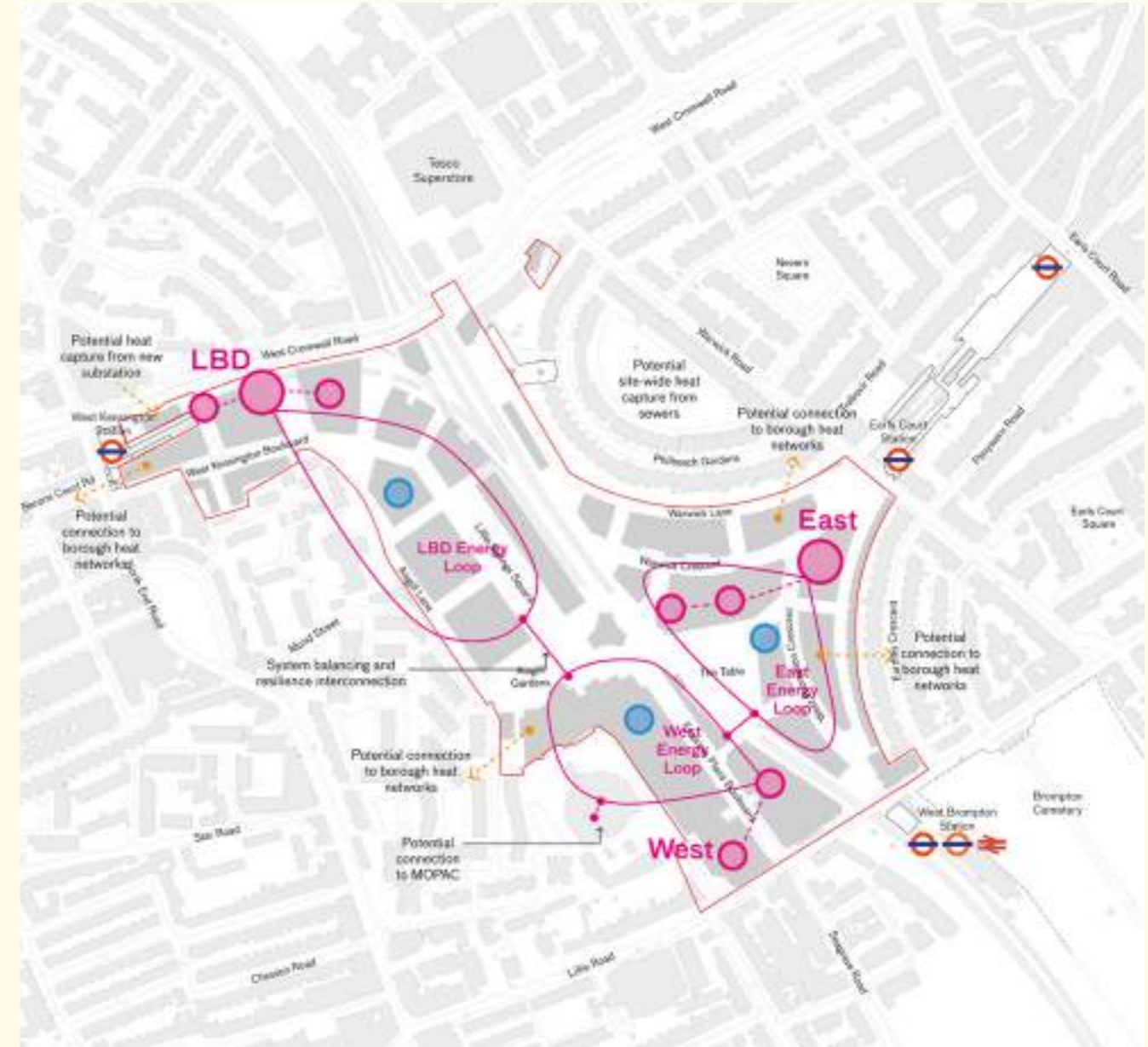

Diagram of 5<sup>th</sup> generation ambient loop energy sharing network

- 15-20°C water contained in an energy loop
- Heat pumps on roofs of buildings maintain the temperature of the loop
- Location of central thermal stores within plant space of building Plots



## 7.8 Utilities

### Towards a digital strategy

The vision and its masterplan guiding priorities, principles and place pillars, will all be supported, enacted and measured by ensuring the Earls Court Development is fully connected and future-enabled, in all senses. The digital strategy enables this connectivity, using current and emerging technologies, with the right digital infrastructure, principles and fore-planning in place.

To be a global exemplar of the future of the sustainable city, masterplans must dynamically evolve, allowing emerging technologies and seamless tools to enhance everyone's experience, underpinning the quality and uniqueness of the place. To create a better piece of city it will need to be a 'smarter' piece of city.

Key themes have been set out to create a coherent digital approach, around user experience, technologies, systems, data and processes. These are consistently applied, from 'temporary' to in use:

- Stakeholder and user experience driven
- Dynamically digital throughout
- Connectivity and collaboration
- Open and inclusive

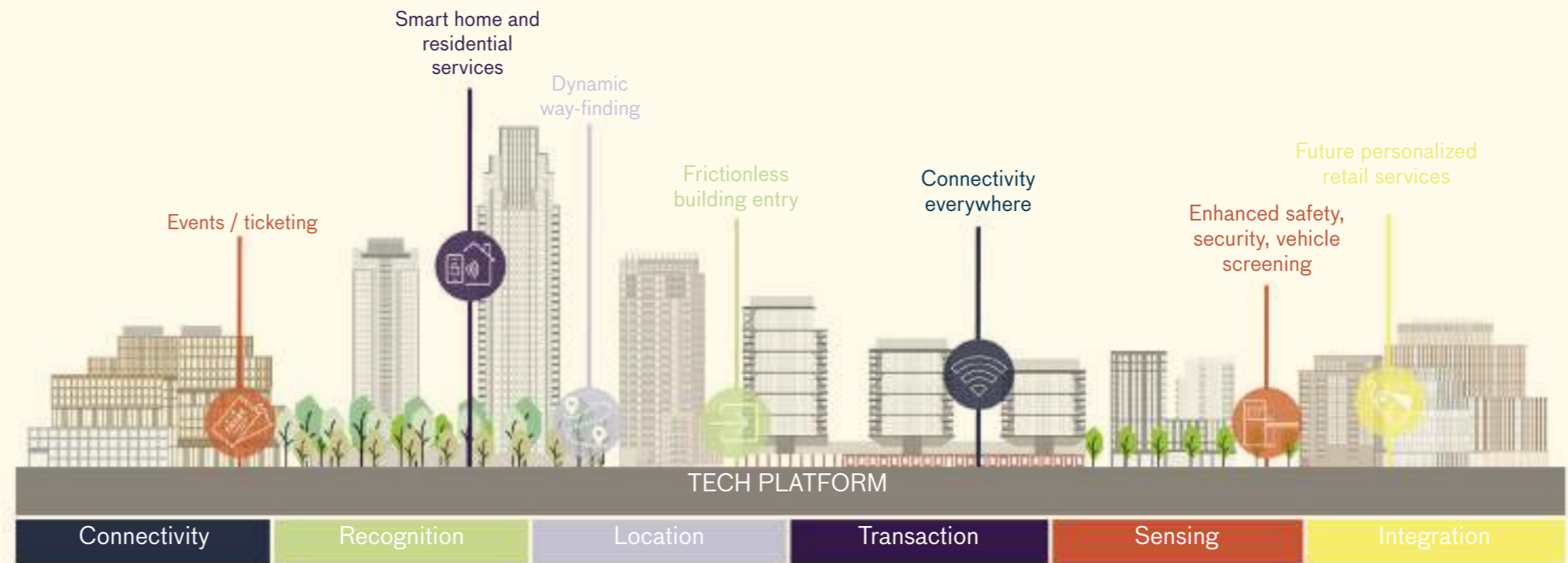

Earls Court Development digital strategy diagram



# 7.8 Utilities

## Towards a digital strategy

### Stakeholder and user experience driven

Success comes from people and how they experience the places we create – the built environment, public realm and neighbourhoods. Introducing a digital element should be about how people feel, interact and experience the place and how they access services and information in ways that enrich their lives. It should enhance how people live, work, shop, visit and play, by creating exciting and inspiring places and spaces supported by seamless, frictionless digital experiences.

### Dynamically digital throughout

The sitewide integrated approach to the digital strategy is people centric, flexible and adaptable, accommodating change over time: critical to a resilient and sustainable development.

Technology advances daily and the potential of digital networks is increasing similarly. The key to being ‘smart’ will be flexibility. The implemented infrastructure will be flexible, capable of supporting current needs but able to change to align with what the future technologies offer.

### Connectivity and collaboration

A high quality digital experience demands fast, reliable, with excellent network connectivity as a minimum standard. This means high capacity Wi-Fi and excellent cellular capacity and coverage; the public realm infrastructure is

designed to integrate this capacity now, and is future proofed from the outset. The Site must be capable of satisfying the most data intensive occupiers, businesses and home leisure experiences. Free Wi-Fi in the public realm is a must.

Connectivity also means promoting collaboration, supporting networks of communication and sharing, between businesses, within local communities, and across into the wider neighbourhoods.

### Open and inclusive

The digital strategy is set out on the principles of openness and inclusivity to enhance safety and security. A careful approach to privacy issues ensures that protocols are legally robust and ethically sound. Cyber Security is a key consideration that runs through the digital strategy.

‘Smart city’ infrastructure delivers safe channels to share information to and from users and their networks to support and enhance experiences. This approach aims to create a competitive edge for innovators and businesses, start-ups and disruptors as well as major users. Mobile apps, location-based analytics and footfall measurement systems, for example, all add value and increase efficiency and safety. The digital infrastructure will reinforce other strategies: energy consumption data will allow efficient running of the energy network, whilst data analytics will support ESG reporting.

## Key themes

### Infrastructure and systems delivered by projects

A robust digital infrastructure for technology and systems is planned within individual buildings, public realm and existing assets that accommodates change within a coherent sitewide framework.

Ubiquitous connectivity and choice i.e. broadband, mobile, Wi-Fi and ultra-fast speeds, full fibre and 5G ready, is designed in. This infrastructure is available for users of public spaces and occupiers of buildings including future proofing for wireless and Internet of Things (IoT) devices.

### Project delivery, asset management systems and processes

The tools and platforms owned and used by development teams to share project information and manage delivery will follow a set of integrated asset information protocols and strategies – from inception to operation, with the ultimate aim: a Digital Twin.

The digital strategy should enhance the places created for people: desirable, frictionless and vibrant places to live, work and visit.

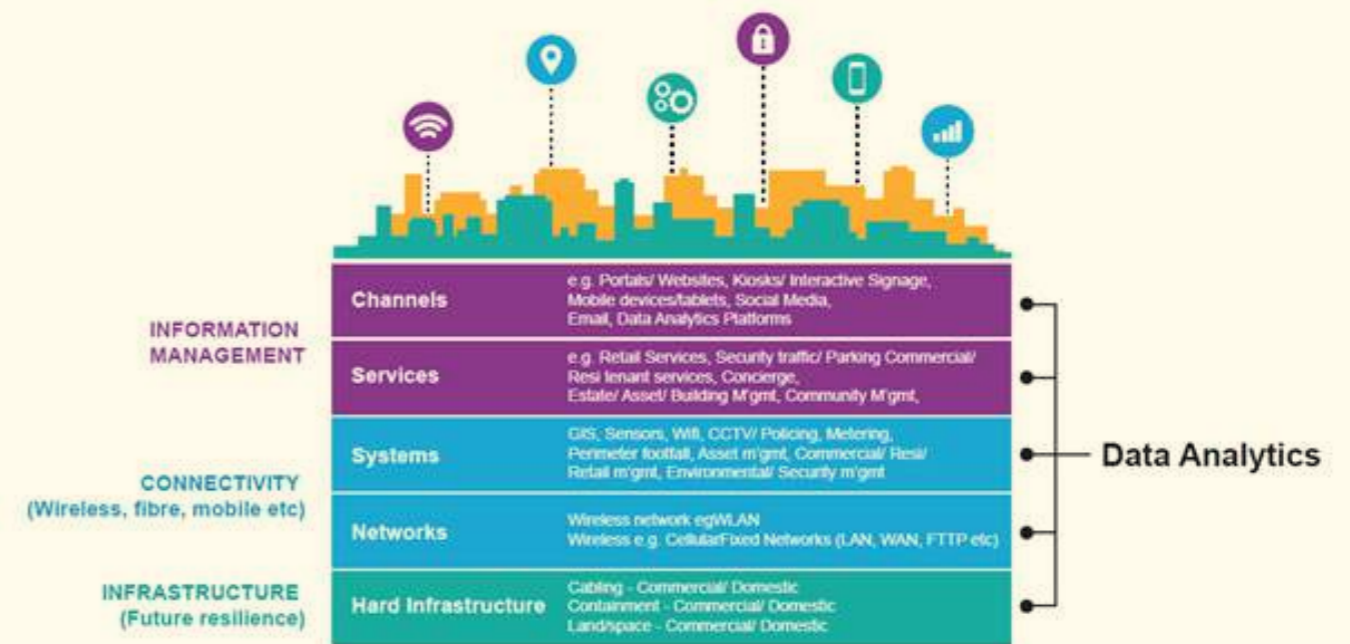

Approach to embedding the digital strategy



## 7.9 Health and Safety

### Introduction

The safety of buildings, and the safety of occupiers and users of the Proposed Development, are of paramount importance and are central to the Applicant's approach to the design, procurement, delivery, operation and maintenance of the Earls Court Site.

This section outlines the strategies that have been developed to underpin and ensure future deliverability of the masterplan.

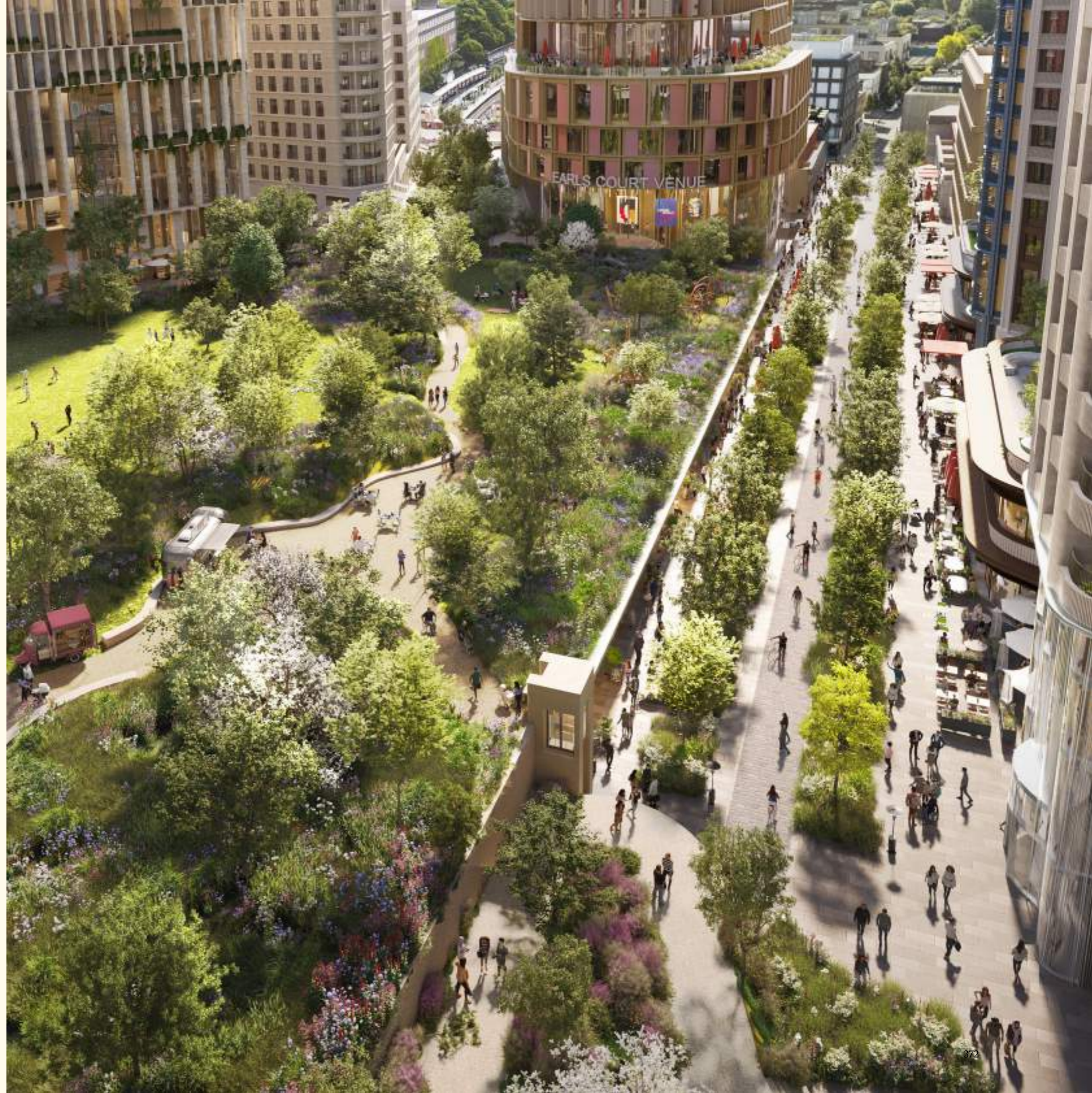

## 7.9 Health and Safety

### Design and Construction

The approach to design and construction seeks out design solutions which reduce the need for labour on-site, bringing forward infrastructure and construction solutions which allow high levels of pre-fabrication off site.

Modern Methods of Construction ('MMC') are one method by which this could be achieved. Such solutions have the added health and safety benefits of reducing vehicle movements to and from site, and minimising material waste. Additionally, the Applicant will promote the adoption of increased mechanisation and new technology in relation to on-site construction delivery as it becomes available to the industry.

Throughout the evolution of the design to date, input and feedback has been applied to the Proposed Development by safety professionals, consultants and best in class designers. The Applicant has also engaged with security advisors to inform the Proposed Development.



MMC: Prefabricated building elements can reduce time spent on-site

### Access and Maintenance

The Applicant will bring forward infrastructure, buildings and public realm designs which at their heart consider how they will be constructed and maintained, ensuring that safety and health is prioritised for the buildability and operability of the Proposed Development.

An example of this is the incorporation of building maintenance units for the purpose of cleaning and maintaining the façades of buildings in lieu of methods such as abseiling which put people at unnecessary increased risk of harm.

The design of the public realm throughout the Proposed Development has focused on the health, safety and wellbeing of occupiers and visitors to the Proposed Development. The Applicant's submission has been informed from a very early stage by local residents and end users through a forum known as the Public Realm Inclusivity Panel (PRIP). The PRIP has hugely assisted in the development of the design of the public realm, providing thoughts and feedback to ensure that the Proposed Development will be an environment which is physically safe, provides personal security and is accessible for all.

At a more formal level the emergency services have been engaged through the key stages of design to ensure that all areas of public realm can be accessed and that fire tenders can access all buildings.

### Safety and Legislation

The Proposed Development has been brought forward in a manner which prepares itself for legislative changes.

This has been considered from both a technical performance standpoint but also in consideration of the continuing adjustment, realignment and changes to Building Regulations, and the associated roles and responsibilities of the various parties who will design, procure and deliver the scheme.

Through the design process the Applicant has been mindful of the evolving policy changes and has incorporated design solutions ahead of these being enshrined in law and regulation. Such measures include but are not limited to; dual escape stairs in buildings over 20 metres in height as well as dedicated fire lifts.

# 8 Phasing and Delivery



## 8.1 Phasing and Delivery

The phasing strategy has been carefully considered to work with the Site's complex infrastructure and limited access, whilst delivering on the ambition to bring the wonder back to Earls Court from the start. The Proposed Development is currently anticipated to be delivered in eight main phases and over an estimated programme of approximately 19 years.

The eight main phases encompass the full build out of the Proposed Development. The indicative development programme is based on the assumption that planning permission is granted in Q3 2025. Elements of infrastructure works are expected to commence prior to Q3 2025.

This section provides more detail on the timescale for construction and the proposed strategies to manage the Proposed Development as it evolves over the next two decades.

- ▶ *Refer to the Indicative Phasing Strategy (EC.PA.48)*
- ▶ *Refer to the Temporary Uses Strategy (EC.PA.49)*
- ▶ *Refer to the Framework Construction Management Plan (EC.PA.15)*



# 8.1 Phasing and Delivery

## Phasing principles

The approach to phasing is underpinned by the following principles:

### Create a mixed use destination from the outset

Each phase has been considered to create a mixed use destination from the start. Phase One delivers a mixture of homes and commercial workspace, alongside the provision of retail, leisure, cafés and restaurants, culture and new public spaces.

### Early delivery of key connections and public realm

Creating a vehicle-free east-west connection linking Aisgill Gardens, The Cascades, Table Park and Warwick Square, is key to increasing connectivity through the Site.

### Build in both boroughs

The Site is located in both the London Borough of Hammersmith and Fulham (LBHF) and the Royal Borough of Kensington and Chelsea (RBKC), and the phasing strategy has been devised to deliver on their respective priorities.

## Continue to deliver temporary uses to further activate the Site during construction

The scale of the Site and associated timeline of development will present opportunities for temporary uses. These provide additional activation of the Site and have the potential to mitigate the impact of construction, for example, through addressing temporary edge conditions.

## Minimise impact of construction on neighbours and future occupants

There are limited vehicular access points for construction and the development has some complex interfaces with rail infrastructure. The phasing strategy has been devised to reduce, where possible, direct interfaces between construction activity and completed phases.

## Facilitate the relocation of Lillie Bridge Depot

Lillie Bridge Depot will not be vacated for a number of years following the successful determination of the planning application. As such, it will feature in later phases.

## Delivery of permanent public realm

Legacy public realm has been designed with future phasing in mind to maximise the amount of permanent landscape delivered in each phase.

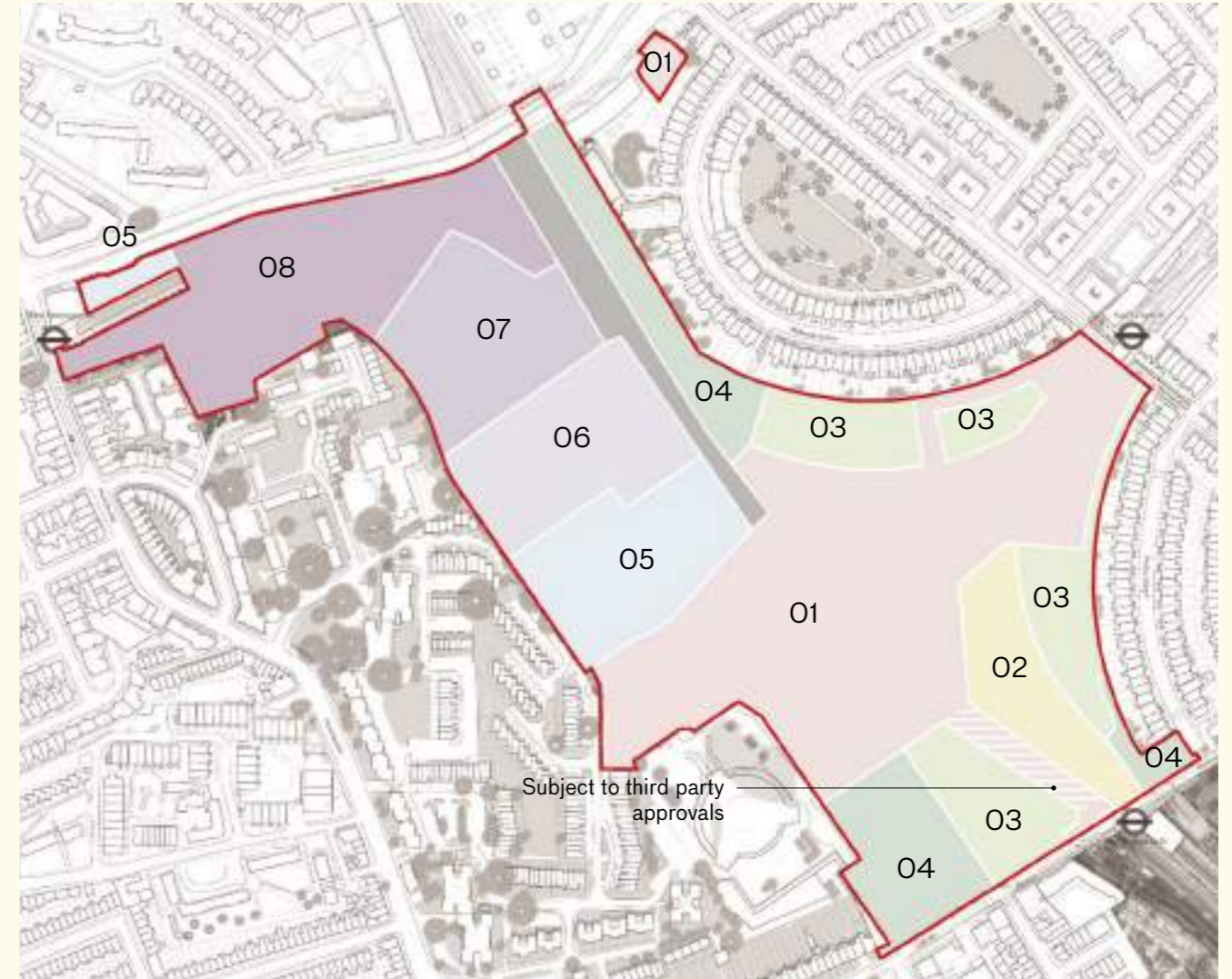

Indicative phasing plan

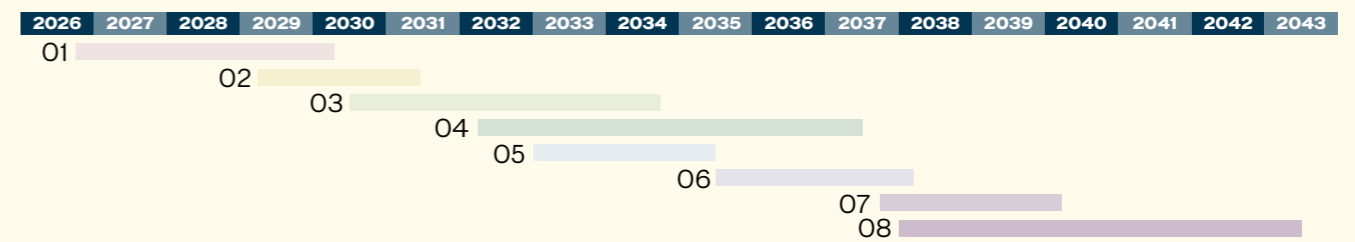

Indicative phasing timeline

# 8.1 Phasing and Delivery

## Phasing scenarios

The Hybrid Planning Applications consider and assess two scenarios; All Phases and Early Phases.

The eight main phases encompass the full build out of the Proposed Development. The indicative development programme is based on the assumption that planning permission is secured in Q3 2025. Elements of infrastructure works are expected to commence prior to Q3 2025. Where applicable, separate applications have already been submitted or may be submitted for these works, as described in chapter 5 and the Infrastructure Works section of the submitted Environmental Statement. The impacts of these works have been considered as part of the Environmental Impact Assessment (EIA) and in relevant planning application documents for completeness and robustness.

Therefore, for the purpose of the indicative development programme, the Proposed Development works are anticipated to be undertaken over 13 years for the Early Phases (completion targeted for Q2 2037) and 19 years for the All Phases (completion Q2 2043).

No significant delay is anticipated between the phases. However, realising vacant possession of the Lillie Bridge Depot is complex and whilst an indicative programme has been agreed with London Underground Limited (LUL), it is subject to ongoing review, detailed preparation and design, and additional consents. It may change and could delay vacant possession beyond the timescales currently anticipated.

Due to this, the Hybrid Planning Applications consider and assess two different scenarios. These are:

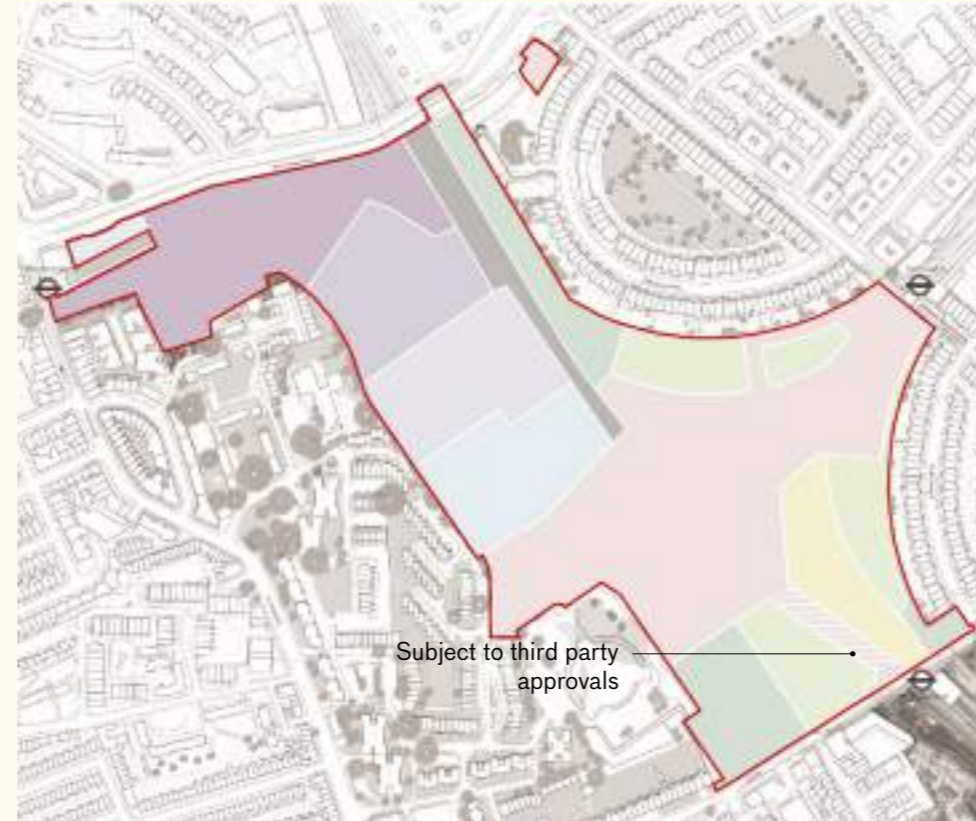

### 1. All Phases scenario

Comprising the entirety of the Proposed Development. This is currently anticipated for completion by 2043.

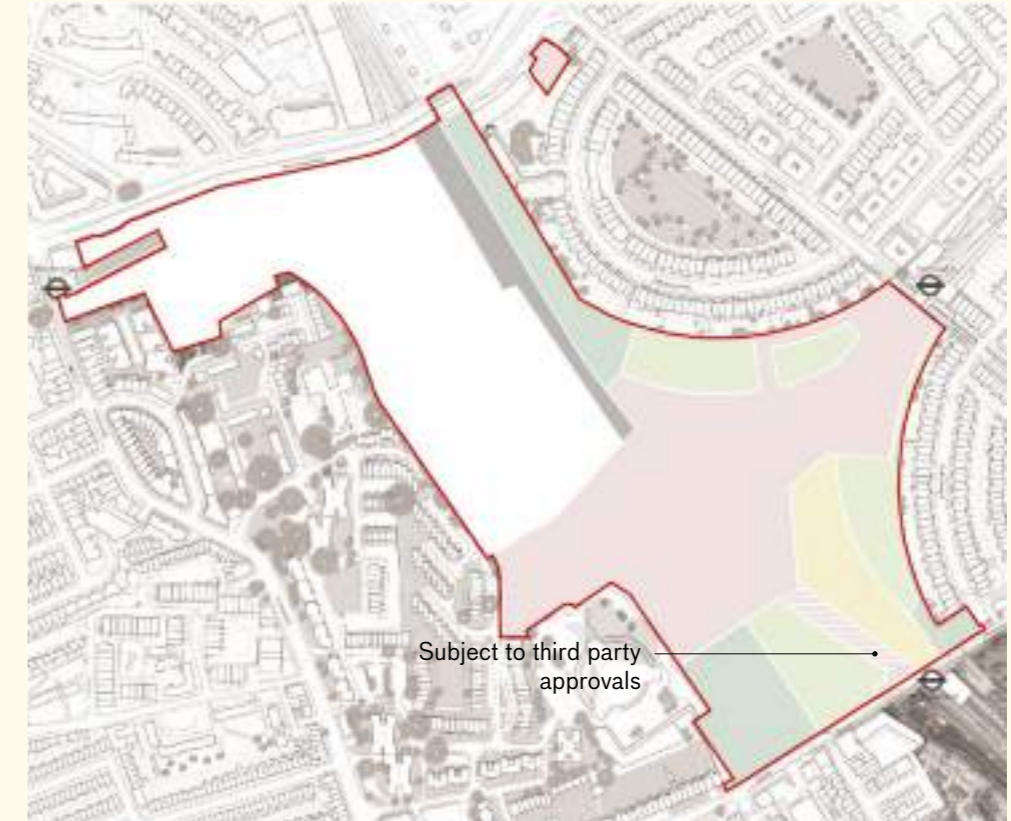

### 2. Early Phases scenario

Phases One to Four (the 'Early Phases') are completed, but the Lillie Bridge Depot remains operational and is delivered to a different programme from that currently anticipated in the All Phases scenario.

# 8.1 Phasing and Delivery

## Indicative phasing sequence



Phase One complete - Q1 2030

Phase One consists of the Detailed Component of the Hybrid Planning Applications and a number of outline Plots subject to later Applications for Reserved Matters Approval. This is anticipated to deliver:

- A mix of residential tenures including affordable housing, build to rent, student accommodation, later living and market sale.
- Commercial, retail, cafés, restaurants and leisure uses.
- Key areas of public realm including Warwick Square, Table Park, the Bioline (subject to third party agreements), the Cascades and Aisgill Gardens (partial delivery).
- East-west connection from the Estates through to Warwick Road.

Phase Two commences construction a year prior to Phase One completion.



Phase Two complete - Q2 2031

Phase Two completes a little over a year later, with three new buildings on West Brompton Crescent. These outline Plots can be delivered as residential or commercial buildings, subject to later Applications for Reserved Matters Approval. This is anticipated to deliver:

- Mix of residential tenures including affordable housing and market sale.
- Commercial uses, retail, cafés and restaurants.
- Key areas of public realm including West Brompton Square and West Brompton Crescent.

Phase Three commences construction once Phase One completes.



Phase Three complete - Q3 2034

Phase Three opens three years after Phase Two and completes both crescents within RBKC, along with the first commercial buildings on Empress Place. It brings with it a cultural destination opening onto the Table Park. This is anticipated to deliver:

- A mix of residential tenures including affordable housing and market sale.
- Commercial uses, retail, cafés and restaurants.
- A cultural destination on Empress Place Boulevard.

Phases Four and Five commence construction before Phase Three completes.



Phase Five complete - Q2 2035

As a shorter phase, Phase Five completes before Phase Four. This brings forward the first buildings within the Lillie Bridge Depot site. This is anticipated to deliver:

- A mix of residential tenures including affordable housing and market sale.
- Community, retail, cafés and restaurants.
- Key areas of public realm including Lillie Sidings Square (partial delivery) and the remainder of Aisgill Gardens.

Phase Four remains under construction for a further two years, and Phase Six begins upon the completion of Phase Five.

Plot(s) under construction



# 8.1 Phasing and Delivery

## Indicative phasing sequence



Phase Four Complete - Q2 2037

Upon completion of Phase Four, all works in RBKC are complete, with the remaining construction within the Lillie Bridge Depot site. This is anticipated to deliver:

- A mix of residential tenures including affordable housing and market sale.
- Completion of the commercial uses on Empress Place Boulevard.
- Key areas of public realm including St Cuthbert's Lane and the remainder of Empress Place Boulevard.

Phase Six remains under construction for a further year and Phase Seven begins at the end of 2037.



Phase Six Complete - Q1 2038

Phase Six sees the completion of Lillie Sidings Square and the adjacent Plots. This is anticipated to deliver:

- A mix of residential tenures including affordable housing and market sale.
- Commercial uses, retail, cafés and restaurants.
- Key areas of public realm including Lillie Sidings Square and connections to Aisgill Avenue.

Phases Seven and Eight begin construction a few months before the completion of Phase Six.



Phase Seven Complete - Q1 2040

Phase Seven consists of the first buildings on West Kensington Boulevard. This is anticipated to deliver:

- A mix of residential tenures including affordable housing and market sale.
- Commercial uses, retail, cafés and restaurants.
- The partial delivery of West Kensington Boulevard.

Phase Eight remains under construction for a further three years after the completion of Phase Seven.



Phase Eight Complete - Q2 2043

The final phase delivers the buildings to the north of the Site. This is a longer phase involving more complex interfaces with rail infrastructure. This is anticipated to deliver:

- A mix of residential tenures including affordable housing and market sale.
- Commercial uses, retail, cafés and restaurants.
- Gibbs Walk connecting the Gibbs Green Estate to West Kensington Boulevard.

Plot(s) under construction

# 8.1 Phasing and Delivery

## Temporary interfaces

Careful attention will be given to temporary interfaces, to ensure the development feels complete at every phase.



Key creative hoarding

Highly visible areas of hoarding provide a canvas to draw inspiration from the Site's cultural legacy and provide a platform to celebrate the work of local artists. The Earls Court Development Company has already recognised the opportunity for creative hoarding with the Living Art Wall on Lillie Road and at Warwick Road Apron which provide a platform to celebrate the work of local artists.



Temporary kiosks and seating

There is potential for temporary kiosks and seating at the interface with construction sites. This could help support Ground Floor uses, such as food and beverage that would benefit from outdoor seating areas.



Temporary site activation opportunity areas

During construction, there will be opportunity areas for temporary uses, prior to development of the Plots. These may front onto the public realm but, depending on the use, may need to have a secure boundary.



Landscaped edges

Temporary landscape can add depth to the interface with construction sites and soften the visual impact of any construction hoarding.

# 8.1 Phasing and Delivery

## Early phases interface

The final element of public realm works for Aisgill Gardens can only be completed once the Lillie Bridge Depot is vacated, allowing Phase Five to be brought forward.

Upon the completion and opening of Phase One, there will be a temporary edge condition with the Lillie Bridge Depot. Until Lillie Bridge Depot is decommissioned, it is necessary to maintain an access route between the Depot and Lillie Road, and the Detailed Component allows for vehicles to use the service road to access the existing gate at the south of the depot. This access is infrequent and will be managed to mitigate impact on the public realm and the new buildings.

The detailed design for Aisgill Gardens will allow for it only being delivered in full when Phase Five completes. Once vacant possession has occurred, the construction hoarding can be moved back to the Depot boundary. As a result, areas of temporary landscaping will interface with the construction hoarding, until Aisgill Gardens can be completed in full.



Temporary interface with Lillie Bridge Depot



View looking east with Aisgill Gardens partially complete



Celebrating local artists on Warwick Road Apron



## 8.1 Phasing and Delivery

### Estate management

An estate management structure will be set up to ensure the long-term success of the development, through continued establishment and engagement with the community.

#### Estate management structure

An Estate Management Company (EMC) will manage the public realm elements of the Estate, including the soft landscaping components and park areas.

Each Plot will have its own Plot Management Company (PMC). Each PMC will be controlled by the Leasehold owners of the new homes, the Registered Provider (or other management body for affordable homes) if they have units within the Plot and the Leasehold owners of the retail spaces within the Plot.

#### Estate management facilities

An on-site Estate Management Office will be located within Phase One. This will provide all residents with direct access to the range of services on offer from the EMC, PMCs and their partner bodies, including the Registered Provider's Tenancy and Leasehold Management services. The office will be a focal point within the Proposed Development and act as the hub from where all key activities and services flow.

The central Estate Management Office will provide a shared front of house reception, staffed by administrators who are paid for jointly by those organisations using this facility. Front of house will deal with all enquiries and channel them through to the appropriate teams, presenting a joined-up service to all customers entering the Estate.

### Community development and engagement

People living and working in the immediate vicinity of the Estate, as well as new communities that will move in, will be critical to the long-term success of the Proposed Development. It is essential that the community is engaged throughout the development process and that they play a central role in the ongoing management of the Estate. In addition to ongoing engagement, the following key considerations for estate management will contribute to successful community development and integration:

Informed public - For all those passing through, visiting, working or living in the Proposed Development, the EMC team will ensure information is readily available. Communication will be through an up-to-date website, information points and well informed staff.

Informed occupiers - The EMC team will ensure that all owners and occupiers are well informed of EMC processes and activities.



Potential location of the Estate Management Office

Integrated Estate - The EMC team will be open and responsive to new ideas, monitoring activities elsewhere and benchmarking against performance of other Estates and neighbourhoods.

# 9 Conclusion

# EARLS COURT

Setting the standard for future urban development, Earls Court will re-emerge as London's place to discover wonder.





Responding to its role within the Earl's Court and West Kensington Opportunity Area, the Proposed Development delivers homes, jobs, culture, leisure and public realm, with an ambition to be a global exemplar of sustainability.

The designation of the Site as an Opportunity Area by the Mayor of London signifies the importance of Earls Court in delivering the good growth that London and the UK needs, accommodating living and working populations in well-designed, inclusive communities.

Social impact, economic prosperity and environmental resilience underpin the Proposed Development, creating a place for the 22nd Century with a unique cultural identity.

The proposed Earls Court Development is based on an illustrative masterplan which will reinstate this iconic site of human ingenuity as a fundamental part of London's urban fabric.



From the outset, a fresh approach was taken to understanding the Site and to inform the evolution of the proposals.

The Earls Court masterplan has been shaped by extensive engagement and outreach into the local community.

Over the past four years, ECDC and the design team have taken a relentlessly inclusive approach to consultation. Spending thousands of hours in dialogue with members of the community, including a core focus on seldom heard voices, has had a clear impact on the masterplan. The outcomes of this process has embedded the voices of local people in the evolution of the proposed masterplan.



ECDC has brought the Site back to life through an early activation programme, opening it up for the first time in 150 years, bringing arts, entertainment, culture and innovation.

Attracting around 500,000 visitors, this has generated investment in the local economy and re-established Earls Court as a destination. This has deepened the understanding of the Site, its context and the extraordinary opportunity it presents.



Earls Court will be a better piece of city, a place where living, working, culture, leisure and open space are brought together in a landscape-led development with consideration for diverse needs and aspirations.



The masterplan is a carefully crafted response to local heritage and townscape considerations. It has drawn from its context to establish a place that knits into the existing local environment adding a contemporary layer that contributes positively to the urban streetscape.



Sustainability underpins the masterplan, addressing the climate emergency through urban design and the integration of new technologies – not simply minimising impact but promoting a resilient and regenerative agenda.

The masterplan strives for design excellence by:



Establishing a new west side story and creating a destination in this part of London.



Creating an Earls Court for everyone through a neighbourhood which brings people together.



Being good ancestors by thinking beyond today, delivering the ambition to create the heritage of the future.

## Earls Court will be a celebration of nature's ability to connect and revive.

Nature presents untold benefits to the health and wellbeing of ourselves and our planet. Amplifying its presence and fostering better connections with nature is our golden thread - creating diverse and generous spaces to play, meet, relax and for sanctuary, whatever the season.

The Earls Court Development will consist of a network of Exhibition Gardens set within 20 acres of public realm, curating a journey of discovery across the Site and providing a wide variety of habitats, activities and environments for people of all ages and abilities to enjoy.



## Earls Court will be a showcase for climate and clean innovation and skills.

A new destination will offer the scale, location and connectivity to create a home for a green economy, accelerating opportunities in a smart campus environment that supports start ups, scale ups and multi nationals to collaborate and tackle humanity's challenges.

The Earls Court Development will deliver 2.5 million sq ft of workspace across three clusters, working with partners to equip the next generation with vital skills and generating 12,000 jobs on site.



# Earls Court will be a cultural ecosystem for the future of talent.

Earls Court is synonymous with the power of culture, creativity and performance with a magnificent heritage of spectacle dating back to the 19th Century. The spirit of delight and discovery is re-emerging as the Site once again is proudly stitched back into London's cultural map.

Three anchor venues, alongside flexible spaces, shops, cafés and seasonal outdoor events, will attract creative businesses and operators to Earls Court.



# Earls Court will be an inspiring neighbourhood designed for all stages of life.

Earls Court will exemplify the future of city living, creating a new urban fabric, a place where people want to visit but also stay and grow, whether to live or work. Reflecting the brilliance of London, Earls Court will be inclusive and accessible, allowing families, communities, businesses and social connections to take root and thrive.



Earls Court has always been a unique part of the city, at the forefront of historic, economic and societal change.

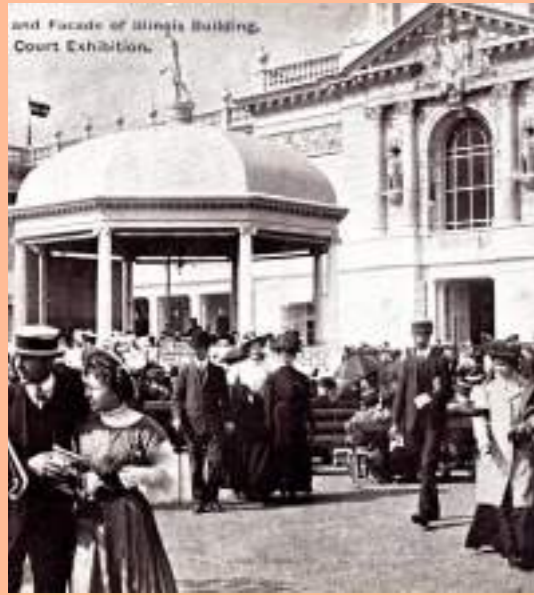

This is a once in a lifetime opportunity to bring the wonder back to Earls Court, restoring it as an extraordinary place to London's landscape, bringing best practice from around the world, relating that to the locality of Earls Court and changing the way people experience a place.



This will be Earls Court.



# 10 Appendices



# 10.1 Neighbourhood Characterisation

## A varied neighbourhood context

The wards that surround the Earls Court Site display a rich social and physical context made up of a varied housing stock with a range of retail offerings and local destinations.

The following pages summarise an analysis of the context and demographic makeup of the six wards surrounding the Site. This analysis was carried out at the outset of the masterplan development, and has informed its evolution.

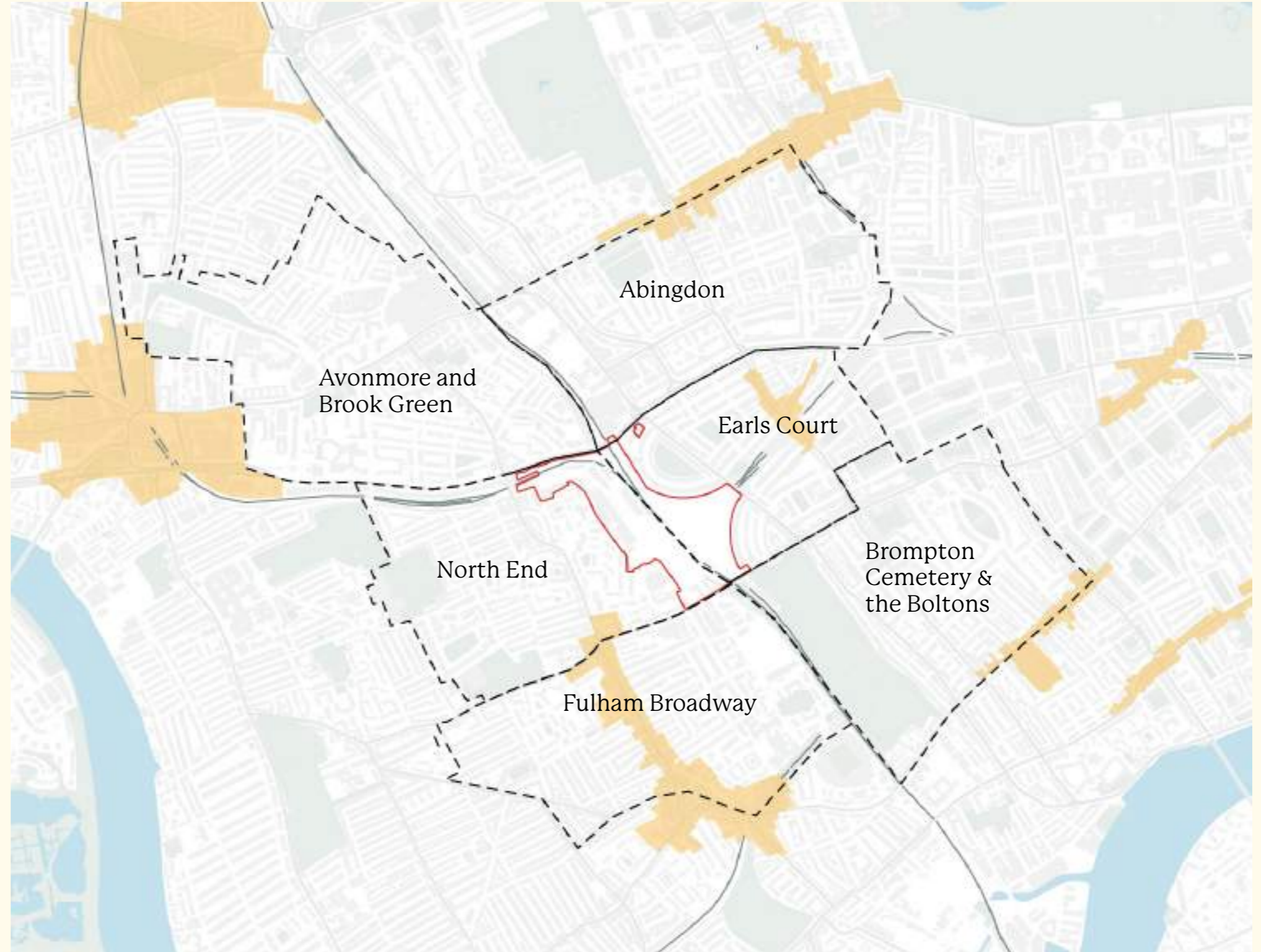

The six wards that surround the Site



# 10.1 Neighbourhood Characterisation



## Avonmore and Brook Green

The ward of Avonmore and Brook Green is located north of the Site and is bound by West Cromwell Road to the south and the West London Railway Line to the east.

Kensington High Street and North End Road are the two main high streets in the area, with a high concentration of shops. Olympia and Hammersmith Town Centre is within easy reach.

The ward is home to the Olympia exhibition centre, West London College and Society for Psychical Research. There is additionally a cluster of media and tech businesses located in Kensington Village along the West London Railway Line.

The neighbourhoods either side of North End Road are mostly residential with a mix of terrace houses and mansion blocks, and also include a preparatory and primary school.

Infrastructure creates a significant barrier to connectivity to other wards, with only the north boundary being open to the surroundings.

The ward is served by Transport for London (TfL) Underground services at West Kensington and Barons Court, and the Overground at Kensington Olympia.

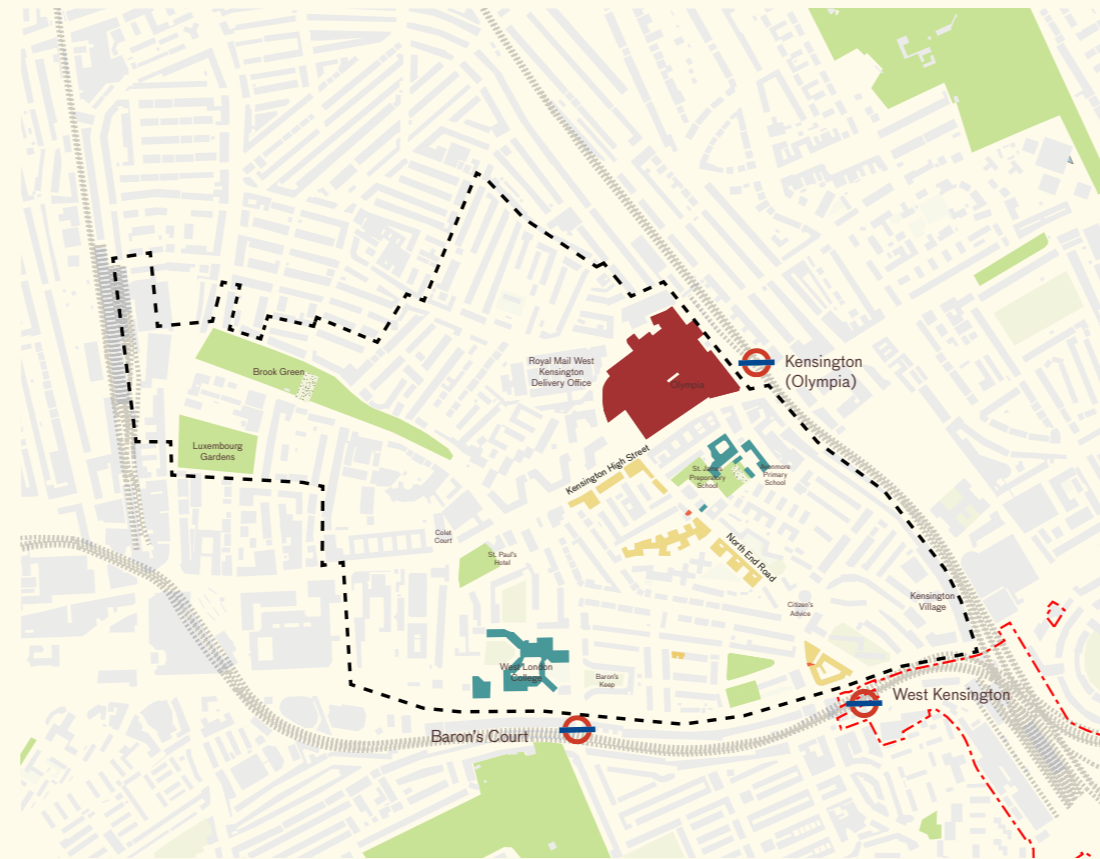

Avonmore and Brook Green ward



Olympia Exhibition Centre



Baron's Keep, Art Deco apartments



West London College



Kensington Village



St Paul's Hotel

- |                   |                     |
|-------------------|---------------------|
| Ward boundary     | GP / Health centre  |
| High street       | Sports facility     |
| Retail            | Leisure and culture |
| Public open space | Major destination   |
| Playground        | Hotel               |
| School            | Places of worship   |



# 10.1 Neighbourhood Characterisation



## North End

The North End ward includes the portion of the Site that sits with LBHF. It extends to the Gibbs Green and West Kensington Estates, and beyond. It is bound by the A4 to the north and Lillie Road to the south. North End Road runs through the area, providing access to local shops and services.

The North End Road community is international, particularly within the Estates, with a large number of people born outside of the UK, many of whom may not speak English as their first language..

A high number of local cultural institutions and sports and leisure facilities create the opportunity to celebrate the cultural diversity of the area.

This ward's population relies heavily on public transport as car ownership is relatively low. This suggests that the local community would benefit from enhanced access to Underground, Overground and Network Rail stations, as well as improved walking and cycling routes.

Future development within the Site has a role to play in creating a seamless integration with the Estates and neighbourhoods to the west.



North End ward



North End Road

- Ward boundary
- High street
- Retail
- Public open space
- Playground
- School
- GP / Health centre
- Sports facility
- Leisure and culture
- Major destination
- Hotel
- Places of worship



West Kensington Estate



Normand Park



Arthill Art Gallery



Queens Club



Margravine Cemetery



# 10.1 Neighbourhood Characterisation



## Fulham Broadway

Fulham Broadway is located south of the Site and is bound by the West London Railway Line to the east, Lillie Road to the north and Fulham Broadway to the south.

Residents of this area have good access to convenience retail, services, and public transport, and enjoy the amenity of two high streets at North End Road and Fulham Broadway.

Residents are likely use of new open spaces at Earls Court due to the limited number of local parks in the area. They are also likely to benefit from any potential cultural offerings at Earls Court, especially if links can be created with the London Film Academy and the West London Arts School.

The high proportion of self-employed people in this area suggests that co-working and start-up space at Earls Court could offer benefits to Fulham Broadway residents.

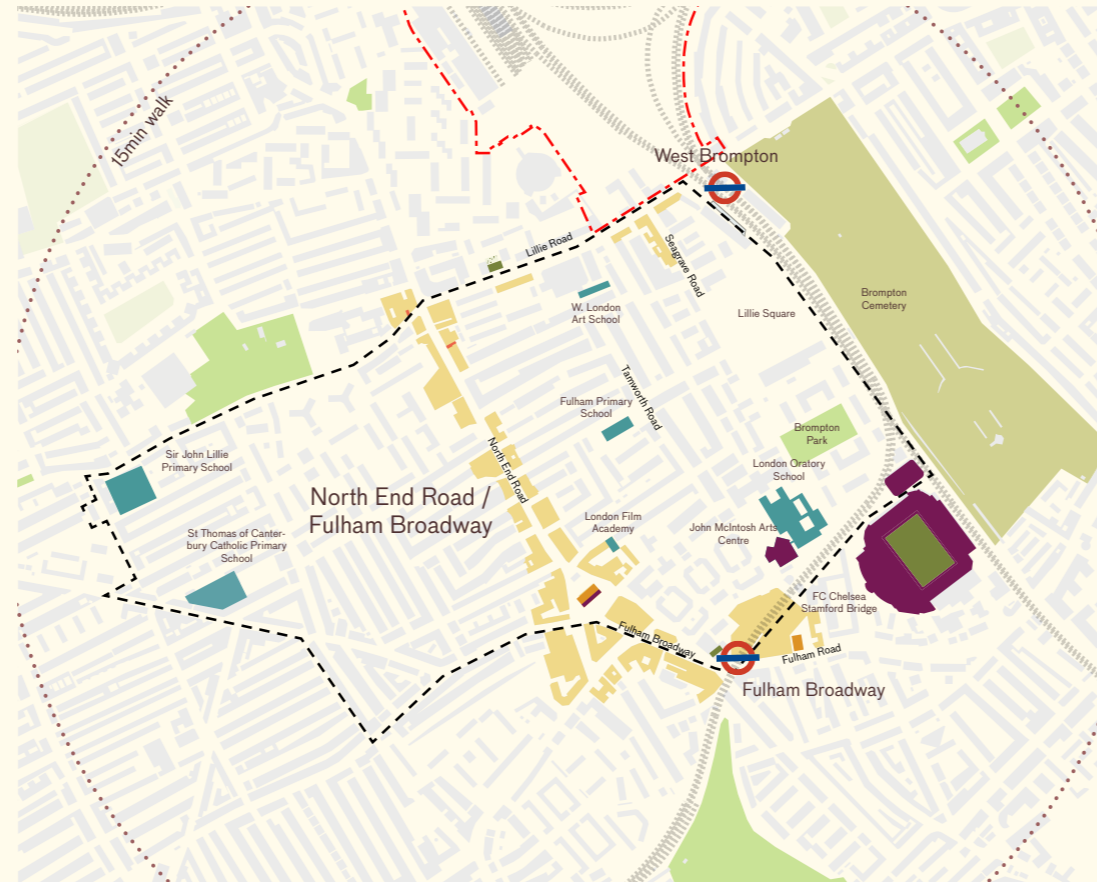

Fulham Broadway ward



Brompton Park



Stamford Bridge



Lillie Square



Fulham Broadway



Lillie Road

- Ward boundary
- High street
- Retail
- Public open space
- Playground
- School
- GP / Health centre
- Sports facility
- Leisure and culture
- Major destination
- Hotel
- Places of worship



# 10.1 Neighbourhood Characterisation

## Abingdon

Abingdon is located to the northeast of the Site and is bounded by West Cromwell Road to the south and Kensington High Street to the north. Residents benefit from convenience shops along Kensington High Street, the large Tesco on West Cromwell Road, and few other shops and services in the area.

Good walking and cycling links into the Site would benefit the wider community and provide improved connectivity across all wards. There is significant new development coming forward in parts of Abingdon. This provides a precedent for growth and contemporary development in the local area.

A shortage of public open space within the ward means that its community would benefit from any new significant public open space at Earls Court.

The community in Abingdon has easy access to Earls Court and Earls Court station, and is not likely to use the Site to connect to West Kensington station for public transport purposes.

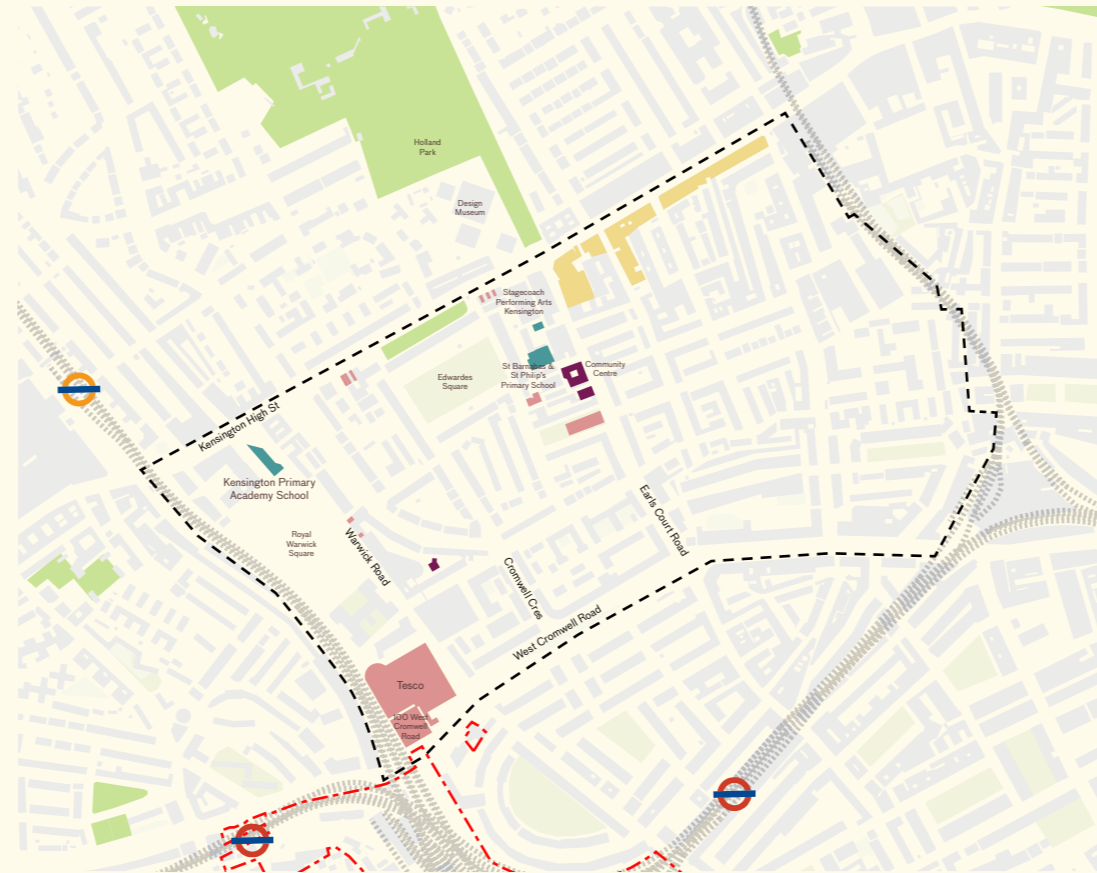

Abingdon ward



Edward House, Royal Warwick Square



High Street Kensington



Edwardes Square



375 Kensington High Street, Royal Warwick Square



Tesco on West Cromwell Road



100 West Cromwell Road, ©John McAslan + Partners

- Ward boundary
- High street
- Retail
- Public open space
- Playground
- School
- GP / Health centre
- Sports facility
- Leisure and culture
- Major destination
- Hotel
- Places of worship



# 10.1 Neighbourhood Characterisation



## Earls Court

The Earls Court ward includes the portion of the Site that is within RBKC. It extend east and is bound by Earls Court Road and Courtfield Gardens. West Cromwell Road and Old Brompton Road form the northern and southern edges to the ward. Residents of this area have good access to everyday shops, services, and public transport, with Earls Court Road and Warwick Road running through the area.

There is a lack of public open space in this neighbourhood, so residents who do not have access to private gardens will benefit from any new public open space on the Site.

There is a high percentage of young professionals, most of whom are currently renting in the area, and some of whom may be looking for an opportunity to purchase a home at Earls Court. Many of these professionals work long hours in high-skilled jobs and are likely to make use of leisure, cultural, and food & beverage offerings in the evenings and on weekends.

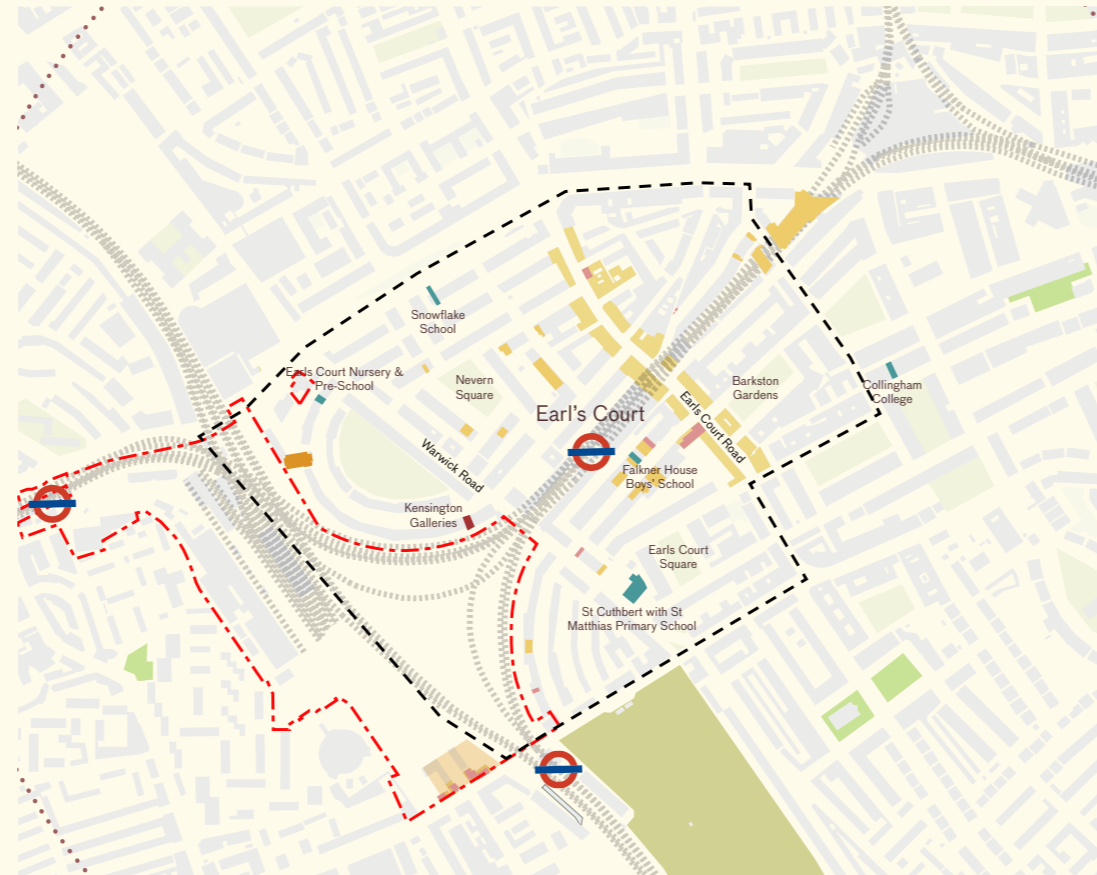

Earls Court



Earls Court Square



Nevern Square



Penywern Road



Earls Court Road



Earls Court station

- Ward boundary
- High street
- Retail
- Public open space
- Playground
- School
- GP / Health centre
- Sports facility
- Leisure and culture
- Major destination
- Hotel
- Places of worship



# 10.1 Neighbourhood Characterisation

## Brompton Cemetery and the Boltons

The Redcliffe ward, which comprises Brompton Cemetery and the Boltons, is located to the southeast of the Site. The area is bound by Brompton Cemetery on the west, Fulham Road on the south and Old Brompton Road to the north.

Residents of this area have easy access to the open space within Brompton Cemetery, although they would benefit from access to public open space that provides a more varied use within the public realm.

Residents have easy access to Earls Court and Earls Court station, and are not likely to use the Site to connect to West Kensington station for public transport purposes. Active uses at the edges of the Site would help stitch the north-western part of the ward into the Site and help complete the setting of Old Brompton and Lillie Road.

A large proportion of owner-occupiers in this ward suggest a long-term interest in the future of the area, especially as regards value-generating propositions like an innovative new working district, destination public realm and an extension of the cultural ecosystem of West London.

- Ward boundary
- High street
- Retail
- Public open space
- Playground
- School
- GP / Health centre
- Sports facility
- Leisure and culture
- Major destination
- Hotel
- Places of worship

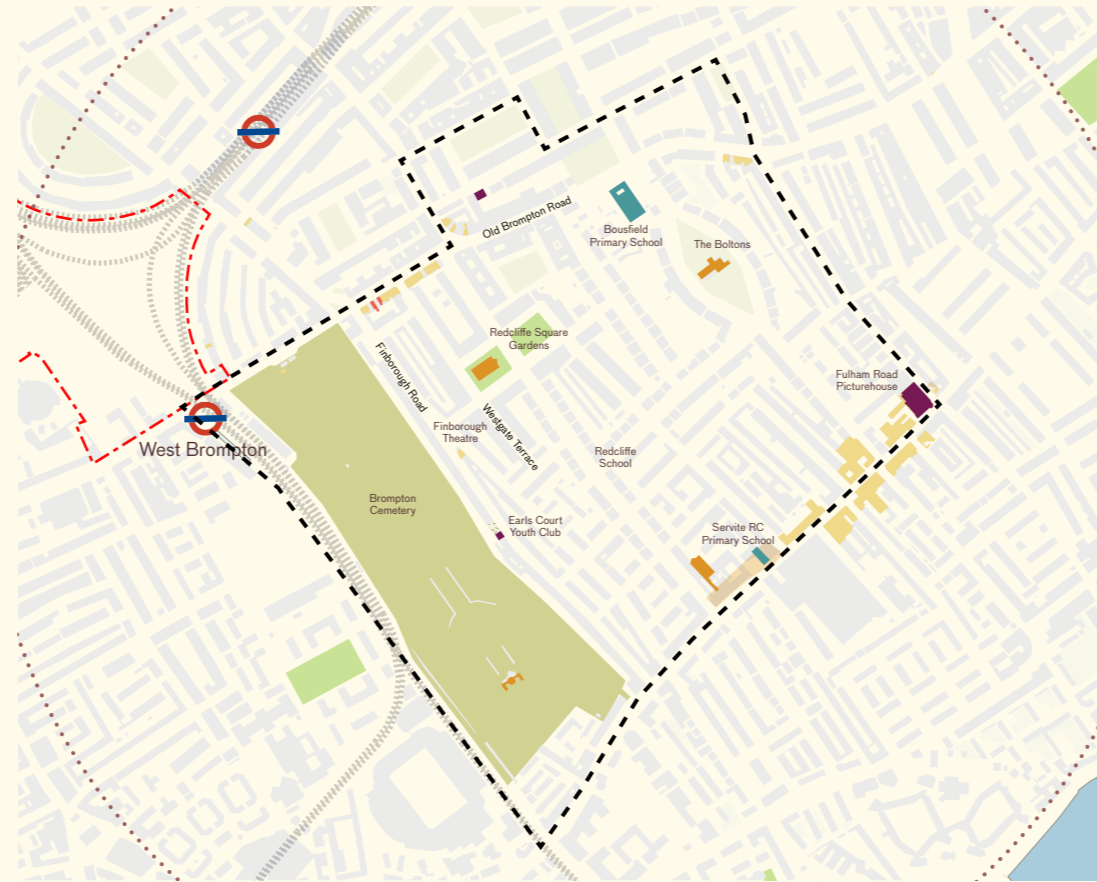

Brompton Cemetery and the Boltons



Redcliffe Square



St Mary's Church, the Boltons



Brompton Cemetery



Brompton Cemetery, Lillie Road



The Boltons







# 10.1 Neighbourhood Characterisation

## Walking routes

Earls Court today continues to be a confluence of many characters and journeys.

West London is diverse, a patchwork of streets, crescents, and urban set-pieces that contain a mixture of quality legacy buildings, post-war blocks, and landmarks. While there are a number of walking routes in the local area, there is a missing link in these journeys due to the current Site and rail infrastructure. The Earls Court Development is a major missing link that brings together the varied spatial experiences of each route into a coherent public realm network.

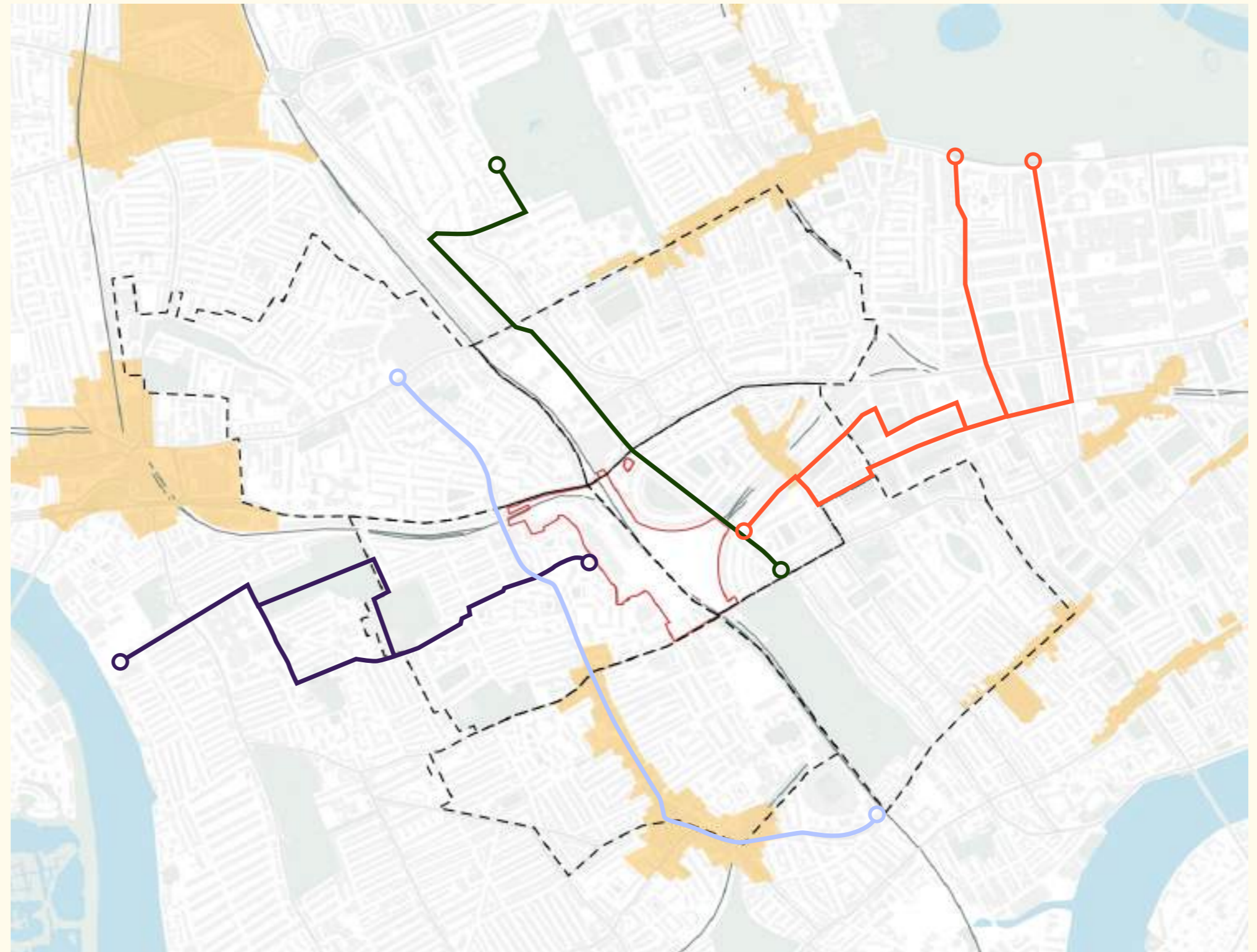

- Earls Court to Hyde Park & Museum Quarter
- Earls Court to Fulham Reach
- Olympia to Chelsea Harbour
- Holland Park to Old Brompton Road



# 10.1 Neighbourhood Characterisation

## Walking routes: Along Warwick Road - a green to blue network

From Holland Park, to Earls Court, to Brompton Cemetery and the Thames

100 West Cromwell Road, ©John McAslan + Partners



Ibis Hotel

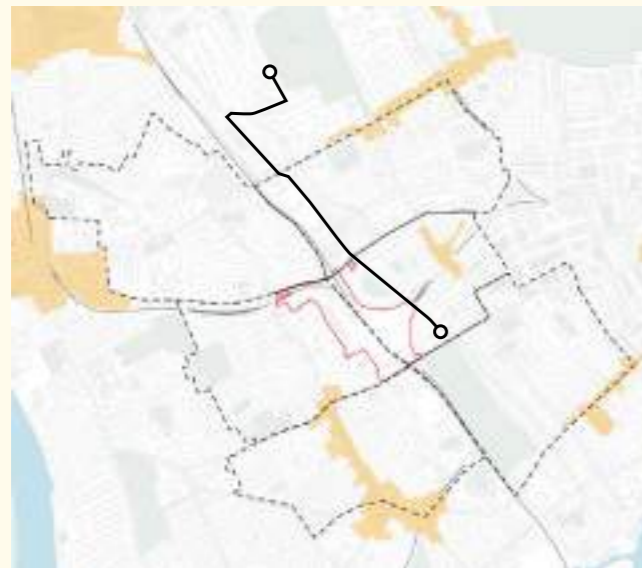

- Key nodes and intersections
- Important buildings and taller landmarks
- New and recent developments

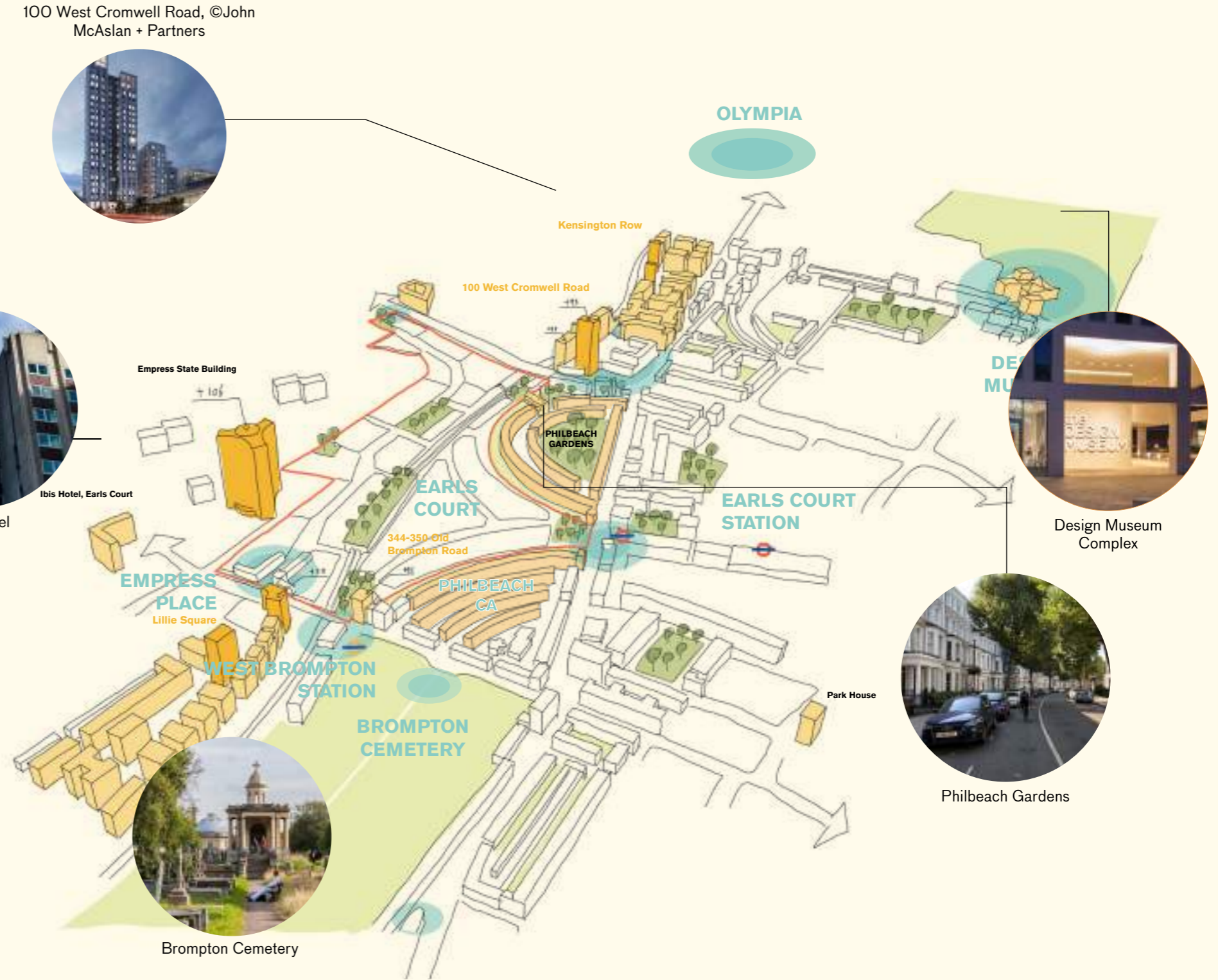

Brompton Cemetery



Design Museum Complex



Philbeach Gardens



# 10.1 Neighbourhood Characterisation

## Walking routes: Towards Fulham Reach, a quiet network to the Thames

From post-war construction to the Queens Club and Margravine Cemetery

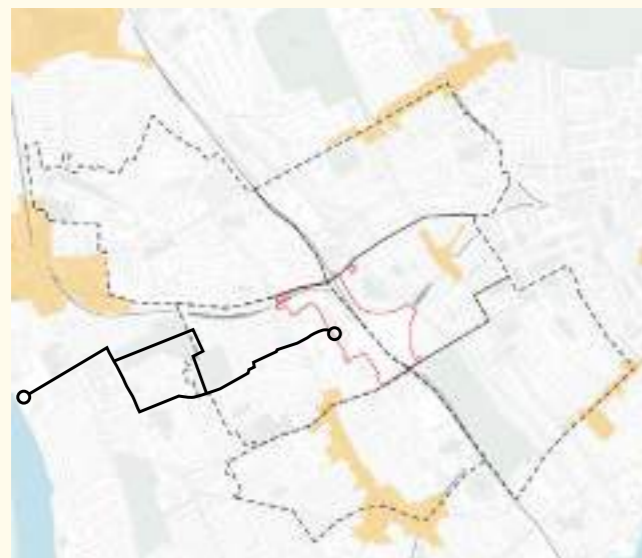

- Key nodes and intersections
- Important buildings and taller landmarks
- New and recent developments

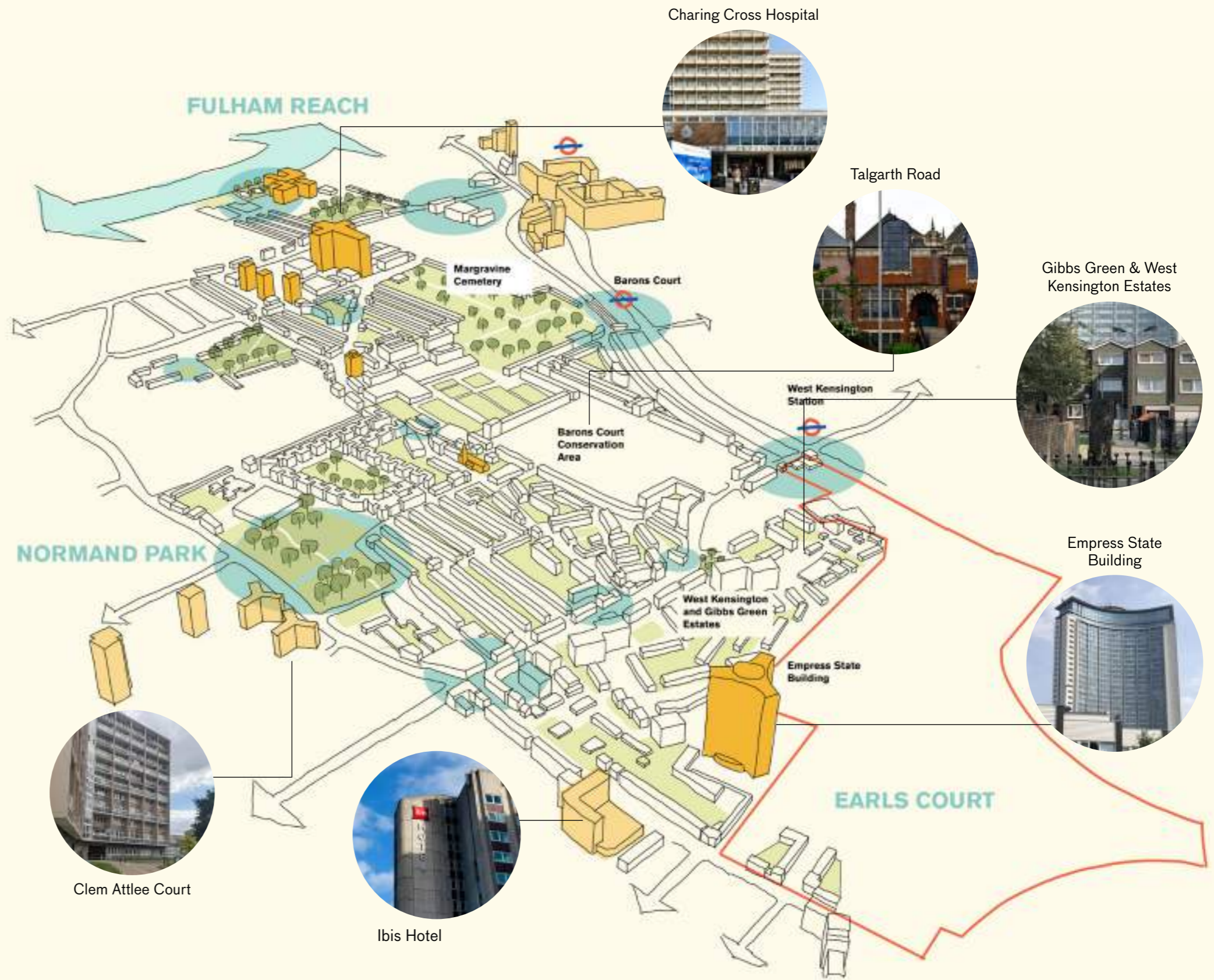



# 10.1 Neighbourhood Characterisation

Walking routes: Along North End Road, through high streets from Olympia to Chelsea

Punctuated by nodes of commercial character



- Key nodes and intersections
- Important buildings and taller landmarks
- New and recent developments





# 10.2 Sitewide Lighting Strategy

## Introduction

Nature, culture, innovation, and neighbourhood are the four place pillars that underpin the vision for Earls Court, and lighting will play a part in celebrating each of these after dark.

A mix of business, leisure, civic, retail, cultural, sporting, and social activities all form part of any area's character, and the way in which light is designed across an area will enable, encourage, and shape that character. Different spaces require different layers of light to enable and encourage their functions. From quiet residential streets to busy cultural venues, a range of different lit atmospheres will be required across the Site. These lit atmospheres will also need to change over time in accordance with the varying demands of the spaces and their users at the different times of the night and across seasons.

As well as enabling human activity, artificial light after dark has an impact on the ecosystems of any space. A key principle of the lighting strategy is that light levels are controlled to minimise any negative impacts on plants, insects, and other animals.



Lillie Sidings Square: Illustration of how lighting design can bring the square and activity to life after dark



# 10.2 Sitewide Lighting Strategy

## Design Criteria

A balance of several criteria forms the overall approach to light across the masterplan.

Design Criteria that form the overall balance of the lighting scheme include:

- Sustainability (social, environmental, economic)
- Safety & Security
- Memory
- Character
- Image & Branding
- Ambience
- Legibility
- Context (visual, spatial, historic)
- Technology (current and future)
- Amenity
- Cost (capital and running)
- Accessibility
- Maintenance



Diagram illustrating the multiple criteria that is integrated within the lighting strategy



# 10.2 Sitewide Lighting Strategy

## Character Areas

Different lighting characteristics are proposed, appropriate to the functions and users of the various spaces across the masterplan.

A variety of luminaire specifications, locations, mounting types, and control systems will be proposed to create each of the different atmospheres suitable for their Character Areas and the typologies of routes and spaces within them.

The key spaces and streets are summarised below:

### Park

- The Table Park

### Squares and greens

- Aisgill Gardens
- Lillie Sidings Square
- West Brompton Square
- Warwick Square

### Commercial and mixed-use streets

- West Brompton Crescent
- West Kensington Boulevard
- Empress Place Boulevard

### Residential areas

- Warwick Crescent
- West Brompton and Warwick Lanes
- Aisgill Lanes



Illustrative evening view of West Kensington Boulevard



Illustrative evening view of Aisgill Gardens



Illustrative evening view of West Brompton Crescent



Illustrative evening view of Empress Place Boulevard



# 10.2 Sitewide Lighting Strategy

## Lighting Control

The lit atmospheres across the Site will change over time, providing appropriate lighting to ensure safety and legibility for people using the different spaces, and suitable for the different intensities of activity expected through the night.

Through darker, quieter periods, light intensities will dim down, and colour temperatures will shift to warmer tones to reduce negative impacts on wildlife. An additional layer of flexibility for the lighting of the Site is proposed through consideration for special events and temporary lighting.



Early evening	Pre-dawn	Overnight	Late evening	Dawn
2,700K	2,500K	2,200K	2,500K	2,700K
100% Intensity	75% Intensity	75% Intensity	75% Intensity	100% Intensity

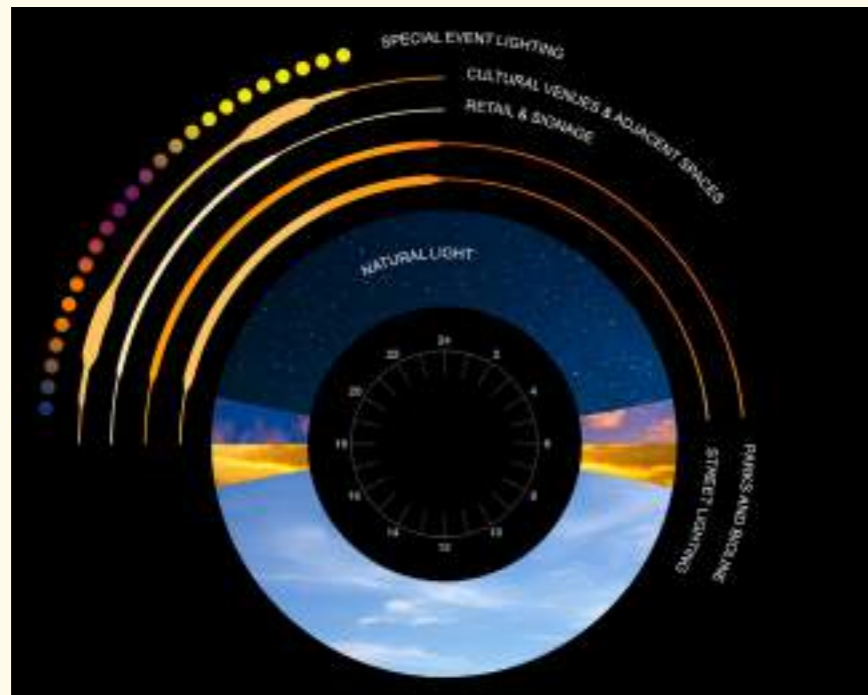

Change of late layers over time



Colour temperatures - early evening



Colour temperatures - overnight





# 10.2 Sitewide Lighting Strategy

## Environmental Zones

Environmental Zones restrict light pollution within the masterplan, between neighbours, and into the sky.

The current proposals for Environmental Zones varies across the Site, between E2 along wildlife corridors, E3 as the default across the Site, and E4 at the busier site entrances.

- Environmental Zones
- E4
  - E3
  - E2

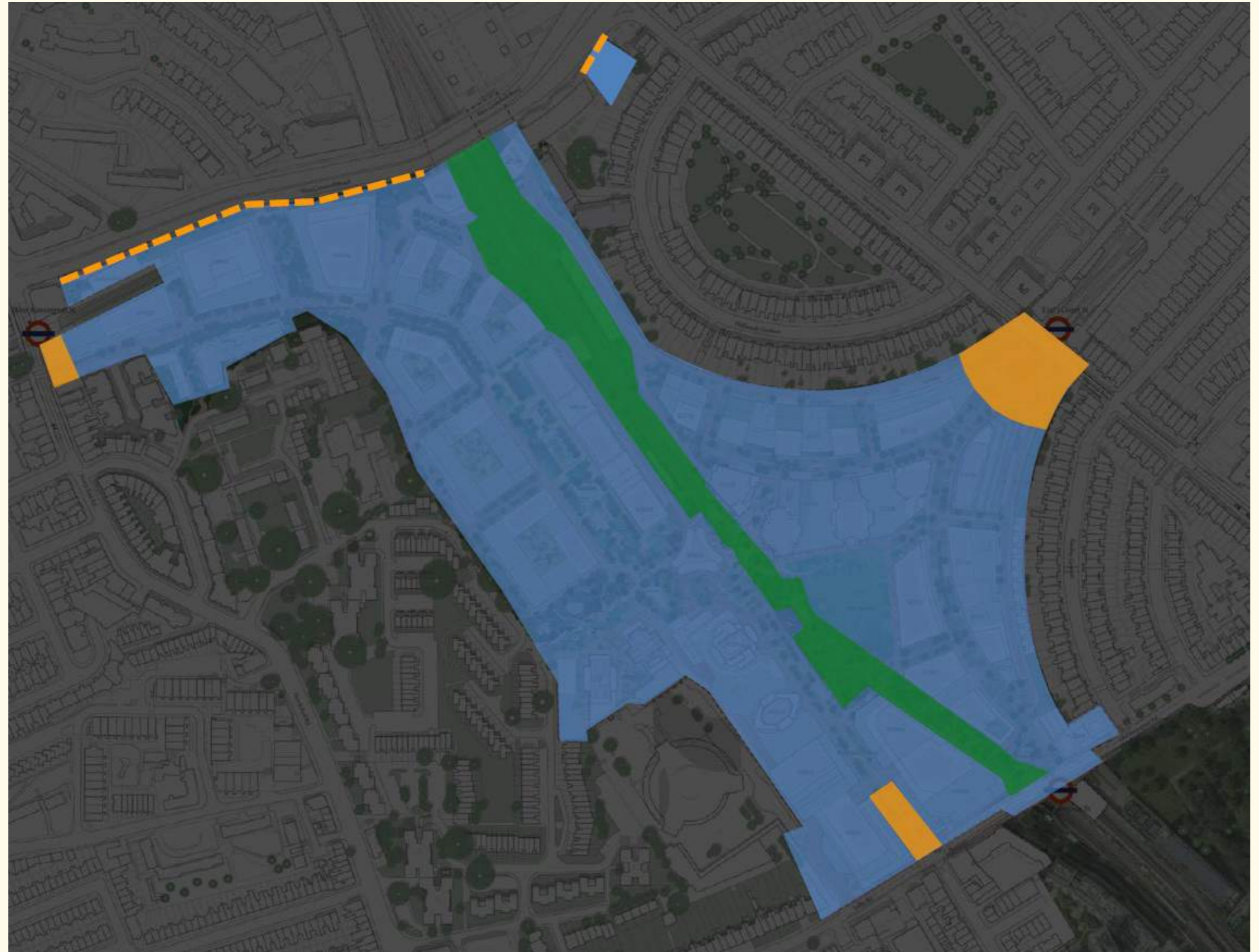

Lighting strategy diagram illustrating Environmental Zones



# 10.2 Sitewide Lighting Strategy

## Lighting Standards

Standards are proposed for all routes across the site, and it is proposed that every route will step down to a lower light intensity through quieter overnight periods.

- Route Standards
- P5  
Eav: 3 lux
  - P4  
Eav: 5 lux
  - P3  
Eav: 7.5 lux
  - P2  
Eav: 10 lux
  - P1  
Eav: 15 lux
  - M2  
L: 1.50 cd/m<sup>2</sup>
  - M1  
L: 2.00 cd/m<sup>2</sup>



Route Standards - early evening



Route Standards - overnight

# 10.3 RBKC Placemaking Framework Tracker

## Introduction

### RBKC SPD context

This section provides an overview of the relationship of the Hybrid Planning Applications for the Earls Court Development in the context of the RBKC SPD (“Earl’s Court Opportunity Area Placemaking Framework”, April 2023).

With a particular focus on the areas of the masterplan located within the Royal Borough of Kensington and Chelsea (RBKC), the following pages present a summary of the response of the masterplan to the core objectives of this Supplementary Planning Document (SPD).

The Earl’s Court and West Kensington Opportunity Area straddles the RBKC and the London Borough of Hammersmith and Fulham (LBHF), borough boundary. The RBKC SPD aims to:

“Support an ambitious transformation for the Opportunity Area to become a lively new part of the wider neighbourhood, focusing on the part of the site which lies within Kensington and Chelsea”, p.3.



### SPD framework

The SPD is organised around four placemaking priorities for the RBKC site allocation (aspirations that then form the basis of the emerging Local Plan site allocation). The four placemaking priorities distil the aspirations identified for the Site, which are summarised in the adjacent extract:

“The Opportunity Area should become a lively, new urban quarter of cultural, employment and residential uses that is innovative, sustainable and integrated with the surrounding neighbourhood”, p.11.

The design evolution of the Earls Court Development has coincided with the preparation and adoption of this SPD. ECDC and the Design Team attended engaged with RBKC during 2022 and contributed to the shaping of the priorities for the Site.

As such, the ambitions and objectives expressed in the SPD framework reflect many of the shared objectives for the Site - that have been further refined through the wider stakeholder engagement and statutory consultation and Site optimisation as described in Chapter 4 of this DAS.

For reference, the four priorities of the SPD framework are summarised on the following page with the associated diagrammatic explanation. This is then followed by a table summarising the key policy objectives of each priority and the scheme provision and/or response to these objectives.



Extract from the Earl's Court Opportunity Area Placemaking Framework SPD (p.11)

Identifying the summary of the key placemaking priorities that structure the document. The following pages use these themes to provide an illustration of how the Earls Court Development has responded to these objectives and to provide a reference checklist to support the interpretation of the application in this context.



# 10.3 RBKC Placemaking Framework Tracker

## SPD priorities



### Priority 1: Public realm first

“The landscape strategy should provide people with a variety of generous, functional and attractive streets and spaces characterised by substantial trees and urban greening. Open space with a neighbourhood character to meet the needs of new residents and the local community is crucial. The public realm should lead the development, with the scale, design and use of buildings complementing and enhancing its various characters and functions: landscape and people before buildings”, p.13.



### Priority 2: Exemplar of environmental sustainability

“An ambitious and innovative approach to the challenges of climate change should underpin all scales and dimensions of the development in a manner that is holistic, goes beyond base policy and regulatory requirements at approval and implementation stages, and is resilient for the future. Thinking about the whole lifetime of the development, a meaningful and informative way to track the scheme’s performance against a comprehensive sustainability charter should be devised”, p.17.



### Priority 3: Part of the city

“The development should seamlessly continue the city by using a street-based layout informed by a sophisticated understanding of local and London street patterns, including how the scheme stitches into Warwick Road. The wider gap in the townscape here should accommodate a re-imagined London square, providing a green oasis. A sensitive integration of building scale is needed across the scheme, with greater care in the design of buildings over 10 storeys, given their greater visibility and environmental impacts.”, p.21.



### Priority 4: Varied and rich urban life

“The cultural offer should give Earl’s Court a distinct identity, attracting visitors and related new and local ventures. Culture should be tangible and visible, spilling out into principal public spaces, while all other uses on the site should maximise their contribution to a delightful and varied public realm. This new part of the Earl’s Court neighbourhood should be somewhere people want to live and settle; day-to-day life should be convenient and comfortable, with the new buildings, streets and spaces designed to cultivate a sense of community and belonging.”, p.27.



# 10.3 RBKC Placemaking Framework Tracker



## Priority 1: Public realm first

Policy scope	Policy requirement	Scheme provision / response
1.1 Landscape before buildings	"a) Let the landscape lead The landscape plan should be the base and starting point of the masterplan, setting out priorities for public realm and landscape early on the design process."	<p>Many of the fundamental design principles that have shaped the masterplan are focused around landscape. These landscape led principles include opening up new routes across the Site, stitching into the wider context with arrival squares and streets, creating a park at the centre of the Site (located around retained features), and the definition of a varied streetscape, all of which underpin the spatial strategies and vision for the Site. A public realm framework has been established prior to considering the extent and locations of building Plots, allowing themes of nature, water and play to be integrated into the design.</p> <p>Refer to DAS Chapters 5, 6 and 7 (EC.PA.08), and associated sitewide strategies in the Design Code (EC.PA.C).</p>
	"b) Working with the site The site's levels, existing habitats, existing structures (such as the West London Line deck, the steps on the Warwick Road Apron and St Cuthbert's Church as a key neighbour) should be integrated creatively into the scheme."	<p>Existing habitats have helped to inform the location and design of key open spaces which help to reconnect an existing north-south ecological corridor. This has been reinforced by the generously planted design of West Brompton Square and the Bioline, which is subject to third party agreement.</p> <p>The existing West London Railway Line, the Sites of Importance for Nature Conservation (SINCs) along it, and the Table Structure have defined the location of the key open space - the Table Park. The former Exhibition Centres steps have inspired the planted amphitheatre of the proposed Warwick Square.</p> <p>The street layout along St Cuthbert's Lane is purposefully pulled away from St Cuthbert's Church to retain the planted bank which forms part of its setting. A potential connection from St Cuthbert's Lane to Cluny Mews has been enabled and is subject to third party land ownership.</p> <p>The Site's existing level change has informed the design of the Cascades, which creates a stepped landscape that celebrates water use and retention.</p> <p>Refer to DAS Chapter 6 and 7 and associated sitewide strategies in the Design Code (EC.PA.C).</p>
	"c) The West London Line deck The West London Line deck will form a characterful and distinctive new park connecting the two parts of the Opportunity Area. Its design should celebrate and express its history as part of the site's infrastructure heritage and should provide significant green spaces as well as harder landscape where activities can be programmed."	<p>At the centre of the masterplan is the Table Park, which is the largest green open space within the proposals. It is located above the West London Railway Line deck (the Table Structure), which connects both boroughs. The Table Park is predominantly a green space, but also has active edges, lawn spaces for picnics and informal sports, two destination play spaces and a variety of formal and informal pedestrian and cycle routes. The western side of the Table Park addresses the level change by forming a clearly defined edge that frames Empress Place Boulevard below. The level change provides an opportunity to incorporate active uses along the edge that creates spaces inspired by railway arches that express and celebrate the Site's infrastructure heritage.</p>



# 10.3 RBKC Placemaking Framework Tracker



## Priority 1: Public realm first (continued)

Policy scope	Policy requirement	Scheme provision / response
1.2 Working with natural systems and the inherited landscape	"a) Maximise biodiversity Ecological habitats should be strengthened and connected via green corridors and opportunities to maximise biodiversity and ensure climate resilience of planting should be demonstrated."	The existing ecological corridor either side of the Table Structure along the West London Railway Line will be enhanced and strengthened through diverse and resilient planting at the Table Park, Bioline and West Brompton Square, and will reinforce the ecological connection with Brompton Cemetery. Refer to DAS Chapter 7 (EC.PA.08). and associated sitewide strategies in the Design Code (EC.PA.C).
	b) Integrated water management A sustainable, integrated water management system should be devised to minimise water demand and waste water. Measures may include utilising grey water, using rainwater for irrigation, extensive use of sustainable drainage (SuDS) landscape features, infiltration.	The Integrated Water Management Strategy provides a framework to sustainably manage water supply, waste water and flood risk in an integrated way, and to provide guidance on how the required infrastructure should be planned, provided and managed. The Cascades water feature looks to use captured rainwater that is filtered and polished to a level suitable for use within the public realm. WSP have developed a sitewide strategy to capture and reuse rainwater for landscape irrigation. Refer to DAS Chapters 5, 6 and 7 (EC.PA.08) for more information.
	c) Trees that thrive Best practice should be applied to tree planting, including prioritising trees in the ground (as opposed to on a deck), soil quality, tree pit depth, irrigation systems and maintenance, and integrating water management and tree planting by planting trees in SuDS. Tree species should include a variety of disease and climate change resistant species, including trees of a substantial scale.	Significant new tree planting is proposed on both terra-firma and above structure. In both instances the Illustrative Masterplan has been coordinated to ensure suitable soil depth and structural loading capacity is provided (apart from where there are existing constraints such as Warwick apron and West Brompton apron). A large variety of tree species have been suggested to ensure climate resilience. The commitment is to: <ul style="list-style-type: none"> <li>• Re-open the Site through natural landscapes, with c. 6 hectares (c. 15 acres) of publicly accessible landscape, including the greened or treelined roads and crescents.</li> <li>• Deliver a network of interlinked Exhibition Gardens and spaces containing a diversity of planting strategies to create differing natural landscapes, enabling a wide variety of uses in the public realm.</li> <li>• Ensure the Site has a Biodiversity Net Gain of 85% which is &gt;75% over the Environment Act requirement of 10% (i.e. policy).</li> <li>• Plant a minimum of 1,000 new trees of which over 50% will be semi-mature.</li> <li>• Enhance the existing ecological corridor through the Site.</li> <li>• Prioritise climate-resilient and native species to create sustainable ecosystems.</li> </ul> Refer to DAS Chapters 7 (EC.PA.08) and the Design Codes (EC.PA.C) for more information.



# 10.3 RBKC Placemaking Framework Tracker



## Priority 1: Public realm first (continued)

Policy scope	Policy requirement	Scheme provision / response
	<p>d) Air quality positive</p> <p>The development should be air quality positive. This can be achieved, through a range of strategies that include prioritising the use of sustainable clean energy sources, implementing strategic architecture and design to avoid tunnelling effects created by buildings, appropriate planting close to sources of pollution and minimising emission sources from within the site.</p>	<p>The Proposed Development will deliver cleaner air across the Site. Ambitions include removing sources of pollution, working with partners to tackle emissions at source, and investigating new technologies to trap and remove pollutants from the atmosphere. Sitewide strategies have been established with the commitment to:</p> <ul style="list-style-type: none"> <li>• Not use combustion engines to drive the plant within the completed buildings or public realm other than for life safety (e.g. backup generators, which will use sustainable biofuels, until they can be replaced by electric back-up).</li> <li>• Contain above ground vehicle movements to perimeters of the Proposed Development, maximising car free public realm, safety for pedestrians and with a focus on electric vehicles (or equivalent) and limiting combustion vehicles.</li> <li>• Repurpose the existing Table and enclose the section of the West London Line on the east and west sides, limiting pollutant egress from cross Site rail traffic.</li> <li>• Provide electric charging points to all parking spaces to promote EV uptake.</li> <li>• Provide electric car club spaces for 25 vehicles (more than policy) promoting vehicle sharing for residents and the wider community.</li> </ul> <p>The Proposed Development maximises opportunities to utilise ecology to clean and improve air quality, buffering open spaces like Warwick Square and West Brompton Square from pollutant sources and optimising appropriate planting. Buildings across the masterplan have further been placed to minimise wind channelling and buffer open spaces from pollution sources like the A4.</p> <p>Refer to DAS Chapters 5, 6 and 7 (EC.PA.08) and the Environmental Statement (EC.PA.12) for more information.</p>



# 10.3 RBKC Placemaking Framework Tracker



## Priority 1: Public realm first (continued)

Policy scope	Policy requirement	Scheme provision / response
1.3 Open space for everyone	<p>a) Generous open space</p> <p>The scheme should incorporate open space of sufficient and varying scales to break up the built form and to allow for a range of people and activities outdoors including play, food growing, informal sports and fitness, dog walking, culture, events, wild or natural play, intergenerational mixing.</p>	<p>The network of open spaces across the masterplan are highly varied, offering opportunities for a range of activities and experiences. The Illustrative Masterplan contains c. 8.25 ha (20.38 acres) of publicly accessible open space within the planning application boundary, approximately 3.92 ha (9.68 acres) of which are within RBKC. The variety of open spaces across the masterplan include:</p> <ul style="list-style-type: none"> <li>• The Table Park, providing open lawn and multi-layered uses.</li> <li>• Warwick Square, a welcoming Flower Amphitheatre.</li> <li>• West Brompton Square, a generously landscaped local square that responds to the context of Brompton Cemetery.</li> <li>• The Bioline, a more naturalistic ecological zones.</li> <li>• The Cascades, creating a multi-level landscape incorporating water filtration ponds.</li> <li>• Aisgill Gardens, a community green integrating destination play space.</li> <li>• Lillie Sidings Square, a multi-functional space celebrating the Site's industrial heritage.</li> </ul> <p>The masterplan is underpinned by a Strategic Framework that delivers a well connected network of streets and open spaces catering for a variety of uses ranging from small and quiet to larger and more lively.</p> <p>Refer to the DAS Chapters 5, 6 and 7 (EC.PA.08). and the Design Code (EC.PA.C) for more information.</p>
	<p>b) Inclusive public realm</p> <p>The public realm should feel inclusive for all, taking particular account of children, teenagers, girls and women. Active measures including how the space is managed and activities to invite people in should be included.</p>	<p>The Public Realm Inclusivity Panel (PRIP) has been specifically set up by ECDC to ensure the public realm is developed to be inclusive. The panel has been running for 2 years and has helped to set the brief for areas of the landscape design, interrogated the masterplan and reviewed Control Documents such as Design Codes. The PRIP has been specifically selected to include a variety of genders, ages, physical needs and neurodivergence, ensuring a range of opinions and ideas have helped inform the Design Code and Illustrative Masterplan.</p>
	<p>c) Open space for the community</p> <p>The scheme should provide a variety of open space typologies, including unstructured informal spaces, local or neighbourhood spaces designed specifically for residents' needs such as local play, meeting people from the neighbourhood.</p>	<p>A series of recognisable open space typologies are provided including a park, squares, crescents, lanes and walks. Refer to Design Code and DAS Chapters 5, 6 and 7 for more information.</p>



# 10.3 RBKC Placemaking Framework Tracker



## Priority 2: Exemplar of environmental sustainability

Policy scope	Policy requirement	Scheme provision / response
2.1 vision for sustainability	“a) Exemplar of sustainability Sustainability should be dealt with in an exemplar way that goes above and beyond policy targets, and should be set out in a ‘sustainability charter’ that encompasses all aspects of the design and operation of the development.”	The Sustainability Strategy sets out commitments and aspirations demonstrating how the Proposed Earls Court Development will meet or exceed planning policy expectations and support delivery of a progressive sustainability agenda.  ECDC has set out a series of Principles for Future Living in a Sustainable Development Charter for the Earls Court Development. The charter does not form part of the planning application submission but contains an ambitious vision to deliver innovative buildings and spaces, enhance the environment, and produce economic and social benefits creating long term value for the local area.
	“b) Energy strategy An exemplar energy strategy should be developed for the site, to include consideration of how energy on the site could be modular and connect beyond the site.”	The Energy Strategy sets out ECDC’s ambition to go ‘Beyond Net Zero Carbon’ and by meeting or exceeding policy expectations and supporting delivery of a progressive energy solution for the Earls Court Development.  Refer to Energy Strategy (EC.PA.22) for more information.
	“c) Building design The masterplan should demonstrate how the future detailed design of buildings can deliver high environmental performance, as well as making the most of passive design measures.”	At the heart of the Sustainability Strategy is the construction of high-performing buildings designed following the principles of Passivhaus and considering progressive National Australian Building Environment Rating System – United Kingdom (NABERS UK) ratings, ensuring ultra-efficient, low-energy living and working spaces.
	“d) Housing design All homes should be designed to maximise environmental comfort whilst minimising the need to use energy for heating and cooling. Double aspect units are a priority.”	At a masterplan scale, Plot layouts have been carefully considered in response to microclimate analysis, ensuring buildings are able to receive good levels of daylight and sunlight and achieve good levels of comfort with regards to wind.  To minimise energy demands Detailed Components coming forward will be, where possible, designed using Passivhaus principles, aiming at high environmental performance.  The Strategic Framework and Control documents provide flexibility to optimise dual-aspect during the detailed design stages. The Detailed Components that form part of the Hybrid Application demonstrate the ratio of dual-aspect homes and residential quality that can come forward and provide a typology benchmark for the masterplan.  Refer to the DAS: Volume 2 RBKC Detailed Component (EC.RBKC.02) for more information.
2.2 Site-wide strategies for managing environmental impacts	"a) Contaminated land Any intrusive site investigation, risk assessment and land remediation should be approached in a site-specific way and follow the principles of sustainable remediation."	Previous investigations at the Site have identified localised areas of contamination. Further targeted ground investigations would be undertaken in advance of works commencing on-site and mitigated as necessary.



# 10.3 RBKC Placemaking Framework Tracker



## Priority 2: Exemplar of environmental sustainability (continued)

Policy scope	Policy requirement	Scheme provision / response
	<p>"b) Waste management A strategy for waste management should deal with waste on site and waste arising from the development by providing innovative facilities and efficient waste collection. The overall strategy should include construction waste, in line with best practice."</p>	<p>The construction Site Waste Management Plan sets out a strategy to assess the impacts of demolition and construction of the masterplan project. Waste targets during construction and the control of waste are set in accordance with the Environmental Protection Act Duty of Care and are outlined in the Construction Site Waste Management Plan (EC.PA.20).</p>



# 10.3 RBKC Placemaking Framework Tracker



## Priority 3: Part of the city

Policy scope	Policy requirement	Scheme provision / response
3.1 Completing Earl's Court	"a) Landscape character The scheme should respond to and incorporate the positive and distinctive aspects of the landscape character of Earl's Court, informed by an analysis of the area surrounding the site."	The landscape proposals draw from the local and wider context, referencing recognisable typologies such as parks, squares, crescents, lanes and walks. They are developed through an analysis of the local character and stitch the masterplan into the wider neighbourhood.  Refer to DAS Chapters 3,4,5 and 6 (EC.PA.08), and Design Code (EC.PA.C) for analysis of the local character and the strategic and illustrative design response.
	"b) Public realm The site layout and routes through should take in a sequence of streets and spaces characterised by urban greening, allowing for clear direct thoroughfares as well as meandering routes."	The Strategic Framework provides a carefully considered network of streets and open spaces that are laid out to accommodate generous landscaping and a clearly legible hierarchy of spaces. Within the framework, nature, as one of the four place pillars, will create the identity for Earls Court. It will consist of a network of Exhibition Gardens; a series of areas with changing character, connected through landscaped routes across the Site.  Refer to DAS (EC.PA.08), and Design Code (EC.PA.C) for more information.
	"c) Familiar streets The development should be a street-based, walkable neighbourhood. Streets should include sensitively integrated on-street parking for a proportion of the spaces for Blue Badge holders required for the development."	Earls Court Development will offer a pedestrian first public realm that prioritises people and connects the Site back into the local street network. The primary public open spaces are vehicle-free, with only emergency and out of hours servicing vehicles permitted access. This helps to create a safe environment and contributes to the sense of place and vibrancy of the public realm at the centre of the Site. Some routes permit vehicular movement to provide adequate access to buildings. Generous and safe space for pedestrian movement is ensured on all of these routes. Blue Badge parking spaces are provided and integrated with street trees/planting.  Refer to DAS (EC.PA.08), Design Code (EC.PA.C) and Parameter Plans (EC.PA.B).
	"d) Building heights The design of any building over 10 storeys should be of exceptional quality. They should be sustainable and innovative in their design and construction methods."	The approach to height across the masterplan has been carefully considered and iteratively developed through engagement with planning officers from both boroughs, the GLA, and Historic England, public engagement and townscape and heritage consultant input. This process informed the distribution of massing and location of taller buildings including responding to daylight/sunlight as well as wind analysis. Control Documents, including the Design Code have been iteratively developed through illustrative plot testing as well as parallel detailed design development of Detailed Components. It has informed a comprehensive number of design principles that are captured in the Design Code and establish how architectural quality within a coherent masterplan will be achieved. Further to the Design Code, the Detailed Components coming forward are for the tallest buildings on the site. The detail provided in the submission demonstrates exceptional quality, sustainability and innovation, and sets the benchmark for future RMAs.  Refer to the Design Code, DAS Chapters 3, 5 and 6 (EC.PA.08) and the Detailed Component DAS.

# 10.3 RBKC Placemaking Framework Tracker



## Priority 3: Part of the city (continued)

Policy scope	Policy requirement	Scheme provision / response
	"e) Rich architectural variety The scheme should demonstrate, through its design and approach to development, how the rich variety and high architectural quality of Earl's Court and the wider borough will be attained. The scheme should include a strategy for plot design that ensures that there is a variety of scales and range of architecture on the site."	A rich variety of building typologies is proposed for Earls Court. It draws from the analysis of existing local character to integrate new proposals with the wider neighbourhood. Extensive plot testing has been undertaken to demonstrate the approach and has been engaged on with officers throughout the design development of the Illustrative Masterplan and Control Documents.  Refer to the Design Code (EC.PA.C), Parameter Plans (EC.PA.B) and DAS Chapters 3, 5 and 6 (EC.PA.08) for the approach taken in the Proposed Development and Illustrative Masterplan. Refer to DAS: Volume 2 RBKC Detailed Component (EC.RBKC.02) for additional detail on how building designs will embed a contextual architectural response.
	"f) Design codes Design codes with specific, detailed parameters should be produced and submitted as part of a planning application. These should provide guidance for the design of buildings, the spaces in between them, and the landscape."	The Earls Court Design Code and Parameter Plans have been developed through engagement with planning officers. They provide a comprehensive set of design principles and guidance for the sitewide strategies as well as the design of buildings, public realm and landscape. Design Codes have been tested and informed by the Illustrative Masterplan and Plot testing, as well the design of Detailed Components.  Refer to the Design Code (EC.PA.C), Parameter Plans (EC.PA.B), DAS Chapter 6 (EC.PA.08) and DAS: Volume 2 RBKC Detailed Component (EC.RBKC.02) for more information.
3.2 Convenient and appealing connections	"a) Routes to key destinations Routes to and from the site to key destinations should be convenient and attractive for walking and cycling and connect into the existing public transport and cycleway networks. Pedestrian crossings at the site's key interfaces should be improved."	Key routes, particularly to and from the transport networks are designed to be legible and inviting. Examples include: Warwick Square addressing Earl's Court station and West Brompton Square addressing West Brompton station with pedestrian crossings, making these routes convenient, attractive and safe to use.  Refer to Design Code and DAS Chapters 5, 6 and 7 (EC.PA.08) for more information.
	"b) East-west route through the site There should be a clear and visible east-west route that is appealing for people to walk and cycle from the west of the Opportunity Area to Earl's Court Road District Centre via Earl's Court station."	A clearly defined east-west route for pedestrians and cyclists has been established within the Strategic Framework and Control Documents, and is tested in the Illustrative Masterplan. The route is anchored by Warwick Square in the east and Aisgill Gardens in the west. The route runs through the Table Park and Cascades, which have been designed to provide accessible routes, lift access as well as stepped routes, allowing all users to easily navigate the space. The route is defined within Design Code (EC.PA.C) and Parameter Plans (EC.PA.B).
	"c) Connections north The development should facilitate cycle and pedestrian connections to the north over the A4, including access from the west of the West London Line. A two-way cycle route on Warwick Road and improvements to a crossing over the A4 should be explored."	The masterplan establishes a clear north-south route within the Strategic Framework and Control Documents, responding to desire lines between Lillie Road, Warwick Road and West Kensington station. Beyond the Planning Application boundary, works to improving cycle infrastructure along Warwick Road by creating a new dedicated cycle lane and improvements to the crossing outside Earl's Court station have been explored. Opportunities to improve pedestrian connections from Cluny Mews to St Cuthbert's Lane have been explored and enabled, and are subject to third party agreement.  Refer to DAS Chapters 5, 6 and 7 (EC.PA.08) for more information.



# 10.3 RBKC Placemaking Framework Tracker



## Priority 3: Part of the city (continued)

Policy scope	Policy requirement	Scheme provision / response
	"d) Vehicle movements and servicing The layout of the scheme should allow for necessary deliveries and other servicing while designing out the possibility of cut-throughs for motorised vehicles. Traffic movements should not be managed through excessive street clutter and signage. All non-residential servicing should be carried out underground using the northern access route."	Vehicular movement has been carefully integrated into the Proposed Development to create a car-free public realm throughout a large part of the masterplan. Vehicles are integrated within the design of streets where appropriate, providing for access, parking, drop-off and servicing. Controlled access points are proposed in selected locations to limit vehicular movement at the centre of the Site to servicing and emergency vehicles. Servicing to Plots in the centre of the Site is enabled through the undercroft formed below the Table Park, which is accessed via St Cuthbert's Lane.  Refer to the Design Code (EC.PA.C), Parameter Plans and DAS Chapter 7 (EC.PA.08) for more information.
3.3 Sensitive integration	"a) Warwick Road threshold A reimagined London square should be created at the Warwick Road apron, providing a green space that is a point of relief from the busy road. Buildings with active frontages and a civic or cultural function, at least at ground floor, should frame the space. A street running along the side of the space should be used to provide a vehicular connection from Warwick Road, maximising connectivity. This space should be provided as part of the first phase of the development."	Warwick Square is reimagined as a London Square informed by careful analysis of the local and wider London context. It provides a clearly defined threshold along Warwick Road and is framed by trees on all edges addressing streets or lanes. The former Exhibition Centres steps are reinterpreted as a Flower Amphitheatre to provide a space for sitting and dwelling, and the opportunity to host cultural or other public events. The space is framed by buildings all of which have active frontages that could accommodate a mix of uses. Lanes run along the side of the space to provide vehicular and cycle connections from Warwick Road. The space is part of the first phase.  Refer to Design Code (EC.PA.C) and DAS Chapter 6, 7 and 9 (EC.PA.08) for more information.
	"b) Old Brompton Road threshold The site's interface with Old Brompton Road should reflect and continue the character of the immediate neighbourhood with fine-grain active uses at ground floor and incorporate tree planting."	The Proposed Development stitches into the existing context of Lillie Road and Old Brompton Road by establishing a clearly defined local square outside of West Brompton station that is framed by buildings and fine grain active frontages. West Brompton Square is generously landscaped responding to the Brompton Cemetery setting and enhances the ecological corridor along the West London Railway Line. Extensive public realm improvements along this edge to widen the pedestrian routes along Lillie Bridge and improve the crossing to West Brompton station have been explored.



# 10.3 RBKC Placemaking Framework Tracker



## Priority 3: Part of the city (continued)

Policy scope	Policy requirement	Scheme provision / response
	<p>"c) Response to conservation areas The scheme should show a clear response to the relationship with the neighbouring conservation areas, taking into account buildings, landscape features and spaces between buildings, the garden squares, gaps between buildings. Back-to-back development should be pursued to the rear of the crescents that line the boundary of the site in Philbeach Conservation Area."</p>	<p>The masterplan has been designed in response to an in-depth analysis of the local area, including the existing townscape, urban structure, architectural character, conservation areas and listed buildings which neighbour the Site. Strategies to respond to the historic context have been developed alongside townscape and heritage consultant input and through engagement with planning officers in both boroughs, the GLA and Historic England.</p> <p>Massing and building heights have been carefully considered and distributed to respond to the Site context. Building heights step up from the sensitive edges by extending the neighbouring building scale and transitioning to medium heights further into the Site, where taller buildings frame the Table Park. The Proposed Development has evolved based on a detailed understanding of townscape, heritage and visual impact in long-range, midrange and immediate views, including taking account of any cumulative impact. Guidance is provided in the Design Code responding to key townscape and heritage views to ensure these are given special consideration from key areas within the conservation area. These will provide more specific guidance for future Applications for Reserved Matters Approval (RMAs) for the Outline Components.</p> <p>Attention has been given to enhancing the setting to the west of St Cuthbert's Church, and maintaining visual clarity in views of the church from Philbeach Gardens. Back-to-back development has also been proposed along Eardley Crescent, in the form of townhouses, where below ground infrastructure considerations enable that to occur. The rear of Philbeach Gardens has been sensitively addressed by setting buildings away from the boundary and stepping down in scale to respond to the existing terraced houses. A landscaped lane creates a buffer to adjacent properties and responds to requirements driven by below ground infrastructure constraints.</p> <p>Refer to the Design Code (EC.PA.C), Parameter Plans (EC.PA.B) and DAS Chapters 3, 5 and 6 (EC.PA.08) for the approach taken in the Proposed Development and Illustrative Masterplan. Refer to DAS: Volume 2 RBKC Detailed Component (EC.RBKC.02) for additional detail on how building designs are embedding a contextual architectural response.</p>
	<p>"d) St Cuthbert's Church The scheme should create a public space, including playspace, to the rear (west) of St Cuthbert's Church, sensitively designed to enhance the setting of the Grade I building, and provide a connection to Philbeach Gardens and Cluny Mews."</p>	<p>The setting of St Cuthbert's Church is enhanced through a sensitively designed public realm and carefully composed massing and height along St Cuthbert's Lane. Existing trees along the boundary are retained and added to, enhancing the setting of the church as seen from the west while proposed buildings have been positioned and shaped in response to townscape and heritage analysis. A connection through to Cluny Mews has been explored and enabled. Due to access constraints this can't be accommodated within the Site boundary, but could be delivered on neighbouring land, subject to a third party agreement.</p> <p>Refer to Design Code (EC.PA.C) and DAS Chapters 6 and 7 (EC.PA.08) for more information.</p>



# 10.3 RBKC Placemaking Framework Tracker



## Priority 3: Part of the city (continued)

Policy scope	Policy requirement	Scheme provision / response
	<p>"e) Brompton Cemetery The scheme should be designed with extensive outdoor space for a variety of recreational activities including informal play, sports and dog walking."</p>	<p>The masterplan provides significant new open space for a variety of recreational activities. The public realm is composed of a variety of spaces that cater for range of different uses. These include a variety of green spaces and squares that offer formal and informal play space, hard event space, as well as a network of pedestrian priority routes for walking. The public realm and landscape is designed to complement the existing offering at Brompton Cemetery and add to play and leisure space for new and existing communities around the Site.</p> <p>An enhanced connection to Brompton Cemetery is established through the landscape response at West Brompton Square and the Bioline (subject to third party agreement). It extends the landscape character, ecology and walking route of the cemetery into the site and up onto the Table Park.</p>



# 10.3 RBKC Placemaking Framework Tracker



## Priority 4: Varied and rich urban life

Policy scope	Policy requirement	Scheme provision / response
4.1 A place for people to settle	"a) A choice of homes A range of home typologies, as well as a range of sizes, should be provided within each cluster of homes."	A diverse mix of housing typologies is proposed across the masterplan, creating a diverse new neighbourhood catering for people of all ages and backgrounds. This ranges from purpose-built student accommodation (PBSA), later-living, family homes, affordable housing, BTS and BTR provision. Within individual buildings, a mixed tenure is proposed to secure an appropriate range of sizes and home types.  Refer to the Design Code (EC.PA.C), Development Specification (EC.PA.A), DAS Chapters 5 and 6 (EC.PA.08), and DAS: Volume 2 RBKC Detailed Component (EC.RBKC.02) for more information.
	"b) Adaptable homes Homes should be designed to be adaptable so that the same property can be used by the same household at different life stages and by different types of households, such as sharers and families. Internal layouts should be designed so that rooms can accommodate different furniture arrangements."	The Detailed Component and future RMAs will meet policy requirements to ensure adaptability. Refer to DAS: Volume 2 RBKC Detailed Component (EC.RBKC.02) for more information.
	"c) Acoustic design Noise and vibration should be considered at the initial design stage, including building location, layout and insulation, as should measures to reduce noise at source or transmission path where possible."	Acoustics have been considered from early masterplan design stages, informing the location, design and use of proposed Plots to ensure the impact of existing noise on the Site is mitigated. This has contributed to the placement of commercial buildings along West Cromwell Road, Warwick and West Brompton Squares. Acoustic design principles for individual buildings have been outlined in the Design Code and are considered in further detail within the Detailed Component.  Refer to DAS Chapters 4, 5 and 6 (EC.PA.08), the Design Code (EC.PA.C) and DAS: Volume 2 RBKC Detailed Component (EC.RBKC.02) for more information.
	"d) Community housing The mix, distribution, quantum and phasing of community housing tenures should be planned so that it can contribute to establishing a community that is balanced and mixed. Strategies should also be put in place to provide spaces which promote the integration of new and existing communities. The scheme should follow the principles established in the Community Housing SPD."	Community Housing will be provided in a tenure blind basis. The quantum and tenure will continue to be discussed during the determination period. Community Housing will have regard to the Community Housing SPD.





# 10.3 RBKC Placemaking Framework Tracker



## Priority 4: Varied and rich urban life (continued)

Policy scope	Policy requirement	Scheme provision / response
	"e) Benefits of sustainability for residents The scheme should set out how the design of homes and their energy use delivers significant benefits for residents as compared with living in another new development or in older housing stock. This should include energy costs, comfort of the internal environment especially in extreme weather, and accessibility of data to inform choices."	The Energy Strategy sets out how incorporation of passive design strategies into building architecture and layout, will reduce reliance on active heating, cooling, and lighting systems, thus minimising energy consumption and operational costs for future residents.  Refer to the Energy Strategy (EC.PA.22) for more information.
	"f) Personalising space Homes and the spaces around them, including balconies, thresholds and communal gardens, should be designed to allow space and flexibility for personalisation, for example with seating, food and plant growing."	The public realm across the Proposed Development is designed to be welcoming and inclusive, allowing residents agency to play and take part in communal activities. Homes across the masterplan also have access to outdoor communal and private amenity spaces. Additionally, where possible homes have their own front door on the street with defensible space. Detailed design of homes is demonstrated in the Detailed Component DAS.  Refer to DAS Chapter 6 (EC.PA.08) and the DAS: Volume 2 RBKC Detailed Component (EC.RBKC.02).
	"g) Community facilities Community facilities should be located, designed and managed in a way that fosters community activity and meeting. This could include collocation of uses, organised events, or an appealing adjacent public space in which to linger. Opportunities to include community facilities within other buildings or make them available for community use should be explored."	The masterplan includes inherent flexibility to provide multiple opportunities for community spaces within buildings and the public realm. An early years education facility is applied for in detail and will sit at the base of ECO6.  Refer to DAS: Volume 2 RBKC Detailed Component (EC.RBKC.02) for more information.
4.2 The value of active uses	"a) Active uses and phasing Active ground floor uses should be included at each phase of the development, along with a strategy for their occupation, to include meanwhile uses where necessary."	Key spaces and routes in each phase of the masterplan have been designed to be lined with active ground floor uses. The primary east-west route and Table Park is included within Phase 1, ensuring strategic connections and public space with active ground floor uses is delivered from the beginning. A Temporary Use Strategy (EC.PA.49) sets out the approach to temporary use, including commitments delivered to date as well as the strategy for temporary uses during construction.  Refer to DAS Chapter 8 (EC.PA.08), and Design Code SW.B.24 / 25 (EC.PA.C) for more information.



# 10.3 RBKC Placemaking Framework Tracker



## Priority 4: Varied and rich urban life (continued)

Policy scope	Policy requirement	Scheme provision / response
	"b) Ground floor activity A plan of the ground floor of each phase of development should be produced to demonstrate how it will be varied, vibrant and active at different times of the day and year. It should show the scale and footprint of commercial units, public access, the types of activities, the relationship between activity in the buildings and the spaces outside."	Key routes and open spaces across the masterplan have been designed to create legible, active streets, lined with active ground floor uses. The Illustrative Masterplan and plot testing demonstrate a variety and flexibility in use and how these inform and respond to different Character Areas, all of which has been captured in the Design Code. Detailed Components provide specific information on ground floor layouts and uses that activate the buildings and public realm.  Refer to the Design Code (EC.PA.C), DAS Chapters 5, 6 and 7 (EC.PA.08) and DAS: Volume 2 RBKC Detailed Component (EC.RBKC.02) for additional detail. For phasing refer to the Indicative Phasing Strategy (EC.PA.48) and DAS Chapter 8 (EC.PA.08).
	"c) Commercial strategy The ground floor of office and other commercial buildings should contribute interest and activity to the public realm; opportunities for wider public access should be explored."	Commercial buildings across the masterplan are designed to contribute to the surrounding public realm and provide active uses unique to their location. At Warwick Square commercial buildings frame the space and provide active frontages and uses that will include publicly accessible spaces. The commercial cluster located around Empress Place equally activates the public realm and includes one of the cultural hubs on the Site that will be accessible from the Table Park. Principles to ensure visual openness and engagement with workspace frontages are outlined in the Design Code, and tested in the Illustrative Masterplan and Plot testing that has informed the Control Documents.
	"d) Affordable workspace The affordable workspace on the site should be designed to meet the needs of local people, local organisations and to complement the wider commercial and cultural strategy for the site."	Refer to the Affordable Workspace Strategy (EC.PA.28) for information.
	"e) Inclusive The scheme should identify measures, through its design and management, that will ensure the development is inclusive and feels welcoming to and comfortable for all. Measures may include programming of events, familiar urban typologies such as streets, and indoor or covered public space."	The Proposed Development has been refined continuously alongside engagement with specialist inclusive design consultants, borough-led Inclusive Design Review Panels and wide-reaching public engagement to ensure the development is inclusive and feels welcoming and comfortable for all. This included establishing the Public Realm Inclusivity Panel (PRIP), a group made up of local people of varying backgrounds, ages and needs. Engagement with the PRIP occurred on a regular basis and informed the public realm, landscape and approach to building design, which has been captured in the Design Code.  Refer to DAS Chapter 4, 7 (EC.PA.08), the Design Code (EC.PA.C) and the Statement of Community Involvement (EC.PA.33) for more information.

# 10.3 RBKC Placemaking Framework Tracker



## Priority 4: Varied and rich urban life (continued)

Policy scope	Policy requirement	Scheme provision / response
	"f) Supporting Earl's Court Road The scheme should include a range of measures designed to have a positive impact on Earl's Court Road District Centre, derived from identified opportunities and threats to the centre. Such measures should include improving physical connections between the site and the centre and curating meanwhile activity in vacant units on Earl's Court Road."	The Retail Strategy sets out ECDC's aspirations for retail and other town centre uses at Earls Court. The strategy seeks to compliment not compete with Earl's Court Road. The Retail Impact Assessment concludes that the Earls Court Development will result in additional expenditure on Earl's Court Road.
4.3 Putting Earl's Court back on London's cultural map	"a) Cultural use criteria A new cultural facility should meet the following criteria: 1. Be high quality, bringing great work to Earl's Court 2. Attract audiences from beyond the local area 3. Be distinctive, belonging in Earl's Court 4. Have strong links with local businesses and local people 5. Be welcoming for everyone, make people feel at home in its spaces 6. Have programming that interests a wide range of people – opportunities that people might stumble across as well as ticketed events 7. Provide spaces for people to develop new creative work – not just show work that has been developed elsewhere."	The Cultural Strategy for the Site has been prepared by The Earls Court Development Company (ECDC) in partnership with Sound Diplomacy, working closely with the masterplan architects, Hawkins\Brown and Studio Egret West. Culture plays a defining role within the masterplan, designed into buildings and across the public realm. ECDC have committed to four cultural hubs across the masterplan: <ul style="list-style-type: none"> <li>• West Brompton Crescent</li> <li>• Empress Place</li> <li>• Exhibition Gardens</li> <li>• Lillie Sidings</li> </ul> Refer to the Cultural Strategy (EC.PA.31) for more information.
	"b) Flexibility for a principal cultural use The masterplan should have built in flexibility to accommodate different types of 'anchor tenant' within the layout."	The three proposed cultural venues are different in character, size and location, and Plot testing has illustrated how these are able to accommodate different types of tenants, contributing to a wider network of diverse active uses on the Site. The Parameter Plans and Development Specification ensure controlled flexibility for individual buildings and Plots is inherent in the Proposed Development. Refer to the Design Code (EC.PA.C) and the Development Specification (EC.PA.A) for more information.
	"c) A creative ecosystem An evolving, wide-ranging strategy for culture and placemaking should facilitate and encourage creative activity across the site, so that the scheme offers much more than a singular or traditional cultural infrastructure."	Cultural spaces have been designed as part of a network of smaller and larger venues, with food & beverage, retail and commercial spaces offering complimentary uses. This approach extends into the masterplan's wider landscape, art and lighting strategy to bring cultural uses into the public realm and to celebrate the Site's cultural heritage. Refer to the Design Code (EC.PA.C) and Chapters 5, 6 and 7 within the DAS (EC.PA.08) for more information.

# 10.3 RBKC Placemaking Framework Tracker



## Priority 4: Varied and rich urban life (continued)

Policy scope	Policy requirement	Scheme provision / response
	"d) Night-time economy Venues and activities connected with the night-time and evening economy should make up a significant element of the cultural strategy, designed in to the scheme at masterplan stage, and managed to create a safe and welcoming environment for all and minimise residential disturbance."	Active uses are envisaged to continue into the evenings, creating vibrant streets supporting Earls Court's night-time economy. Active evening uses are concentrated in or along busier public realm spaces such as the Table Park, Empress Place Boulevard, Lillie Sidings Square, West Brompton Crescent as well as Warwick Square and West Brompton Square. The masterplan has been designed alongside specialist lighting and security consultants to ensure spaces feel safe and welcoming throughout the night with appropriate light levels to minimise residential disturbance.  Refer to the Design Code (EC.PA.C), and Chapters 6 and 7 within the DAS (EC.PA.08) for more information.
	"e) Culture in the public realm The scheme should include a culture and public realm strategy to accommodate and foster cultural activity in appropriate locations within the public realm."	The Cultural Strategy establishes an approach to sitewide programming throughout the public realm, allowing for daily activation, seasonal events, performances, artwork and installations. The approach is embedded in the landscape, art and lighting strategies.  Refer to Chapters 5, 6 and 7 within the DAS (EC.PA.08) and Cultural Strategy (EC.PA.31) for more information.
	"f) Artists shaping the place Artists should be involved in creating permanent, programmed or temporary works of art, allowing for public participation through making and/or experiencing."	The art strategy outlines the approach to facilitate the creation of a wide range of artworks across the masterplan. This has already begun, with the creation of Empress Studios at Empress Place and a number of supporting temporary uses.  Refer to Chapter 7 within the DAS (EC.PA.08) for the approach to the sitewide art strategy, the Temporary Use Strategy (EC.PA.49) and Chapters 1 and 2 within the DAS (EC.PA.08) for information on temporary use commitments that have already been delivered.
	"g) Public art strategy A public art strategy shall set out how public art will influence each phase of the development including at masterplanning stage, in landscape design, and via meanwhile projects."	A dynamic and evolving sitewide art strategy will form an important part of ensuring Earls Court Development is a cultural destination within London. It sets out a framework for how to work collaboratively to create art that will reinforce a sense of place and tell the story of this unique part of London and its communities. A Temporary Use Strategy sets out the approach to temporary use, including commitments delivered to date as well as the strategy for temporary uses during construction.  Refer to Chapter 7 within the DAS (EC.PA.08) the Temporary Use Strategy (EC.PA.49).



# 10.4 Image Credits

Every effort has been made to trace the copyright holders, but if any have been inadvertently overlooked, the necessary arrangements will be made at the first opportunity.

Where images are not credited, they are owned by ECDC, the Team or unlicensed.

## Chapter 1: Introduction

No image credits.

## Chapter 2: A Vision for Earls Court

- p.23 Alamy Stock Photo (multiple)
- p.26 The Architects' Journal  
Alamy Stock Photo (multiple)  
SLA / Mikkel Eye

## Chapter 3: Site Context and Analysis

- p.39 The Architects' Journal
- p.40 National Library of Scotland  
Barton, N., Lost Rivers Of London
- p.41 National Library of Scotland  
Britain from Above, Historic England
- p.42 Britain from Above, Historic England
- p.44 Alamy Stock Photo (multiple)
- p.46 Alamy Stock Photo (multiple)
- p.47 Alamy Stock Photo  
Google Streetview (multiple)
- p.48 Keltbray
- p.51 Alamy Stock Photo (multiple)
- p.53 Pell Frischmann  
John McAslan + Partners  
Lodha UK
- p.54 Alamy Stock Photo (multiple)
- p.55 Alamy Stock Photo (multiple)
- p.56 Alamy Stock Photo (multiple)
- p.59 Alamy Stock Photo (multiple)
- p.65 Alamy Stock Photo (multiple)  
John McAslan + Partners
- p.66 Alamy Stock Photo
- p.76 Alamy Stock Photo

## Chapter 4: Design Evolution & Engagement

- p.123 Alamy Stock Photo (multiple)

## Chapter 5: The Strategic Framework

- p.157 Alamy Stock Photo
- p.158 Alamy Stock Photo
- p.168 Alamy Stock Photo (multiple)  
Hawkins\Brown (multiple)  
Maccreeanor Lavington / Tim Crocker  
Maccreeanor Lavington / John Sturrock

## Chapter 6: The Illustrative Masterplan

- p.185 Alamy Stock Photo (multiple)  
Howarth Tompkins / Philip Vile
- p.189 Maccreeanor Lavington / Tim Crocker
- p.193 SLA / Laura Stamer  
Studio Egret West
- p.199 Alamy Stock Photo (multiple)
- p.201 Alamy Stock Photo (multiple)  
Maccreeanor Lavington / Tim Crocker
- p.212 Studio Egret West
- p.216 SLA / Øystein Haara  
Maccreeanor Lavington / David Grandorge  
Hawkins\Brown
- p.218 Maccreeanor Lavington / Tim Crocker  
Alamy Stock Photo (multiple)
- p.220 Alamy Stock Photo (multiple)
- p.232 Alamy Stock Photo
- p.234 Alamy Stock Photo (multiple)  
SLA / Laura Stamer  
SLA

- p.236 Alamy Stock Photo (multiple)
- p.237 Alamy Stock Photo (multiple)  
SLA / Rasmus Hjortshøj
- p.240 SLA / Jens Lindhe  
SLA
- p.244 Alamy Stock Photo (multiple)
- p.253 Alamy Stock Photo
- p.256 Hawkins\Brown
- p.260 SLA / Rasmus Hjortshøj
- p.269 Alamy Stock Photo
- p.270 Alamy Stock Photo
- p.274 Alamy Stock Photo
- p.276 SLA / Mikkel Eye  
Alamy Stock Photo (multiple)
- p.278 SLA / Jens Lindhe  
Alamy Stock Photo
- p.280 Alamy Stock Photo  
Maccreeanor Lavington / Tim Crocker
- p.290 Studio Egret West  
Alamy Stock Photo (multiple)
- p.293 Alamy Stock Photo (multiple)
- p.295 SLA / Mikkel Eye
- p.296 Alamy Stock Photo  
SLA / Rasmus Hjortshøj  
SLA / Mikkel Eye

## Chapter 7: Spatial Strategies

- p.319 Alamy Stock Photo  
Studio Egret West  
SLA / Mikkel Eye  
SLA / Laura Stamer (multiple)  
SLA / Sigrid Bjorbeekmo
- p.320 SLA / Rasmus Hjortshøj  
SLA / Mikkel Eye (multiple)  
SLA / Torben Petersen  
SLA (multiple)



# 10.4 Image Credits

Every effort has been made to trace the copyright holders, but if any have been inadvertently overlooked, the necessary arrangements will be made at the first opportunity.

Where images are not credited, they are owned by ECDC, the Team or unlicensed.

- p.321 SLA / Mikkel Eye  
SLA / Jon Bjarni Hartarson  
SLA / Sigrid Bjorbekkmo (multiple)  
SLA / Laura Stamer
- p.322 SLA  
SLA / Mikkel Eye (multiple)  
SLA / Rasmus Hjortshøj  
SLA / Øystein Haara  
SLA/Jon Bjarni Hartarson
- p.326 SLA / Mikkel Eye (multiple)  
SLA / Tina Stephansen
- p.336 SLA (multiple)  
Studio Egret West  
SLA / Mikkel Eye (multiple)  
SLA / Rasmus Hjortshøj  
SLA / Øystein Haara  
SLA/Jon Bjarni Hjartarson
- p.339 SLA / Øystein Haara  
SLA / Mikkel Eye (multiple)
- p.340 SLA / Øystein Haara (multiple)  
SLA
- p.344 Alamy Stock Photo (multiple)
- p.346 Alamy Stock Photo (multiple)
- p.347 SLA / Jens Lindhe
- p.348 Studio Egret West
- p.351 Alamy Stock Photo
- p.353 Alamy Stock Photo (multiple)  
SLA / Øystein Haara  
SLA / Mikkel Eye  
SLA
- p.354 Alamy Stock Photo
- p.356 Alamy Stock Photo
- p.357 SLA / Mikkel Eye  
Alamy Stock Photo (multiple)
- p.358 Hawkins\Brown (multiple)

## Chapter 8: Phasing and Delivery

No image credits.

## Chapter 9: Conclusion

- p.393 Alamy Stock Photo (multiple)  
Keltbray

## Chapter 10: Appendices

- p.397 Alamy Stock Photo (multiple)
- p.398 Alamy Stock Photo
- p.399 Alamy Stock Photo (multiple)
- p.400 Alamy Stock Photo (multiple)  
John McAslan + Partners
- p.401 Alamy Stock Photo (multiple)
- p.402 Alamy Stock Photo (multiple)
- p.404 Alamy Stock Photo (multiple)  
John McAslan + Partners
- p.405 Alamy Stock Photo (multiple)



Thank you

Hawkins\Brown  
&  
Studio Egret West  
EC.PA.08  
July 2024

**The  
Earls Court  
Development  
Company**