

REVISED DRAWINGS

Please Index As

File Number

TP/99/0733

Jan. Feb. Mch. Apl. May June Jul Aug Sept Oct **Nov** Dec

Part 1

Part 11

Part 2

Part 12

Part 3

Part 13

Part 4

Part 14

Part 5

Part 15

Part 6

Part 16

Part 7

Part 17

Part 8

Part 18

Part 9

Part 19

Part 10

Part 20

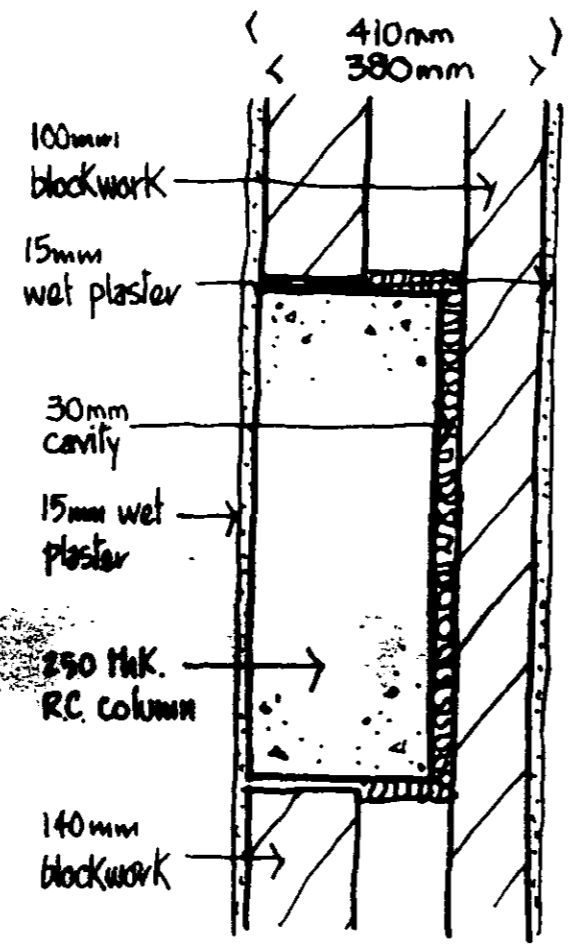

PLAN PARTY WALL - UPPER FLOORS

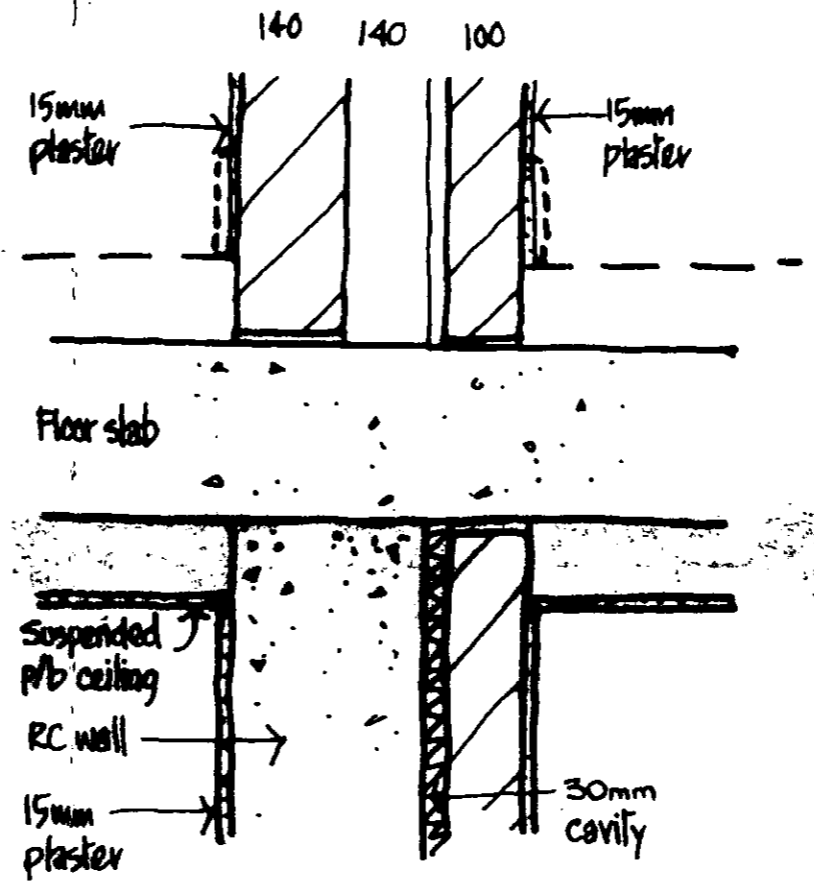

SECTION L/G - U/G FLOORS

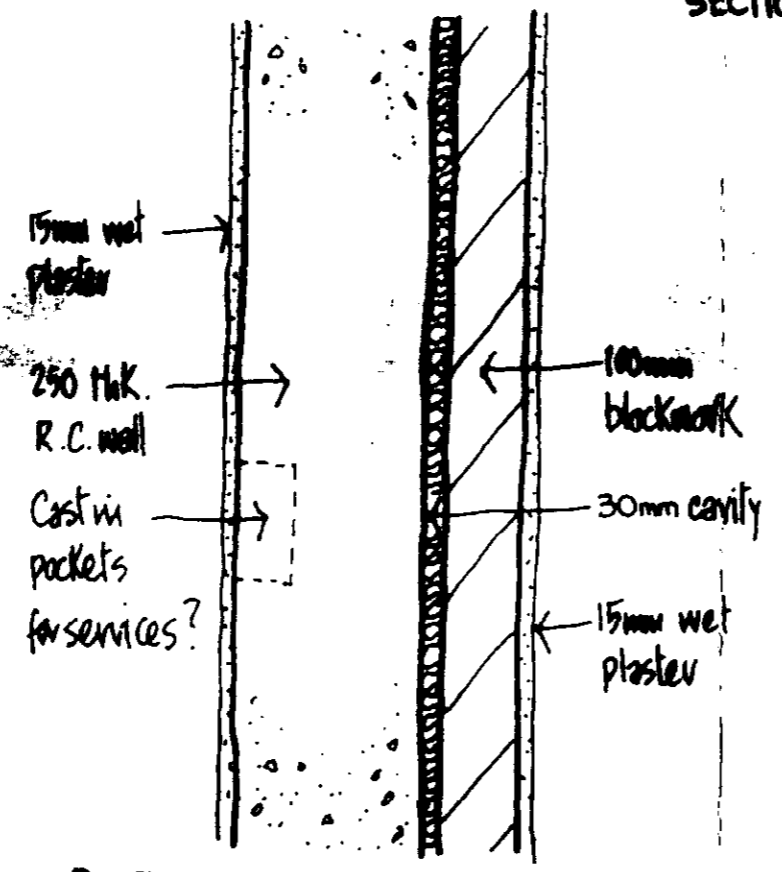

PARTY WALLS - PLAN LG FLOOR

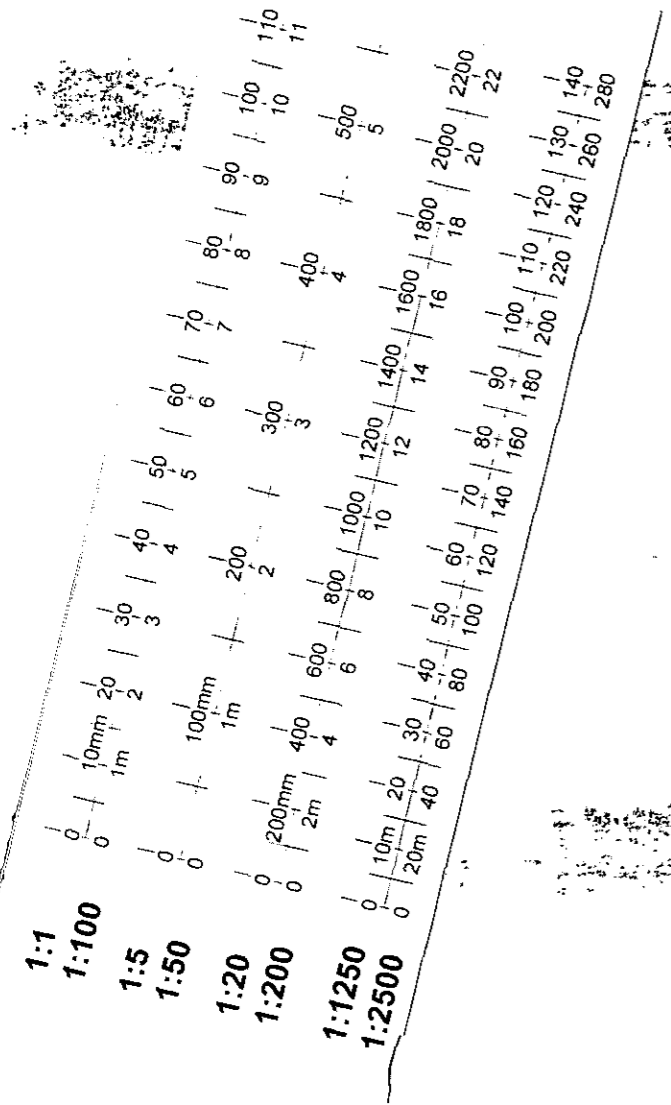

Note: all blockwork to party walls to be 1990 Kg/m³

In swimming pool areas walls to receive render in lieu of plaster finish

Received 23 AUG 2001 R.B.KAC
 Planning: Allocation

Broadway Mahan
 Architects & Designers
 10, Jalan Mahan, Subang Jaya
 47500 Subang Jaya, Selangor
 T: 03-552 0500
 F: 03-552 0505
 E: Way@broadwaymahan.com

Client: St James Homes
 Project: Campden Hill
 Description: West Terrace Houses
 Party Wall Construction

Status: Preliminary
 Scale: 1:10
 Date: 08-99
 Job #: 8130
 Drawing #: SK09
 Revision: AB

Original size 50mm © Broadway Mahan Ltd

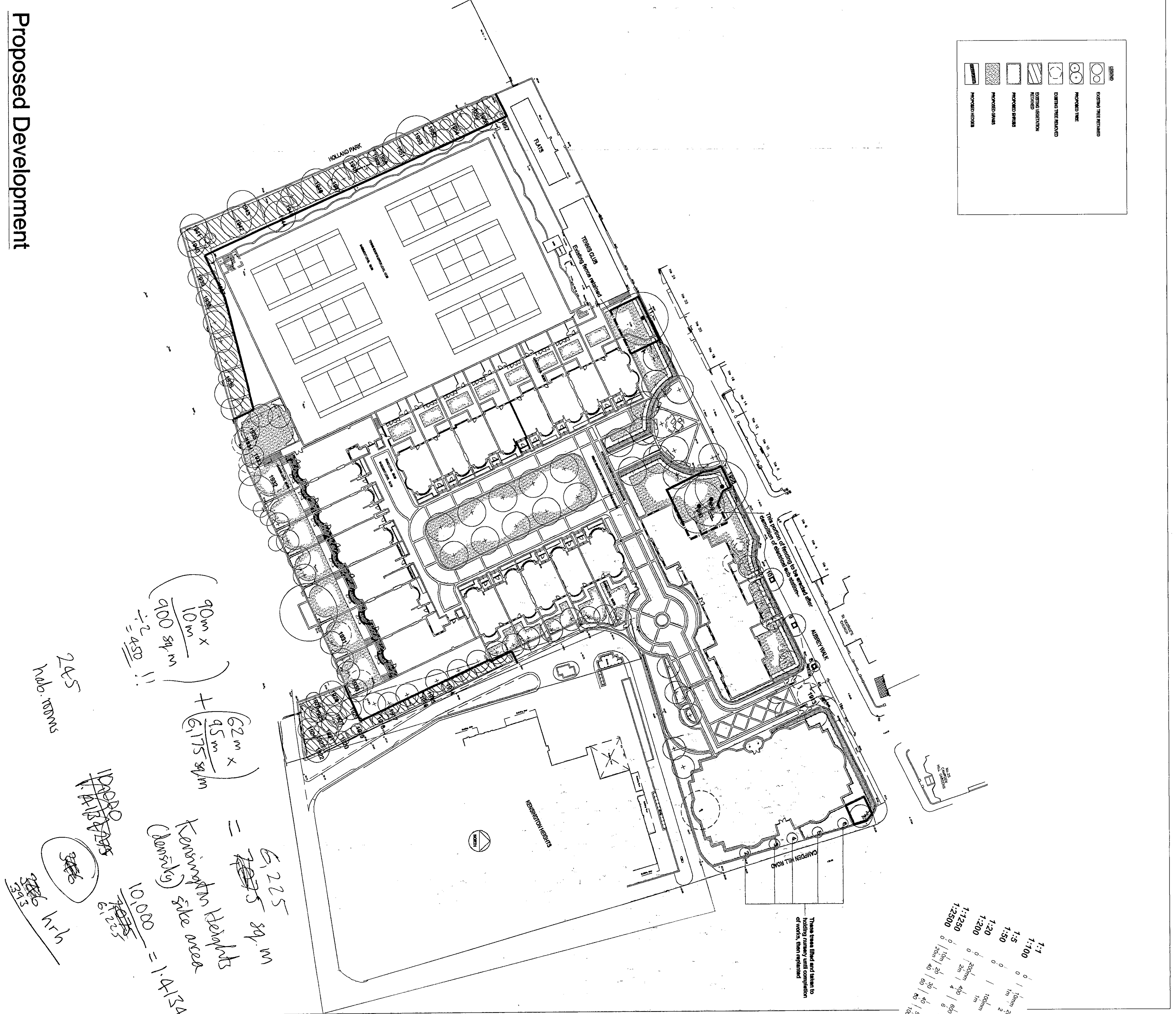
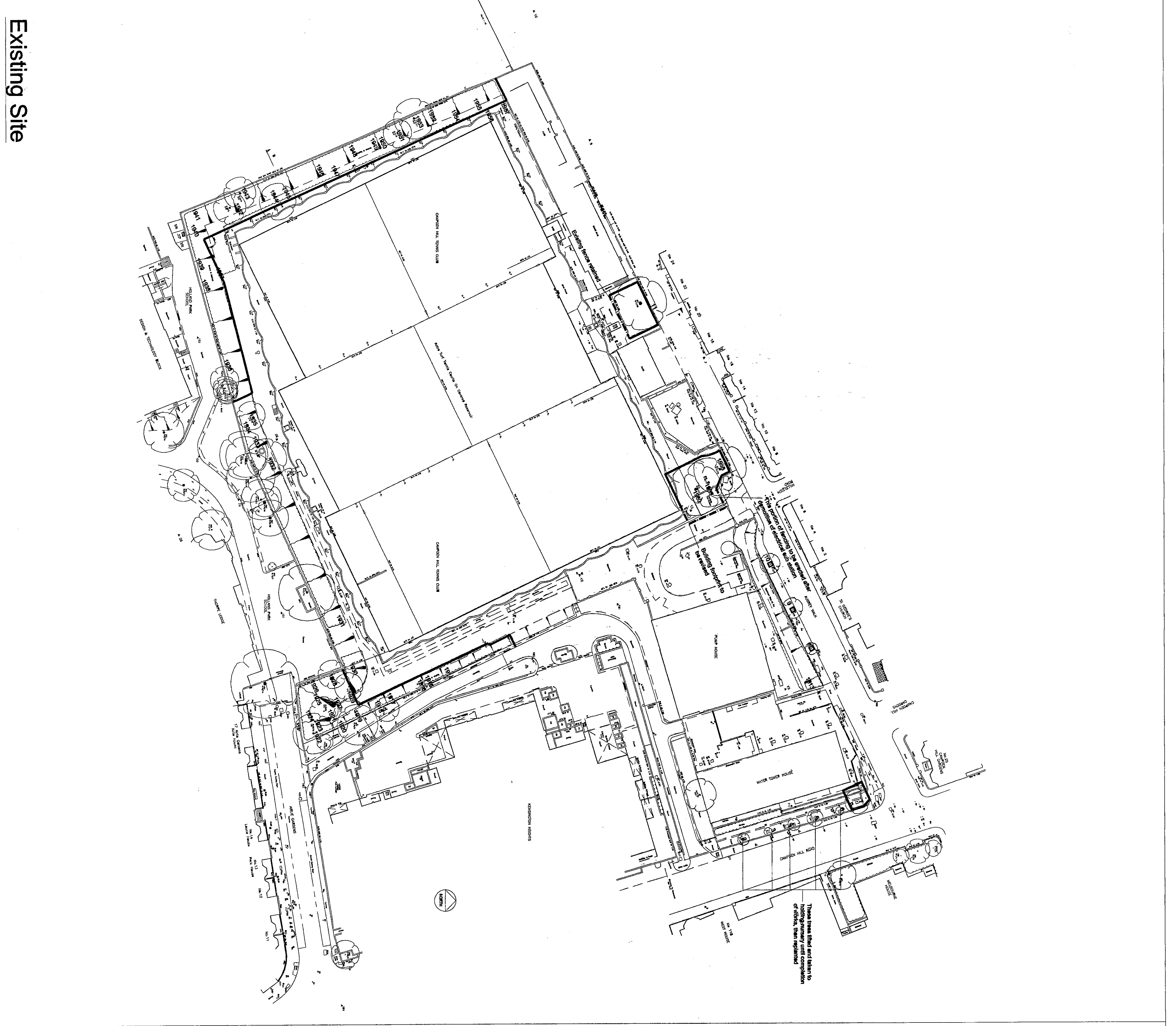

CONTRACTORS ARE NOT TO SCALE DIMENSIONS FROM THIS DRAWING

LEGEND

PROTECTION AREAS IN ACCORDANCE WITH SPECIFICATIONS

R&K & C
TOWN PLANNING
12 FEB 1999
RECEIVED

AUBREY WALK
CAMDEN HILL RESERVOIR

BROADWAY MALYAN LANDSCAPE
Broadway Malyan Landscape Limited
Weybridge, Woking Hill, Addlestone
Weybridge, Surrey KT15 2XA
Telephone: 01832 845959 Fax: 01832 846043

LANDSCAPE: 871 Torquay Court Road
Reading: 10 High Street
Reading, Berkshire RG2 5AN
Telephone: 0118 982 2461
Southampton: 8 Southampton Street
Southampton, Hampshire SO2 2EJ
Telephone: 01703 330998 Fax: 01703 330996

MANCHESTER: 38 King Street
Manchester: 0161 819 2277 Fax: 0161 819 2382

Scale	Date	Drawn	Checked
1:200	JAN 99	A.S.S.	
JOB NO.	Drawing no.	Revision	
10027	101	A	

Client: Mr. John...
Project: ...

Existing Site

Proposed Development



Existing Site

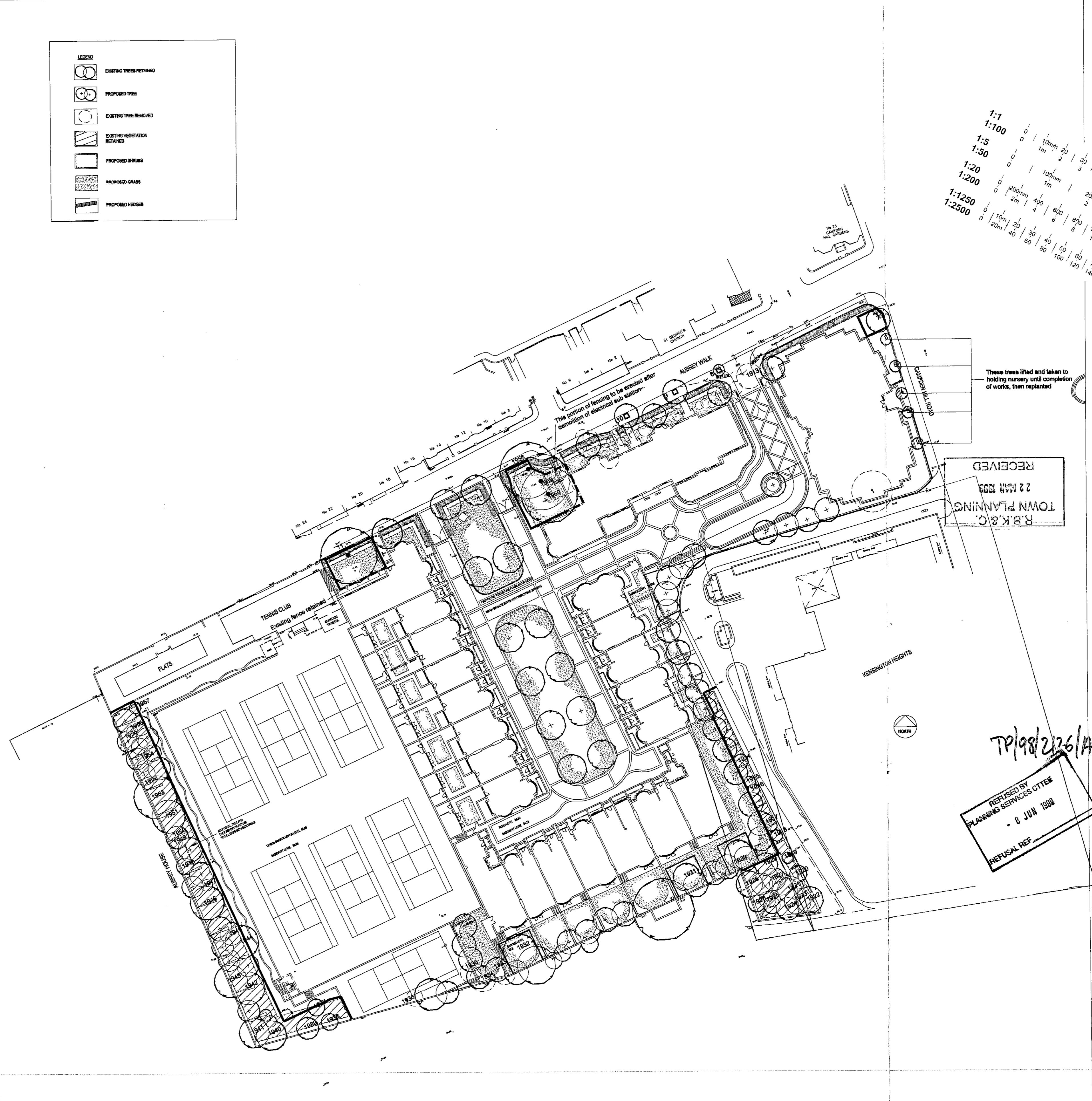
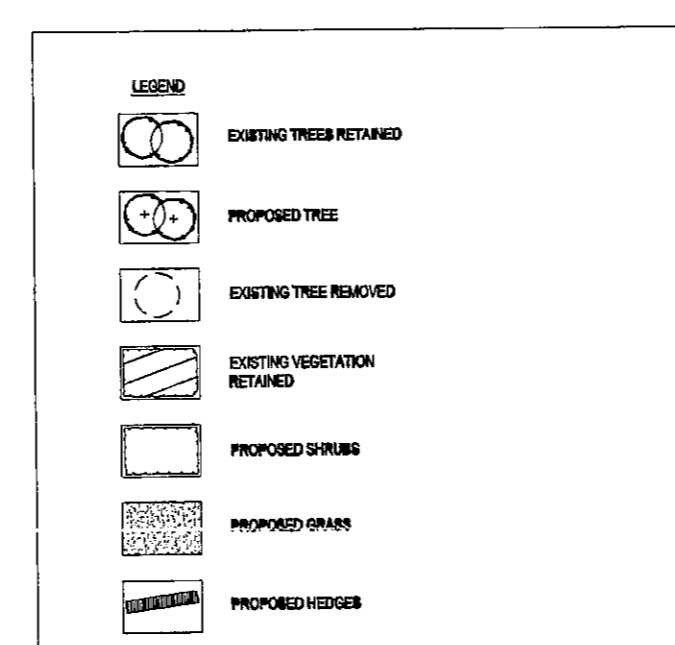

Proposed Development

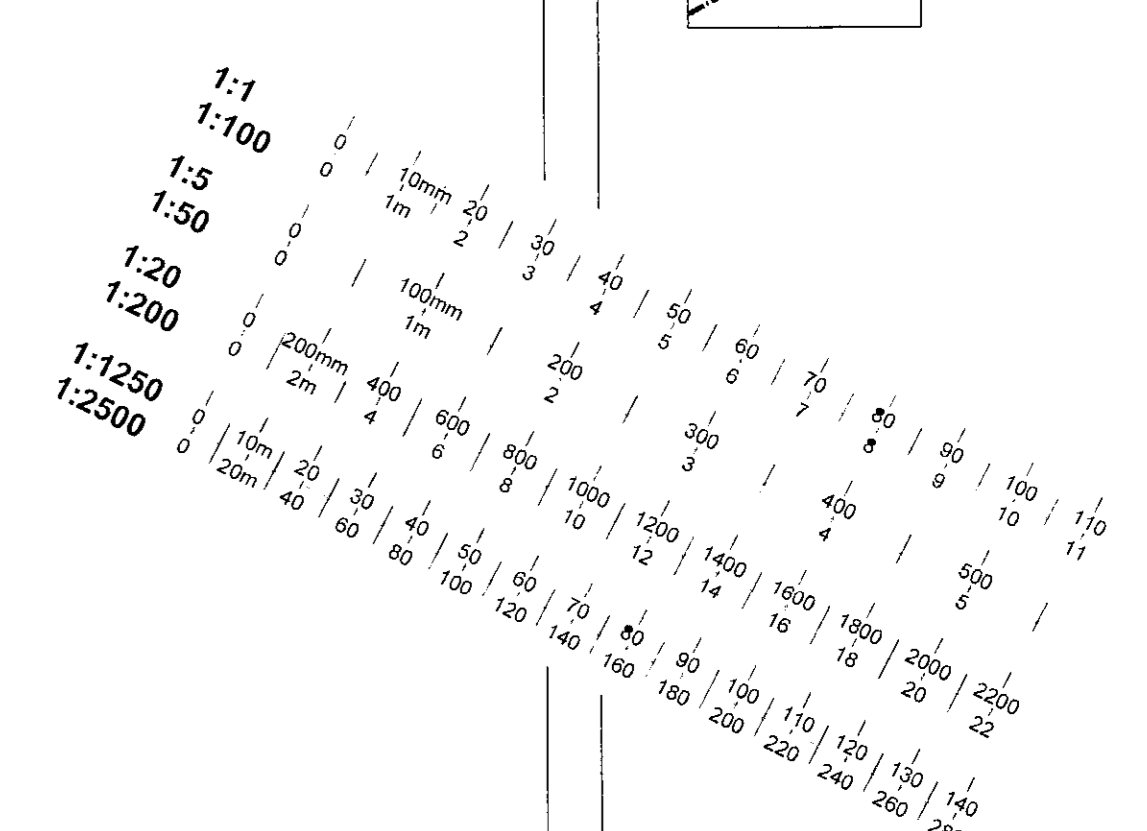

RECEIVED
22 JAN 99
TOWN PLANNING
R. J. K. & C.

7P/98/236/A
REFUSED BY
PLANNING SERVICES OFFICE
- 8 JUN 1998
REFUSAL REP.

CONTRACTORS ARE NOT TO SCALE
DIMENSIONS FROM THIS DRAWING

LEGEND
Protective fence in accordance with specification

REV	DATE	BY	DESCRIPTION
A	03.03.98	ABS	SCHEME UPDATED MINOR AMENDMENTS.
B	15.03.98	KC	SCHEME UPDATED.
C	17.03.98	KC	AUBREY WALK WALL REVISED

BROADWAY MALYAN LANDSCAPE
Broadway Malyan Landscape Limited

Weybridge: Woburn Hill, Addlestone
Weybridge, Surrey KT15 2QA
Telephone 01932 843389 Fax 0171 580 8464

London: 85 Tottenham Court Road
London W1P 9HD
Telephone 0171 580 5899 Fax 0171 580 8464

Reading: Ilex House, 10 High Street
Theale, Reading, Berkshire RG7 5AN
Telephone 0118 932 3455 Fax 0118 932 3461

Southampton: 8 Southampton Street
Southampton, Hampshire SO1 2ED
Telephone 01703 330808 Fax 01703 330886

Manchester: 36 King Street
Manchester, M2 6BA
Telephone 0161 819 2277 Fax 0161 819 2332

AUBREY WALK
CAMPDEN HILL RESERVOIR

ST JAMES HOMES

EXISTING TREE PROTECTION

Scale	Date	Drawn	Checked
1:500	JAN 99	A.B.S	

Job no.	Drawing no.	Revision
10337	101	C

Original size 100mm Broadway Malyan copyright

Received 23 AUG 2001 R.B.K.G.B.
 Planning Allocation

Contractors are not to scale dimensions from this drawing

Revision	Date
A. Scheme updated	ABS 03.02.99
B. Amendments to protective fence	ABS 03.04.99
C. Information updated	SL 30.11.99

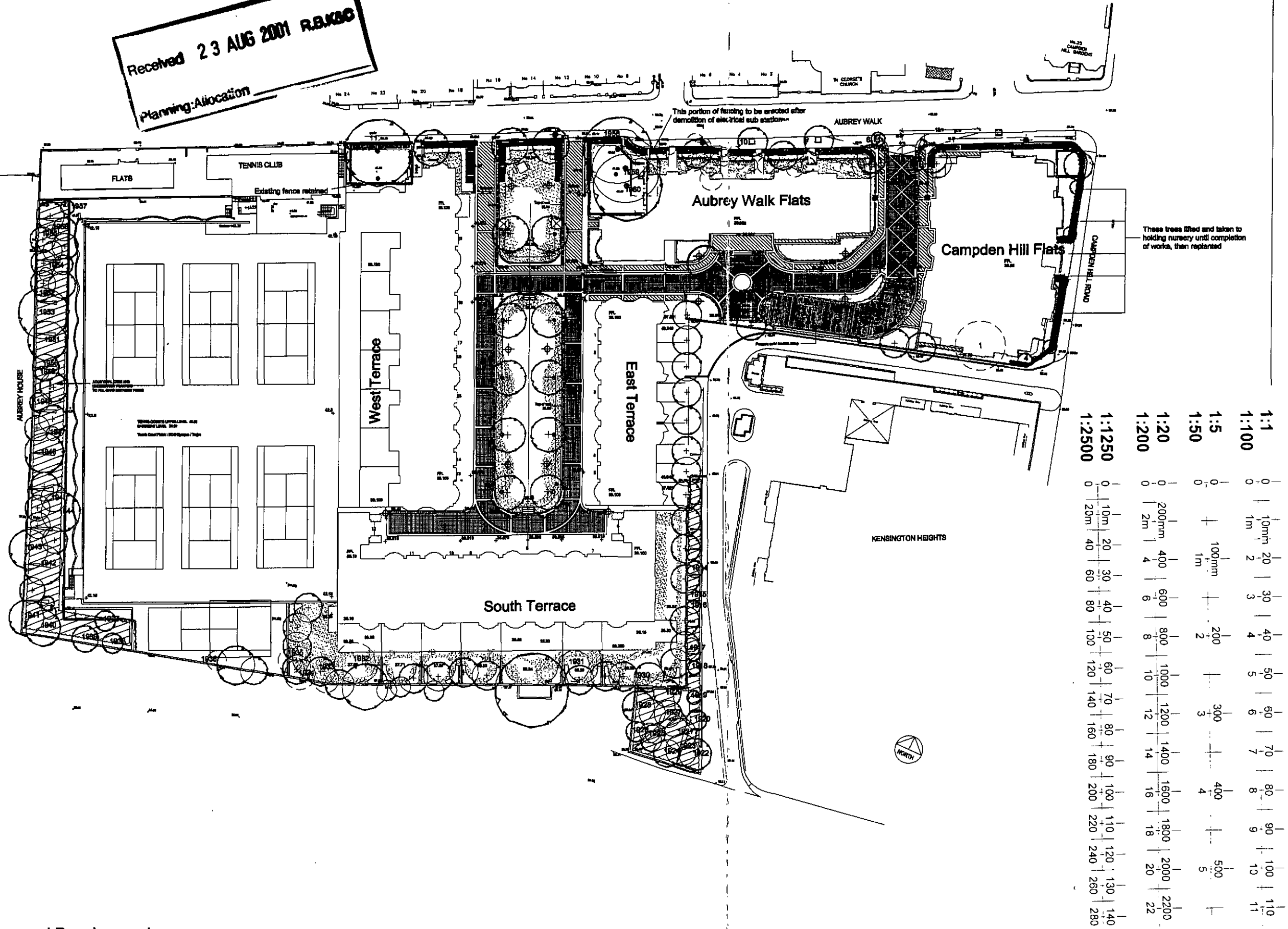

LEGEND

	PROTECTIVE FENCE IN ACCORDANCE WITH SPECIFICATION
	EXISTING TREE RETAINED
	PROPOSED TREE
	EXISTING TREE REMOVED
	EXISTING VEGETATION RETAINED
	PROPOSED SHRUBS
	PROPOSED GRASS
	PROPOSED HEDGES

1:1	0	10mm	20	30	40	50	60	70	80	90	100	110
1:100	0	1m	2	3	4	5	6	7	8	9	10	11
1:5	0	100mm	2	3	4	5	6	7	8	9	10	11
1:200	0	200mm	4	6	8	10	12	14	16	18	20	22
1:2500	0	20m	40	60	80	100	120	140	160	180	200	220
1:1250	0	10m	20	30	40	50	60	70	80	90	100	110
1:2500	0	20m	40	60	80	100	120	140	160	180	200	220

Proposed Development

BroadwayMalvan
 Landscape

Woburn Hill, Addlestone
 Weybridge, Surrey KT15 2QA
 T: +44(0)1932 845399
 F: +44(0)1932 846043
 E: Bm@broadwaymalvan.com

Client
St James Homes
 Project
Aubrey Walk
 Description
Existing Tree Protection

Scale	Drawn	Date
1:750	SA	Jan '99
Job number	Drawing number	Revision
10337	101_B	C

Original size 50mm Copyright Broadway Malvan Limited

RECEIVED
22 MAR 1999
TOWN PLANNING
R.B.K. & C.

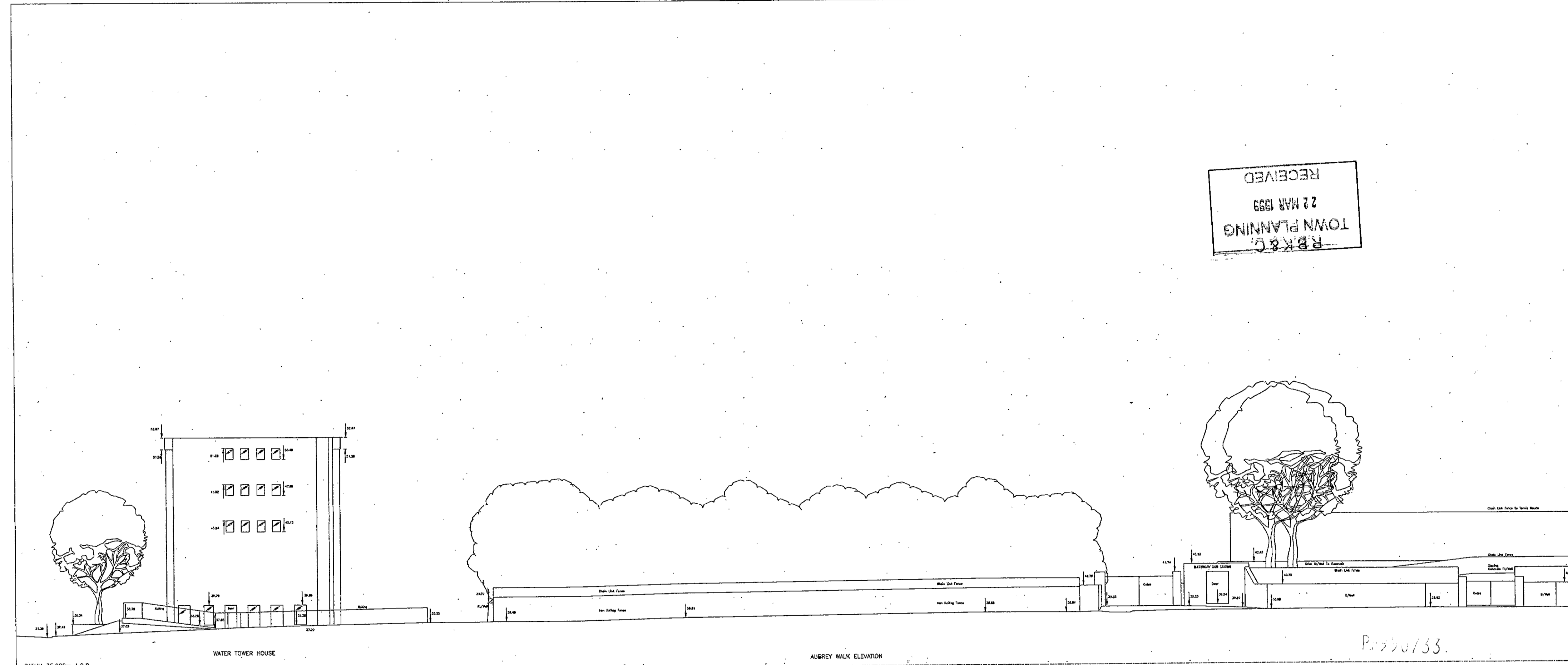

DATUM 35.000m A.O.D. WATER TOWER HOUSE AUBREY WALK ELEVATION

P2350/733

REFUSED BY
PLANNING SERVICE/DTL
- 8 JUN 2000
REFUSAL REF.

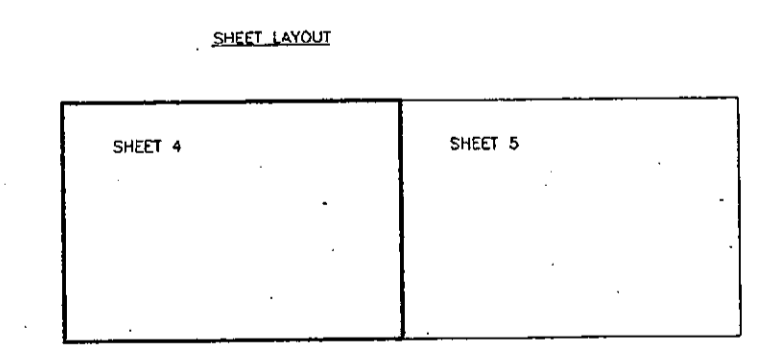

ALC DB
ANDREAS LAND SURVEYS & DATAGRAPHICS
123 Northwick Road, Northwick, London, N21 2JF
Tel: 0181 748519 Fax: 0181 748510
Web: 0181 448 0022 Fax: 0181 448 0028

Scale = 1:100
Drawing Number: 100
Client: R.B.K. & C.
Date: 02/99

Project:
CAMPDEN HILL ROAD
LONDON W8
AUBREY WALK - ELEVATIONS

Client:
ST. JAMES HOMES C/A BENELEY HOMES
WOLFELEANS
HIGH STREET
WESTON-SUPER-MARE

REDUCED FROM ORIGINAL TO 1:200

1:1	0	10mm	20	30	40	50	60	70	80	90	100	110			
1:100	0	1m	2	3	4	5	6	7	8	9	10	11			
1:5	0	100mm	200	300	400	500									
1:50	0	1m	2	3	4	5									
1:20	0	200mm	400	600	800	1000	1200	1400	1600	1800	2000	2200			
1:200	0	2m	4	6	8	10	12	14	16	18	20	22			
1:1250	0	10m	20	30	40	50	60	70	80	90	100	110	120	130	140
1:2500	0	20m	40	60	80	100	120	140	160	180	200	220	240	260	280

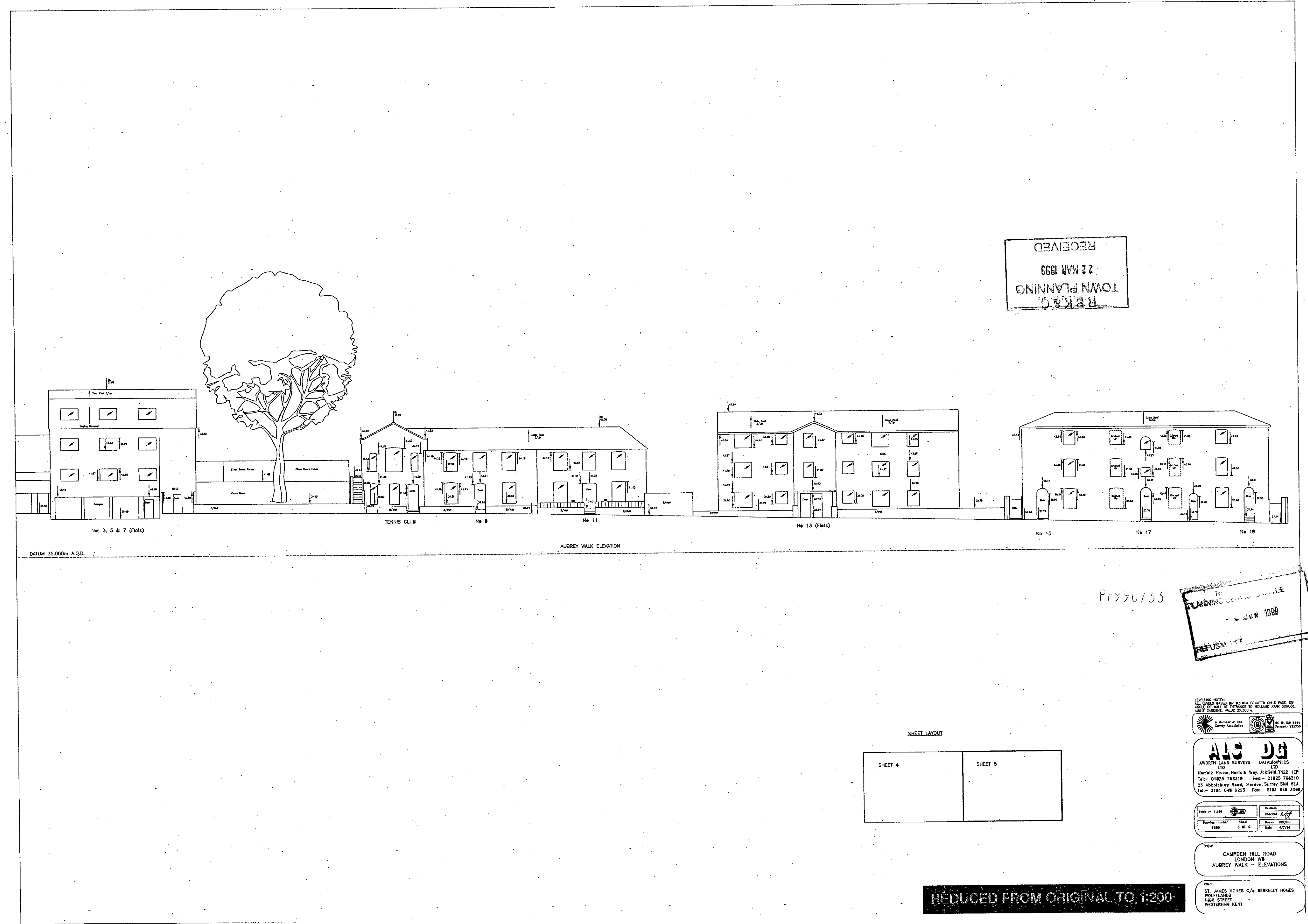

RECEIVED
22 MAR 1999
TOWN PLANNING
R.B.K.O.

P990733

RECEIVED
22 MAR 1999
TOWN PLANNING
R.B.K.O.

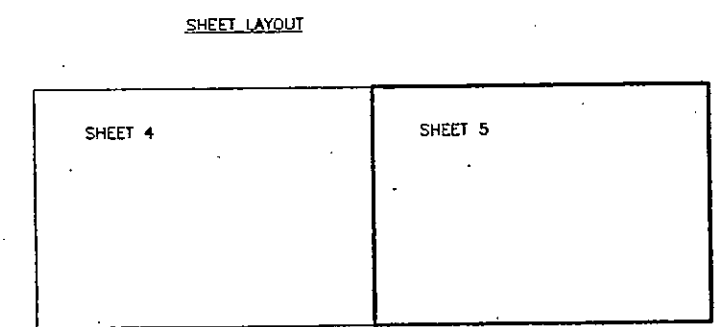

ALC DG
ANDREWS LAND SURVEYS
25 Abbotshay Road, Maidenhead, Surrey SL6 2SA
Tel: 01825 748318 Fax: 01825 748310
Tel: 0181 648 3223 Fax: 0181 648 3065

Project: CAMPDEN HILL ROAD LONDON W8 AUBREY WALK - ELEVATIONS

Client: ST. JAMES HOMES C/A BRINKLEY HOMES SOUTHGATE HIGH STREET WESTMINSTER HEATH

REDUCED FROM ORIGINAL TO 1:200

1:1	0	10mm	20	30	40	50	60	70	80	90	100	110			
1:100	0	1m	2	3	4	5	6	7	8	9	10	11			
1:5	0	100mm	200	300	400	500									
1:50	0	1m	2	3	4	5									
1:20	0	200mm	400	600	800	1000	1200	1400	1600	1800	2000	2200			
1:200	0	2m	4	6	8	10	12	14	16	18	20	22			
1:1250	0	10m	20	30	40	50	60	70	80	90	100	110	120	130	140
1:2500	0	120m	40	60	80	100	120	140	160	180	200	220	240	260	280

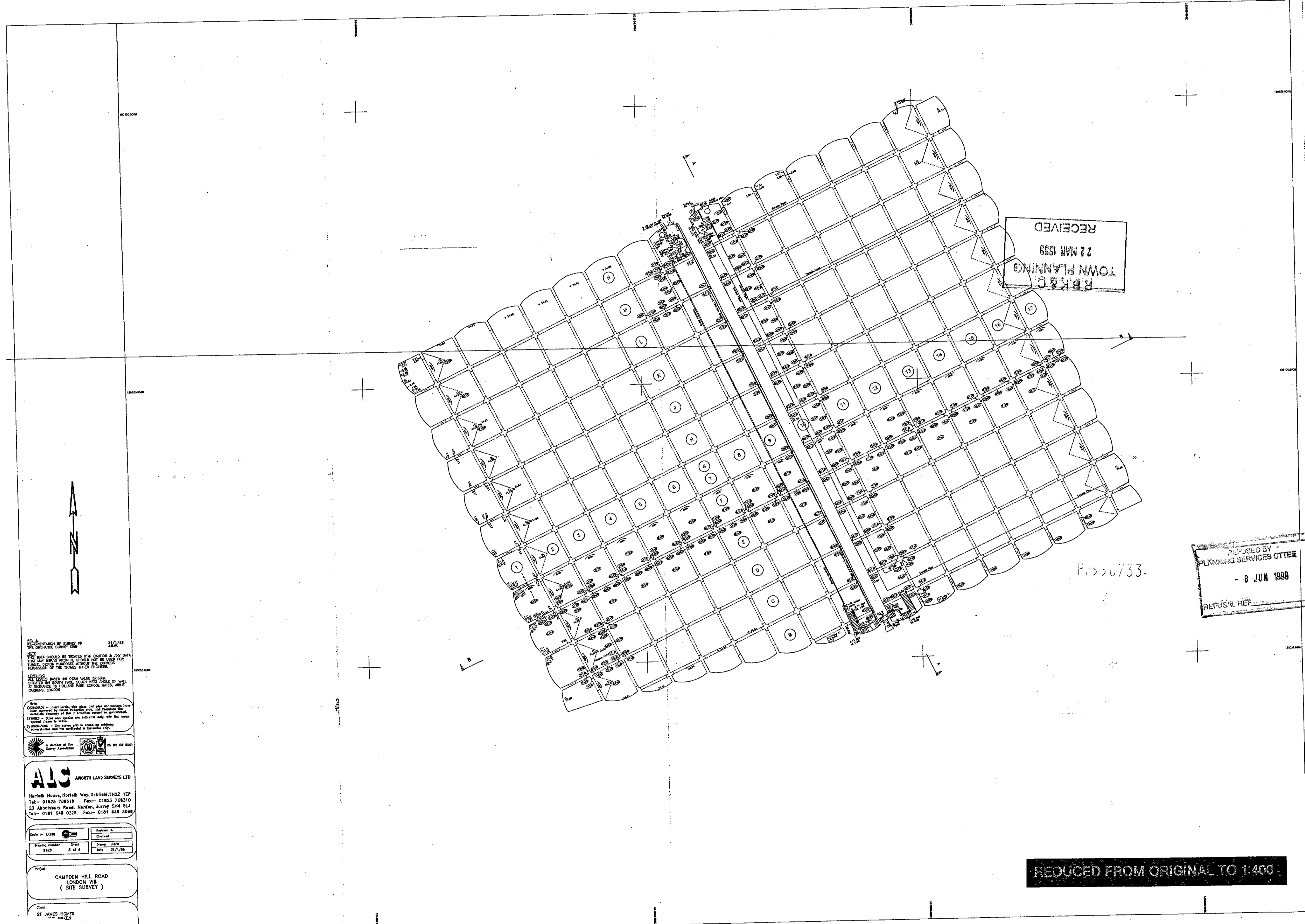

RECEIVED
 22 MAR 1999
 TOWN PLANNING
 R.B.K. & B.

REFUSED BY -
 PLANNING SERVICES OFFICE
 - 8 JUN 1999
 REFUSAL REF.

P990733

REDUCED FROM ORIGINAL TO 1:400

NOT TO SCALE
 THIS PLAN SHOULD BE VIEWED WITH CAUTION & NOT USED FOR ANY OTHER PURPOSES WITHOUT THE WRITTEN CONSENT OF THE SURVEYOR.
 THE SURVEYOR'S OFFICE IS NOT RESPONSIBLE FOR ANY DAMAGE TO OR LOSS OF PROPERTY OR PERSONS ARISING FROM THE USE OF THIS PLAN.

ALS NORTH LAND SURVEYS LTD
 25 ANCHORAGE ROAD, MARBLE HILL, DUBLIN 15
 TEL: 01-452 76218 FAX: 01-452 76210
 TEL: 01-452 76210 FAX: 01-452 76210

Project
 CAMPOEN HILL ROAD
 LONDON T8
 (SITE SURVEY)

Scale 1:400
 Date 22/01/99
 Drawn J.M.P.
 Checked J.M.P.

1:1	0	10mm	20	30	40	50	60	70	80	90	100	110			
1:100	0	1m	2	3	4	5	6	7	8	9	10	11			
1:5	0	100mm	200	300	400	500									
1:50	0	1m	2	3	4	5									
1:20	0	200mm	400	600	800	1000	1200	1400	1600	1800	2000	2200			
1:200	0	2m	4	6	8	10	12	14	16	18	20	22			
1:1250	0	10m	20	30	40	50	60	70	80	90	100	110	120	130	140
1:2500	0	20m	40	60	80	100	120	140	160	180	200	220	240	260	280

REVISIONS

NO.	DESCRIPTION	DATE
1	ISSUED FOR PERMIT	22 MAR 1999
2	ISSUED FOR TOWN PLANNING	22 MAR 1999

LEGEND

Symbol	Line Style	DESCRIPTION
...	---	...
...	---	...

Coordinate Table

LINE	START	END	N	E	UNIT
1	10	11	100000	200000	M
1	11	12	100000	200000	M
1	12	13	100000	200000	M
1	13	14	100000	200000	M
1	14	15	100000	200000	M
1	15	16	100000	200000	M
1	16	17	100000	200000	M
1	17	18	100000	200000	M
1	18	19	100000	200000	M
1	19	20	100000	200000	M

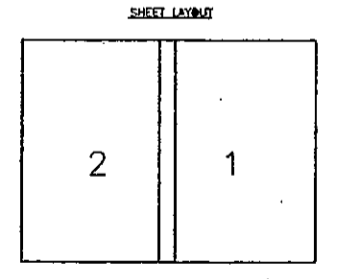

PROVISIONS
THE PLAN SHOULD BE READ IN CONJUNCTION WITH THE STANDARD DRAWING CONDITIONS.

NOTES
1. THIS PLAN SHOULD BE READ IN CONJUNCTION WITH THE STANDARD DRAWING CONDITIONS.
2. THE PROPERTY SHOWN ON THIS PLAN IS OWNED BY THE CAMDEN HILL RESERVOR TRUST.
3. THE PLAN IS BASED ON THE SURVEY DATED 20 MAR 1999.
4. THE PLAN IS SUBJECT TO ALL RIGHTS OF WAY AND EASEMENTS.
5. THE PLAN IS SUBJECT TO ALL PLANNING CONTROLS.
6. THE PLAN IS SUBJECT TO ALL LEGAL OBSTACLES.
7. THE PLAN IS SUBJECT TO ALL ADVERSE CLAIMS.
8. THE PLAN IS SUBJECT TO ALL UNDISCOVERED OBSTACLES.
9. THE PLAN IS SUBJECT TO ALL UNDISCOVERED CLAIMS.
10. THE PLAN IS SUBJECT TO ALL UNDISCOVERED OBSTACLES.

ALS
ARTHUR LAND SURVEYS LTD
Northolt House, Northolt, Wyo. Uxbridge, Mx9 2LP
Tel: 01825 748519 Fax: 01825 748510
22 Abchurch Lane, Market, Surrey S4 4JZ
Tel: 0181 646 0223 Fax: 0181 646 0209

Scale 1:1000
1:500
1:200
1:1250
1:2500

Project: CAMDEN HILL RESERVOR SITE SURVEY

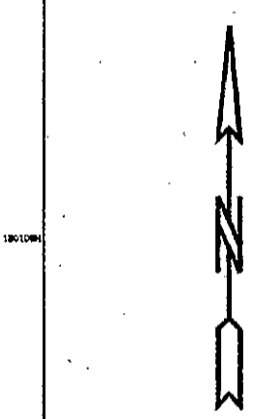
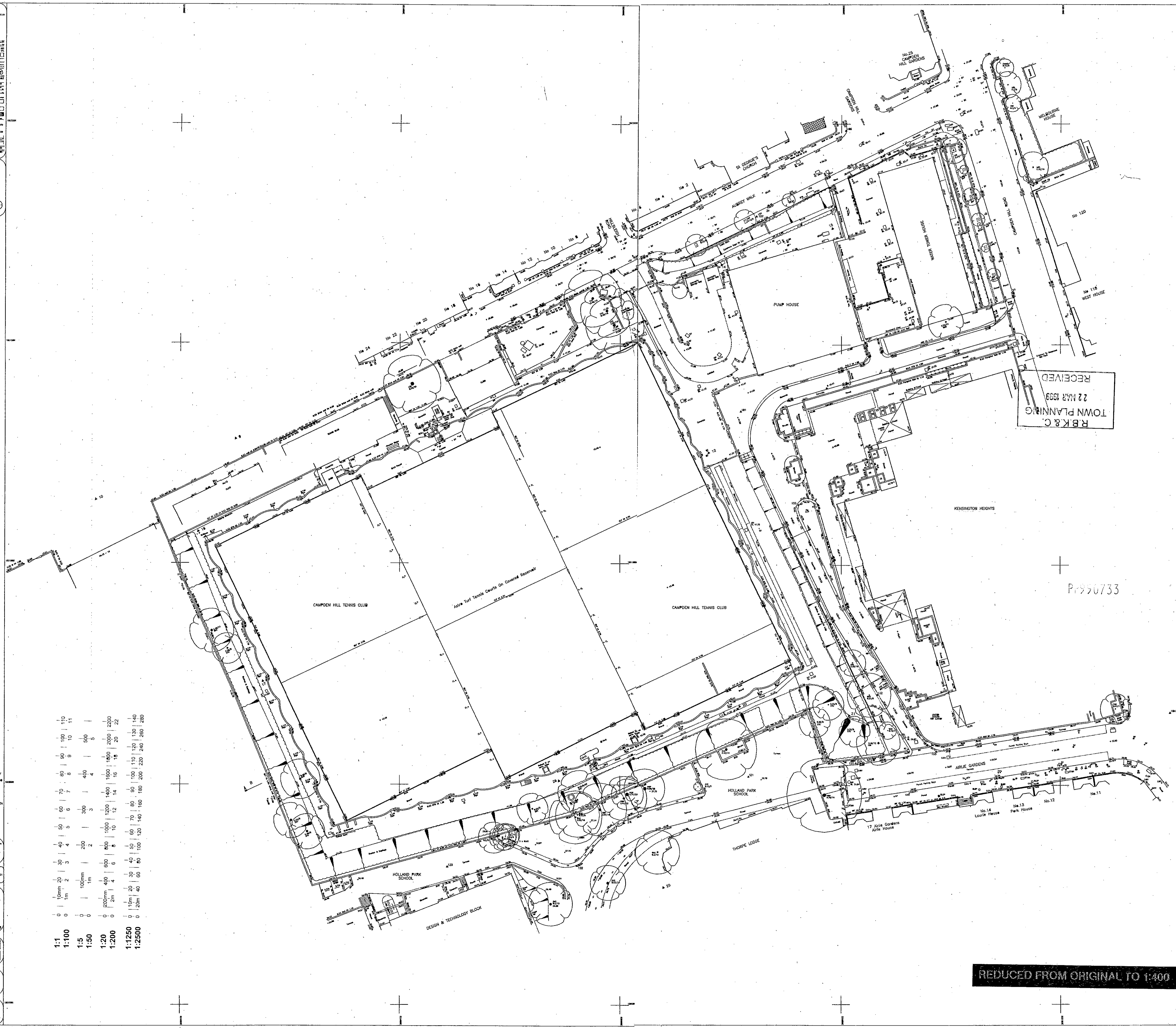

REFUSED BY
LAKERS SERVICES OFFICE
- 8 JUN 1999
REFUSAL REF.

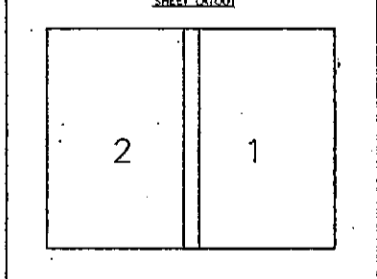

PROVISIONS
THE PLAN SHOULD BE READ IN CONJUNCTION WITH THE STANDARD DRAWING CONDITIONS.

NOTES
1. THIS PLAN SHOULD BE READ IN CONJUNCTION WITH THE STANDARD DRAWING CONDITIONS.
2. THE PROPERTY SHOWN ON THIS PLAN IS OWNED BY THE CAMDEN HILL RESERVOR TRUST.
3. THE PLAN IS BASED ON THE SURVEY DATED 20 MAR 1999.
4. THE PLAN IS SUBJECT TO ALL RIGHTS OF WAY AND EASEMENTS.
5. THE PLAN IS SUBJECT TO ALL PLANNING CONTROLS.
6. THE PLAN IS SUBJECT TO ALL LEGAL OBSTACLES.
7. THE PLAN IS SUBJECT TO ALL ADVERSE CLAIMS.
8. THE PLAN IS SUBJECT TO ALL UNDISCOVERED OBSTACLES.
9. THE PLAN IS SUBJECT TO ALL UNDISCOVERED CLAIMS.
10. THE PLAN IS SUBJECT TO ALL UNDISCOVERED OBSTACLES.

ALS
ARTHUR LAND SURVEYS LTD
Northolt House, Northolt, Wyo. Uxbridge, Mx9 2LP
Tel: 01825 748519 Fax: 01825 748510
22 Abchurch Lane, Market, Surrey S4 4JZ
Tel: 0181 646 0223 Fax: 0181 646 0209

Scale 1:1000
1:500
1:200
1:1250
1:2500

Project: CAMDEN HILL RESERVOR SITE SURVEY

REDUCED FROM ORIGINAL TO 1:400

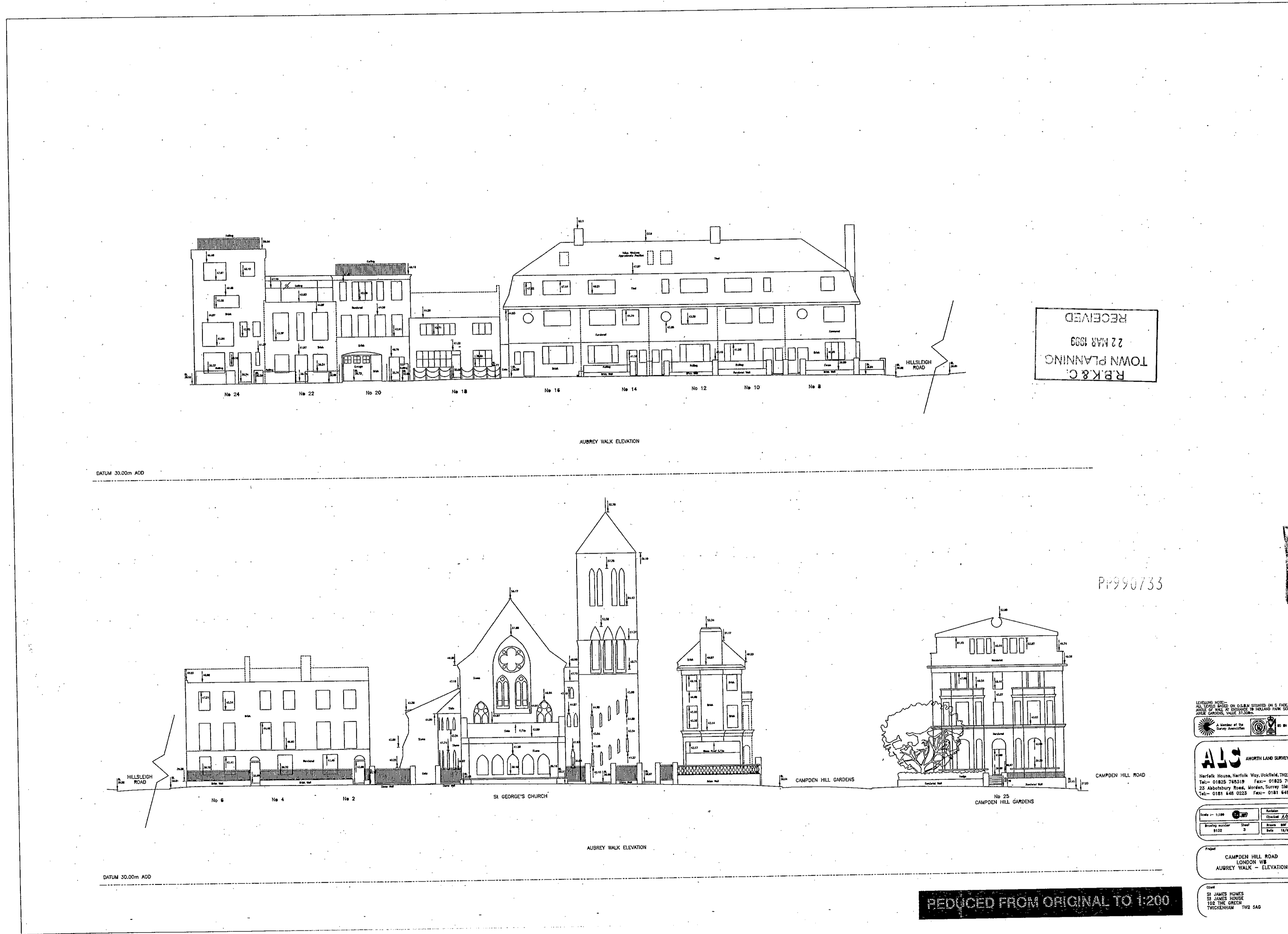

RECEIVED
 22 MAR 1999
 TOWN PLANNING
 R.P.K. & C.

REFUSED BY
 PLANNING SERVICES OFFICE
 - 8 JUN 1999
 REFUSAL REF.

P/990733

THIS DRAWING IS THE PROPERTY OF THE SURVEYOR AND IS NOT TO BE REPRODUCED OR TRANSMITTED IN ANY FORM OR BY ANY MEANS, ELECTRONIC OR MECHANICAL, WITHOUT THE WRITTEN PERMISSION OF THE SURVEYOR.

ALS ARKOTH LAND SURVEYS LTD
 22 Abchurch Lane, London, EC4A 3DF
 Tel: 0181 448 0223 Fax: 0181 448 3595

Scale: 1:200
 Drawing No: 9119
 Date: 15/06/98

Project: CAMPDEN HILL ROAD LONDON W8 AUBREY WALK - ELEVATION

Client: ST JAMES HOUSE 100 THE GREEN WINDHAM - W12 5AG

REDUCED FROM ORIGINAL TO 1:200

1:1	0	10mm	20	30	40	50	60	70	80	90	100	110			
1:100	0	1m	2	3	4	5	6	7	8	9	10	11			
1:5	0	100mm	200	300	400	500									
1:50	0	1m	2	3	4	5									
1:20	0	200mm	400	600	800	1000	1200	1400	1600	1800	2000	2200			
1:200	0	2m	4	6	8	10	12	14	16	18	20	22			
1:1250	0	10m	20	30	40	50	60	70	80	90	100	110	120	130	140
1:2500	0	20m	40	60	80	100	120	140	160	180	200	220	240	260	280

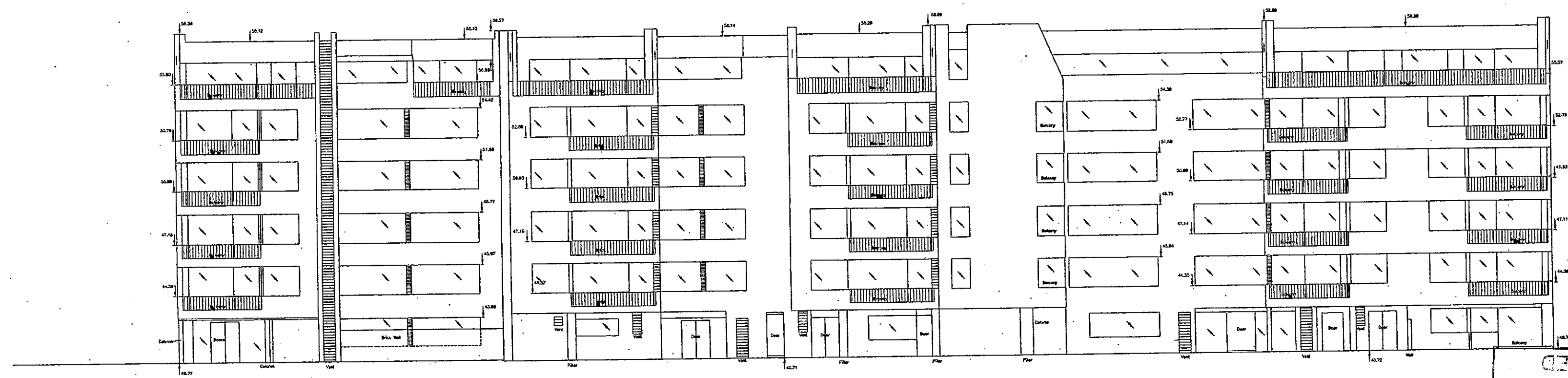

KENSINGTON HEIGHTS ELEVATION

RECEIVED
 22 JUN 2009
 TOWN PLANNING
 R.P. 22

DATUM 30.00m A.O.D.



AIRLE GARDENS

THORPE LODGE

DATUM 30.00m A.O.D.

P/99/0733

REFUSED BY
 PLANNING SERVICES CITEE
 - 8 JUN 2009
 REFUSAL REF

INCLOSURE: THIS DRAWING IS THE PROPERTY OF AIRLE GARDENS AND SHOULD NOT BE REPRODUCED OR COPIED WITHOUT THE WRITTEN PERMISSION OF AIRLE GARDENS. REF: 08/04

ALS AIRLE LAND SURVEYS LTD
 11 North Street, Harlow, Essex, SSG11 2JF
 Tel: 01276 748318 Fax: 01276 748310
 25 Abchurch Lane, London, EC4A 3DF
 Tel: 0181 440 0223 Fax: 0181 440 2055

Scale: 1:100
 Drawing Number: 99/0733
 Date: 10/06/09

Project: CAMPDEN HILL ROAD, LONDON, W8, KENSINGTON HEIGHTS-AIRLE GARDENS

Client: ST JAMES HOUSE, 14 JAMES HOUSE, 102 THE GREEN, WOODHURST, W19 5AG

REDUCED FROM ORIGINAL TO 1:200

1:1	0	10mm	20	30	40	50	60	70	80	90	100	110			
1:100	0	1m	2	3	4	5	6	7	8	9	10	11			
1:5	0	100mm	200	300	400	500									
1:50	0	1m	2	3	4	5									
1:20	0	200mm	400	600	800	1000	1200	1400	1600	1800	2000	2200			
1:200	0	2m	4	6	8	10	12	14	16	18	20	22			
1:1250	0	10m	20	30	40	50	60	70	80	90	100	110	120	130	140
1:2500	0	20m	40	60	80	100	120	140	160	180	200	220	240	260	280

1:1	0	10mm	20	30	40	50	60	70	80	90	100	110
1:100	0	1m	2	3	4	5	6	7	8	9	10	11
1:5	0	100mm	200	300	400	500						
1:50	0	2m	4	6	8	10						
1:20	0	200mm	400	600	800	1000	1200	1400	1600	1800	2000	2200
1:200	0	2m	4	6	8	10	12	14	16	18	20	22
1:1250	0	10m	20	30	40	50	60	70	80	90	100	110
1:2500	0	20m	40	60	80	100	120	140	160	180	200	220

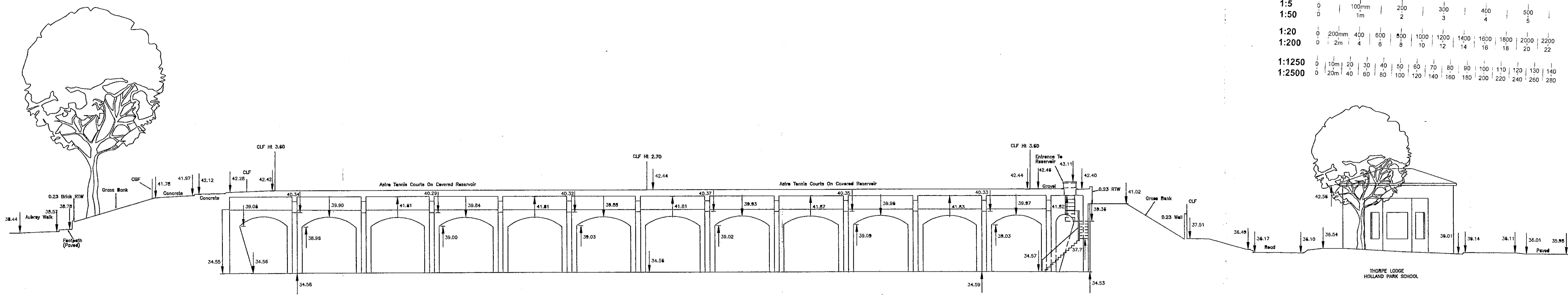

Datum 30.000m A.O.D. Datum 30.000m A.O.D.

Section A-A

RECEIVED
22 MAR 1999
R.B.K. & C.
TOWN PLANNING

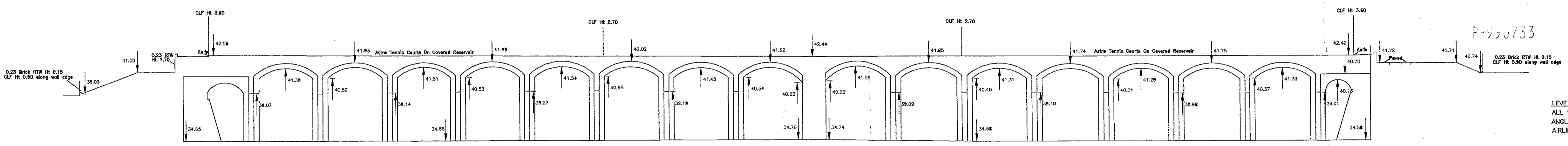

Datum 30.000m A.O.D. Datum 30.000m A.O.D.

Section B-B

REFUSED BY
PLANNING SERVICES CITEE
- 8 JUN 1999
REFUSAL REF

LEVELLING NOTE:-
ALL LEVELS BASED ON O.S.B.M SITUATED ON S FACE, SW
ANGLE OF WALL AT ENTRANCE TO HOLLAND PARK SCHOOL,
AIRLIE GARDENS, VALUE 37.300m.



ALS AWORTH LAND SURVEYS LTD
Norfolk House, Norfolk Way, Uckfield, TN22 1EP
Tel:- 01825 768319 Fax:- 01825 768310
23 Abbotsbury Road, Morden, Surrey SM4 5LJ
Tel:- 0181 648 0223 Fax:- 0181 646 3068

Scale 1:- 1/200	Revision
Drawing number 9029	Checked
Sheet 4 of 4	Drawn J.B.W
	Date 21/1/98

Project
CAMPDEN HILL ROAD
LONDON W8
(SITE SURVEY)

Client
ST JAMES HOMES
102 THE GREEN
TWICKENHAM
MIDDLESEX TW2 5AG

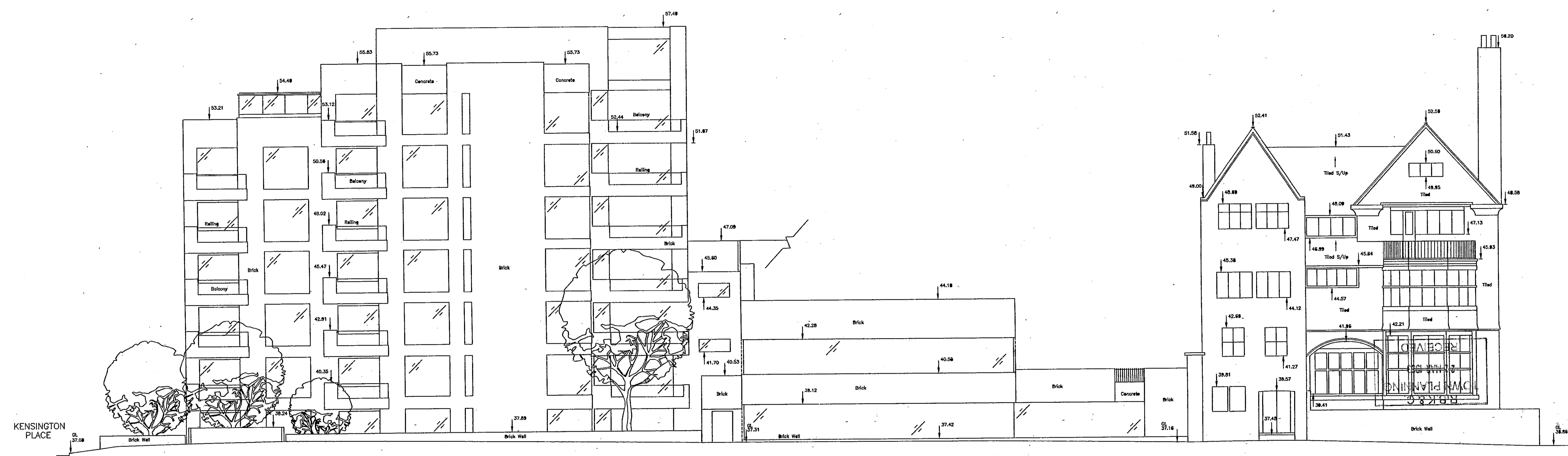

KENSINGTON PLACE
 MELBOURNE HOUSE
 No 120
 WEST HOUSE No 118
 CAMPDEN HILL ROAD

DATUM 30.00m AOD

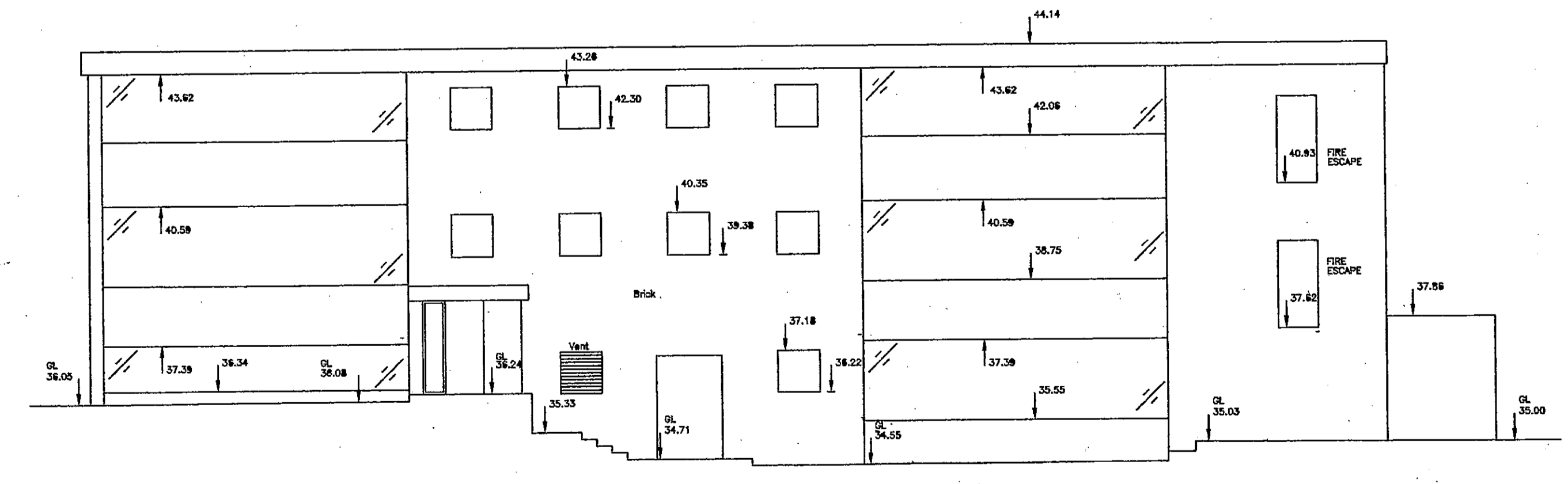
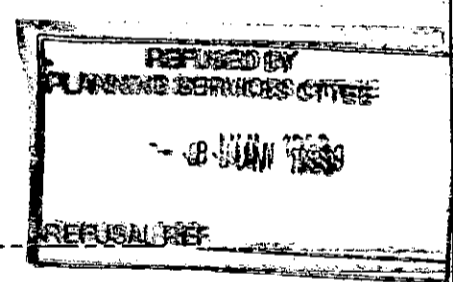

DESIGN & TECHNOLOGY BLOCK
 DATUM 30.00m AOD

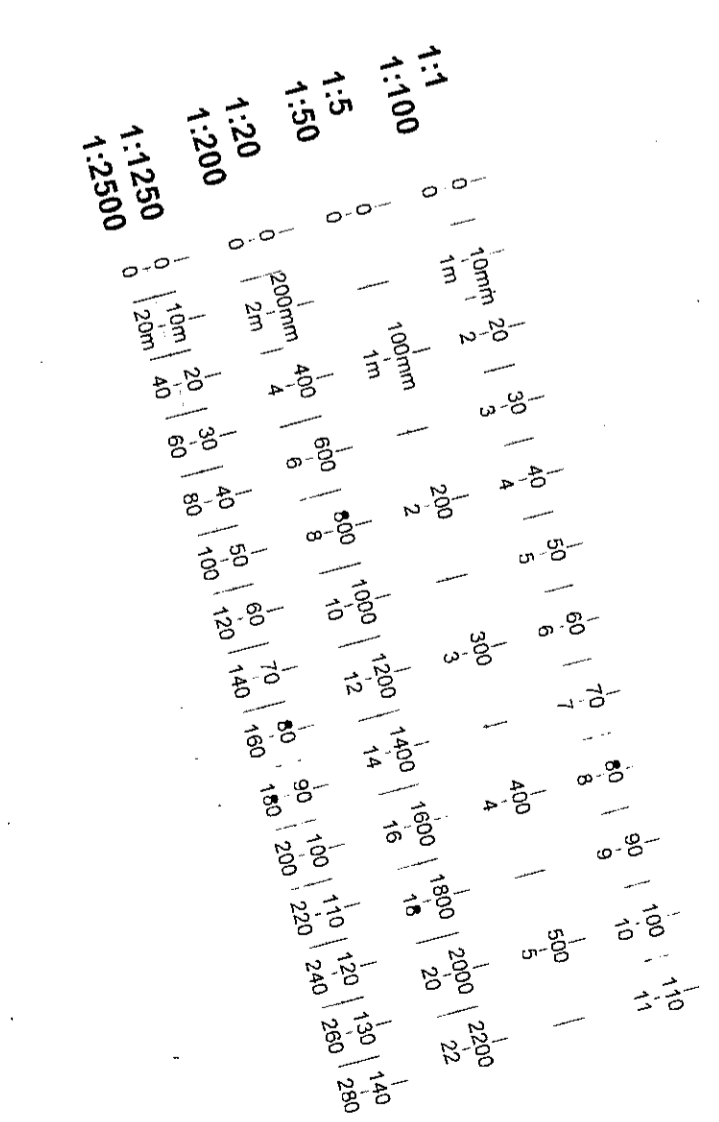

LEVELLING NOTE:-
 ALL LEVELS BASED ON O.S.B.M SITUATED ON S FACE, SW ANGLE OF WALL AT ENTRANCE TO HOLLAND PARK SCHOOL, AIRLIE GARDENS, VALUE 37.300m.

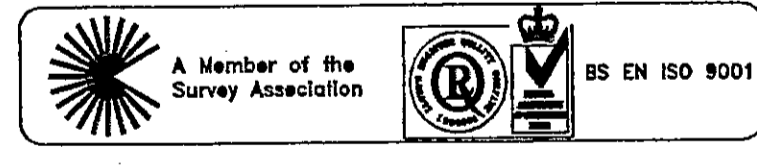

ALS AWORTH LAND SURVEYS LTD

Norfolk House, Norfolk Way, Uckfield, TN22 1EP
 Tel:- 01825 768319 Fax:- 01825 768310
 23 Abbotsbury Road, Morden, Surrey SM4 5LJ
 Tel:- 0181 648 0223 Fax:- 0181 646 3068

Scale :- 1:100	Revision
Drawing number 9132	Sheet 5
Drawn DRF/JBW	Date 18/6/98

Project
 CAMPDEN HILL ROAD
 LONDON W8
 ELEVATIONS

Client
 St JAMES HOMES
 St JAMES HOUSE
 102 THE GREEN
 TWICKENHAM TW2 5AG

Status

Contractors are not to scale dimensions from this drawing

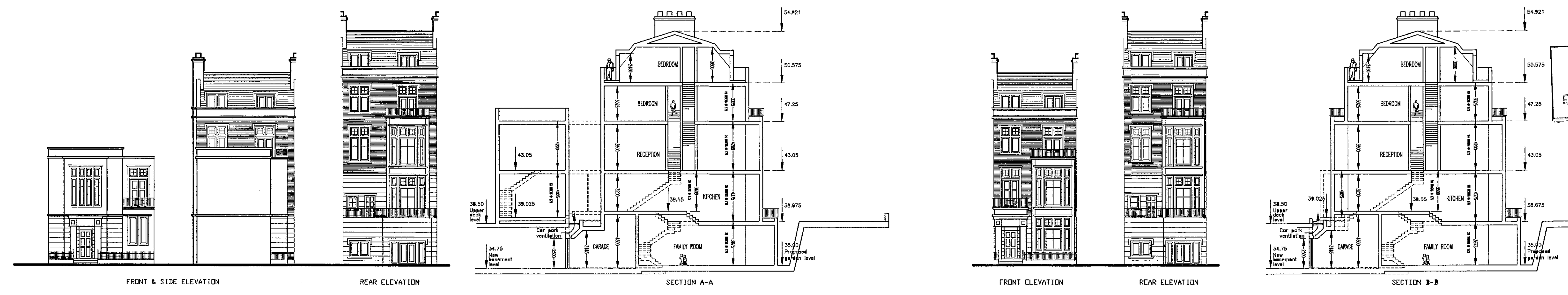
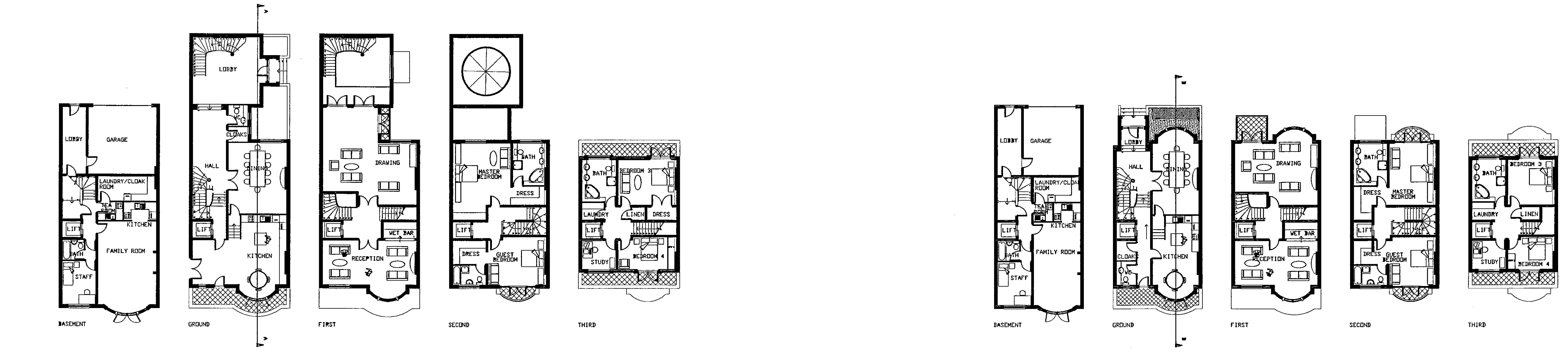
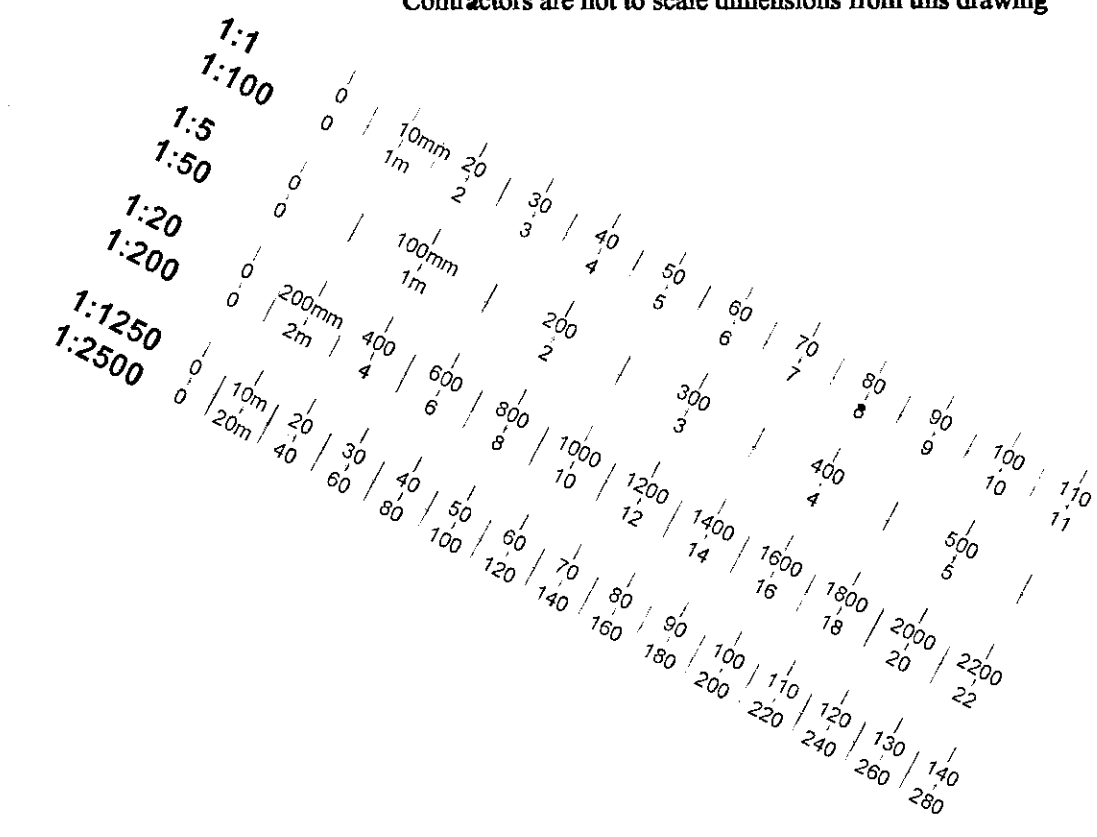

RECEIVED
22 MAR 1999
TOWN PLANNING
R.B.K. & C.

REVISIONS
A: Elevations and key plan updated 16/3/99.

HOUSE TYPE H

HOUSE TYPE J

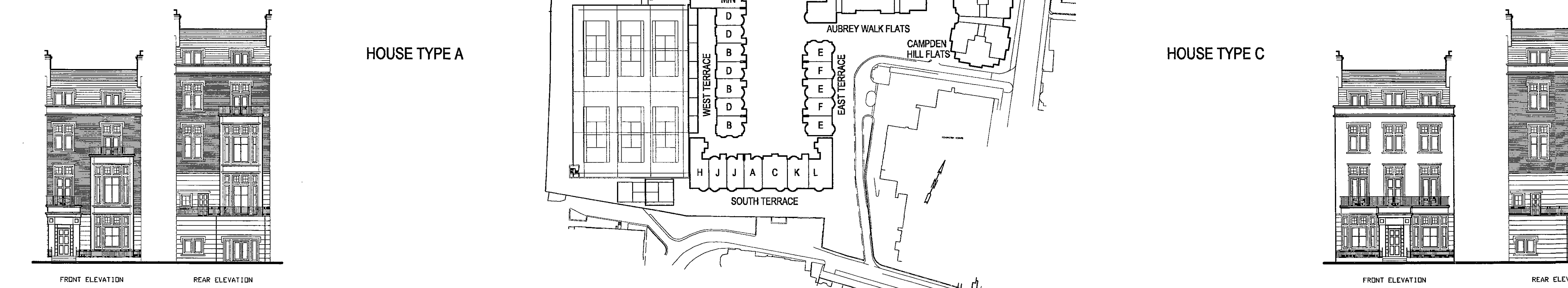
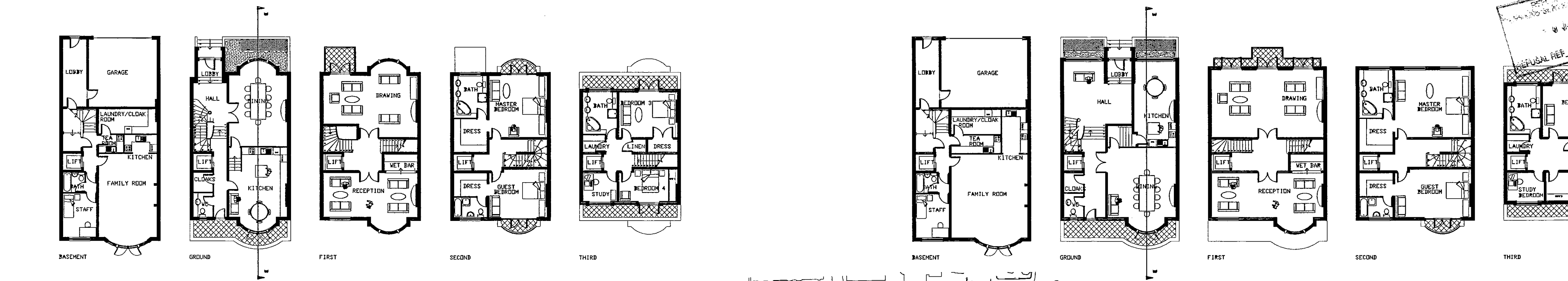

HOUSE TYPE A

HOUSE TYPE C

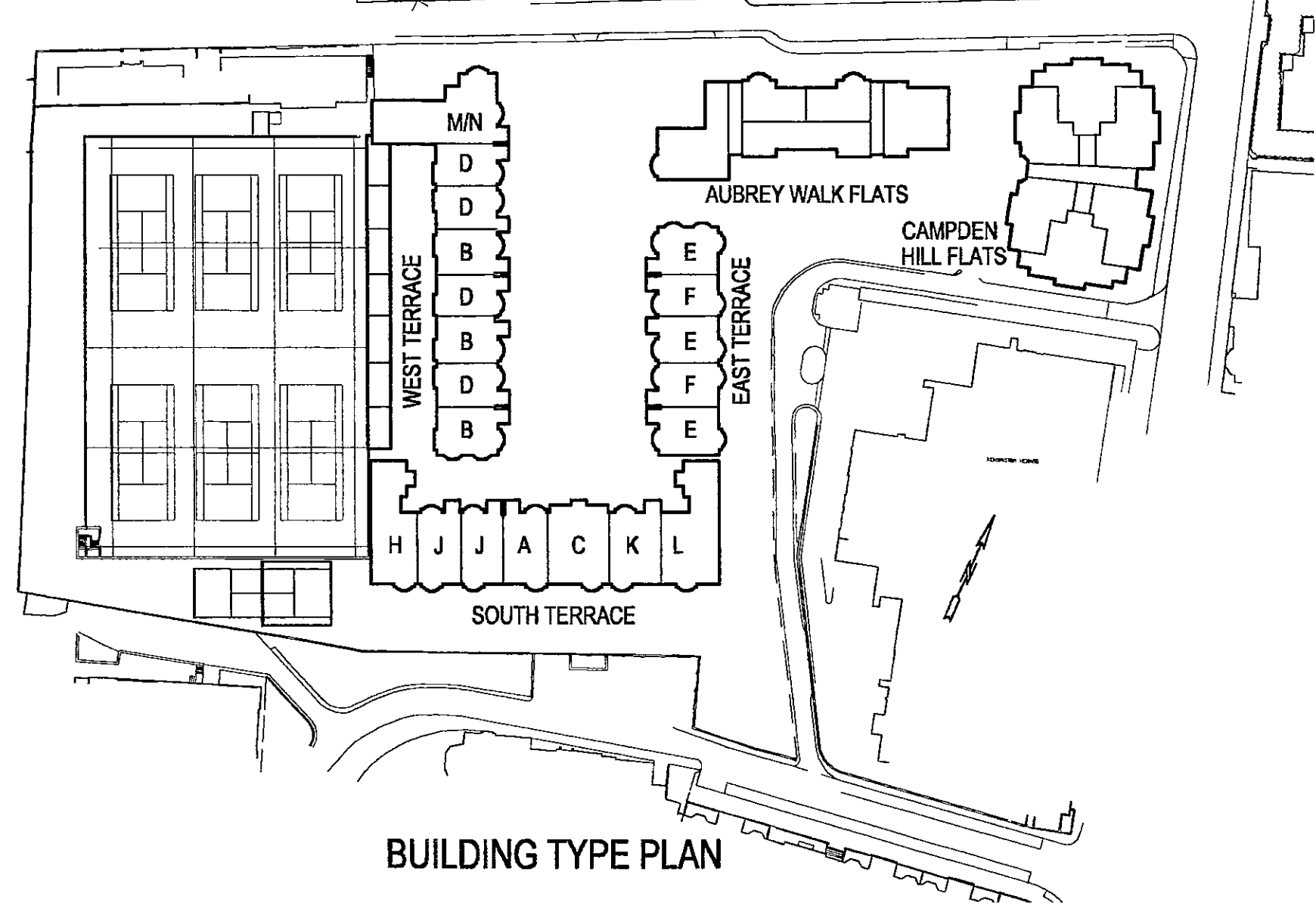

BUILDING TYPE PLAN

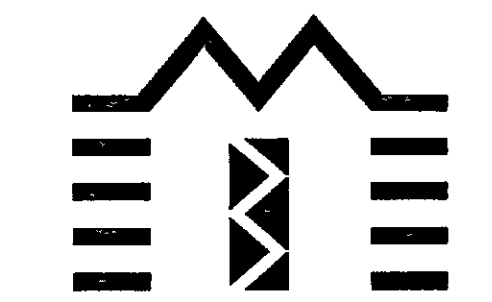

BROADWAY MALYAN ARCHITECTS

Broadway Malyan Chartered Architects
 Weybridge: Woburn Hill, Addlestone Weybridge, Surrey KT15 2QA Telephone 01932 845599 Fax 01932 856206
 London: 85 Tottenham Court Road London W1P 9HD Telephone 0171 580 5999 Fax 0171 580 8464
 Reading: Ilex House, 10 High Street Theale, Reading, Berkshire RG7 5AN Telephone 01189 323456 Fax 01189 932461
 Southampton: 8 Southampton Street Southampton, Hampshire SO15 2ED Telephone 01703 330808 Fax 01703 330986

Aubrey Walk
Campden Hill Reservoir

St James Homes

House Plans A C H J,
Elevations & Sections

Scale	Date	Drawn
1:200	02/11/98	AC
Job No	Drawing No	Revision
7650	P108	A

Status

Contractors are not to scale dimensions from this drawing



GROUND FLOOR

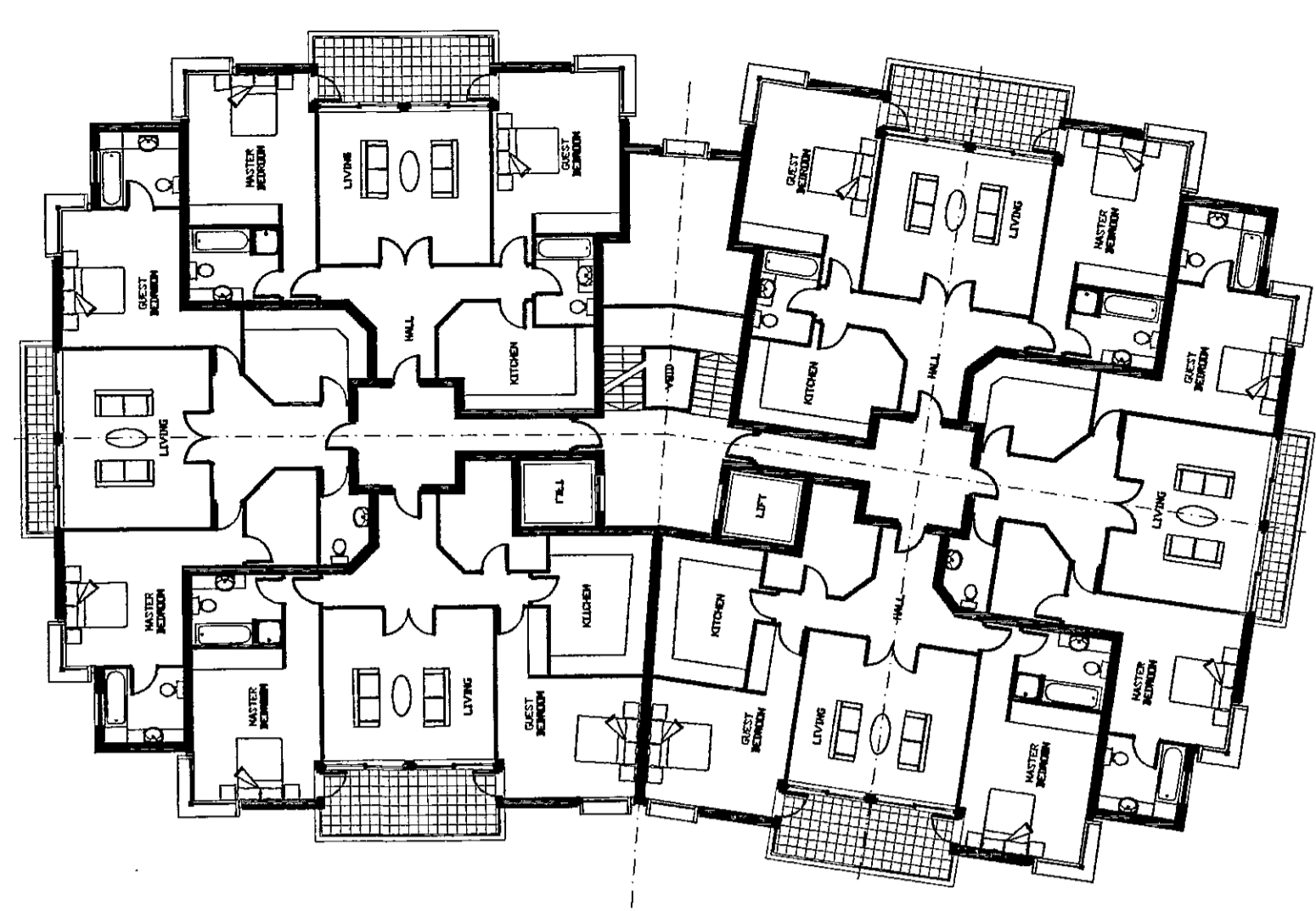

SECOND FLOOR

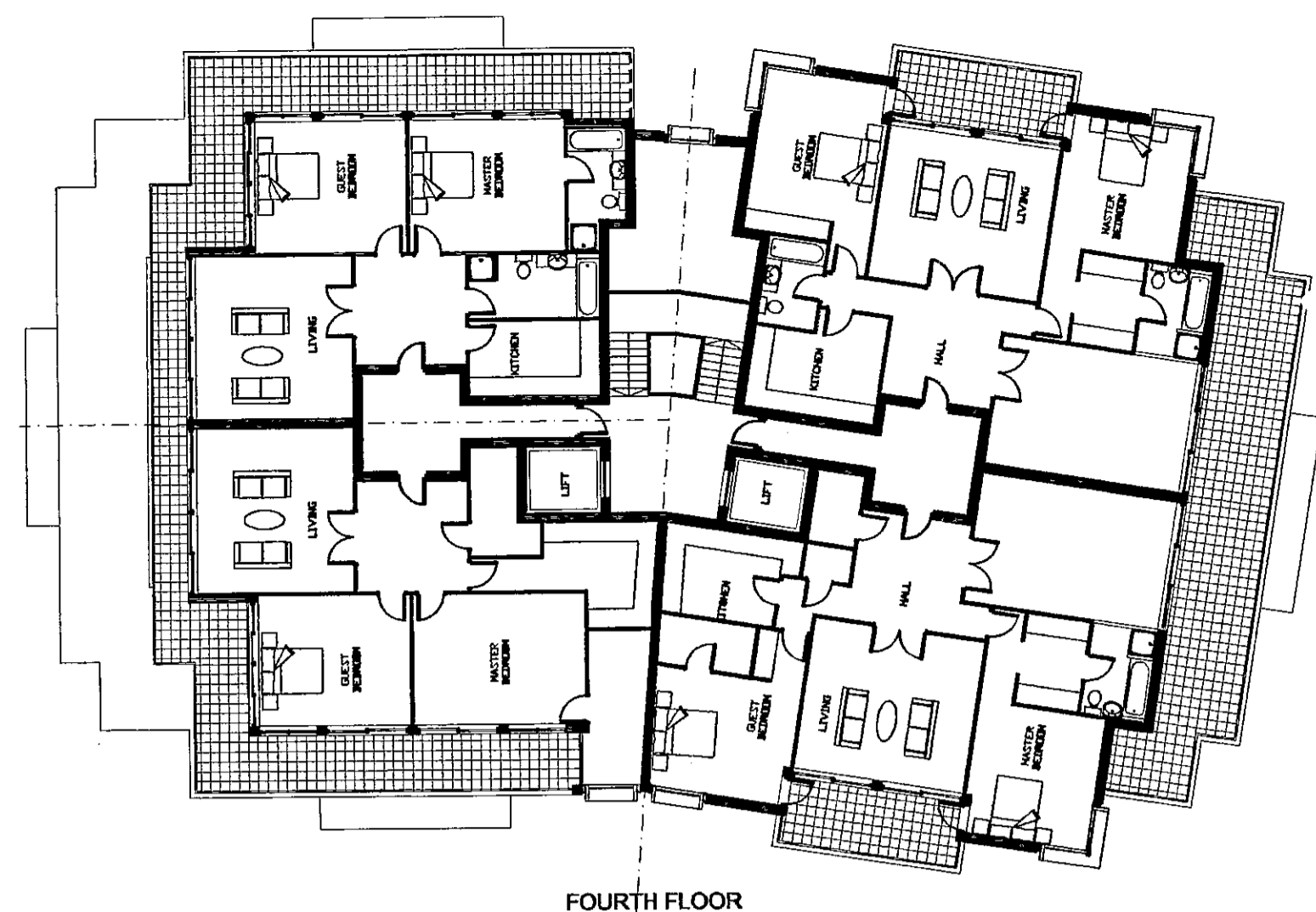

FOURTH FLOOR

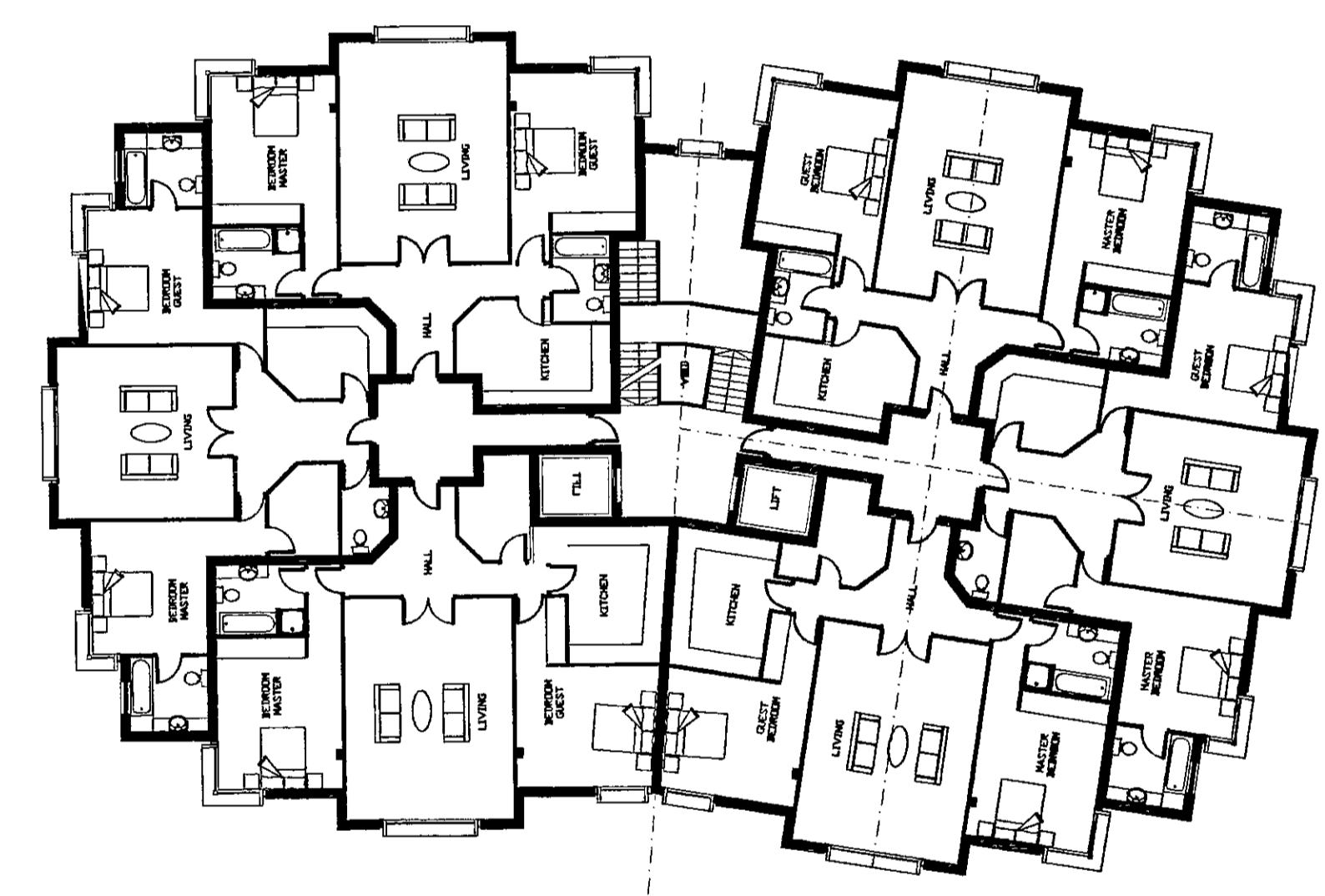

FIRST FLOOR

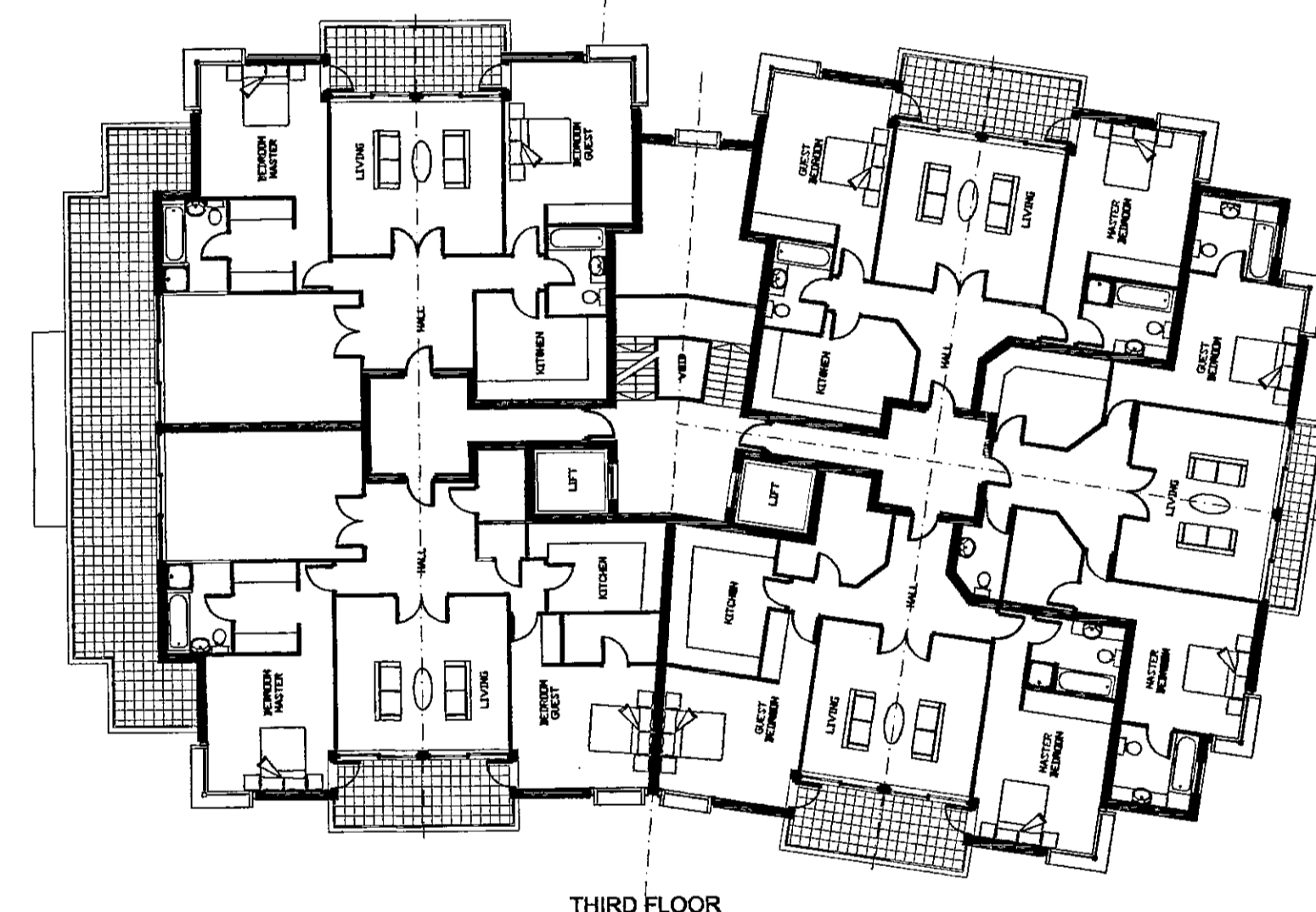

THIRD FLOOR

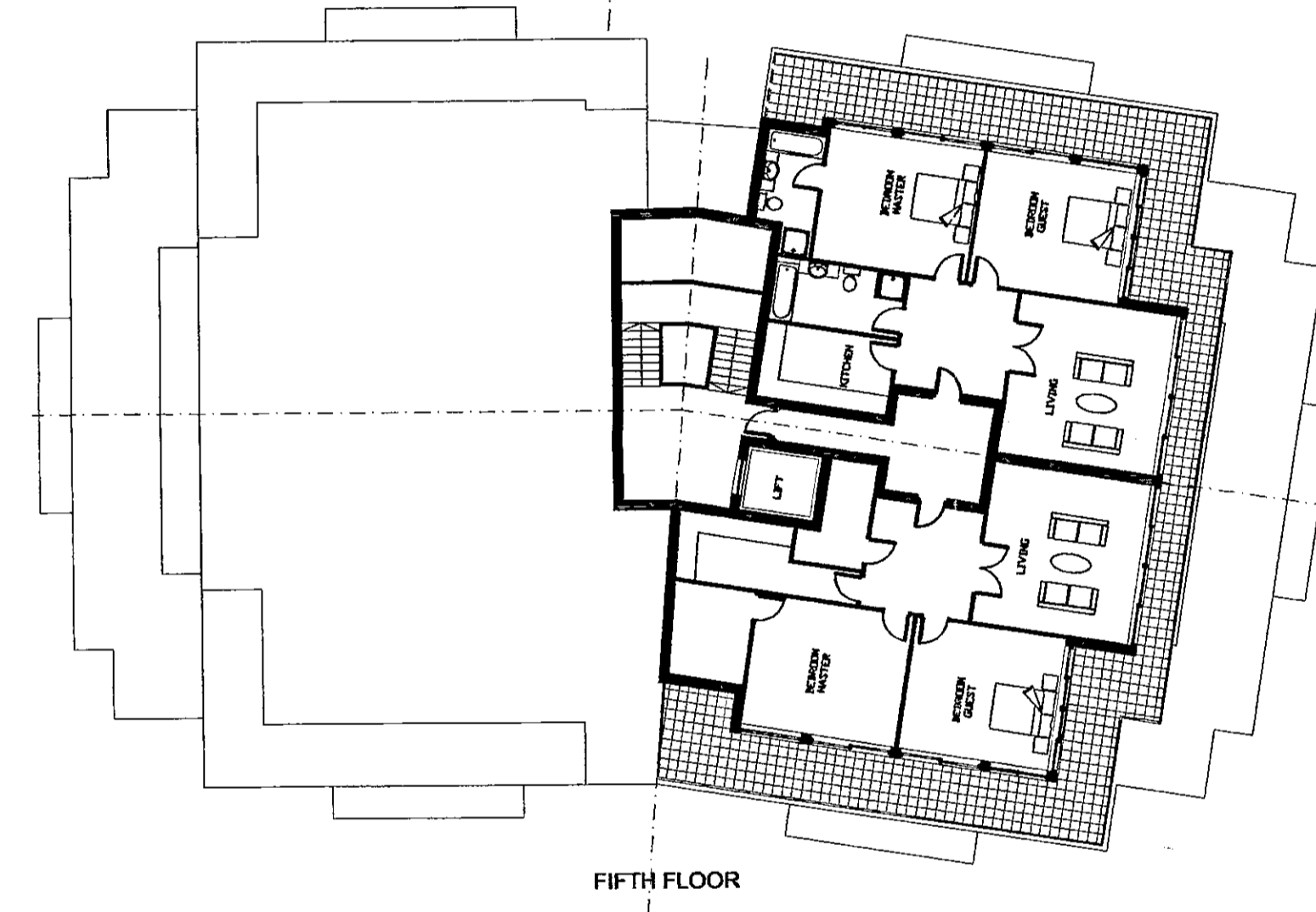

FIFTH FLOOR

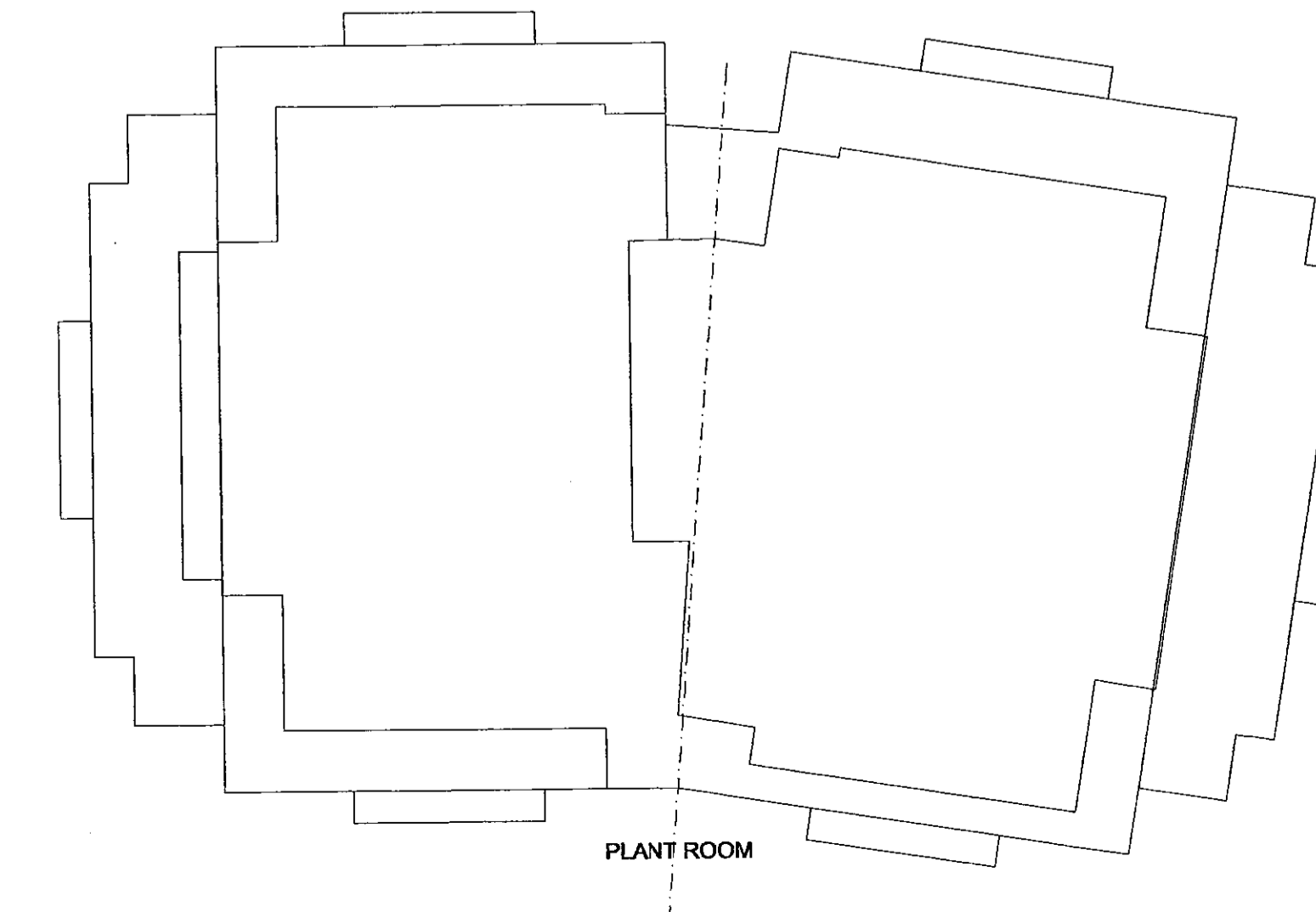

PLANT ROOM

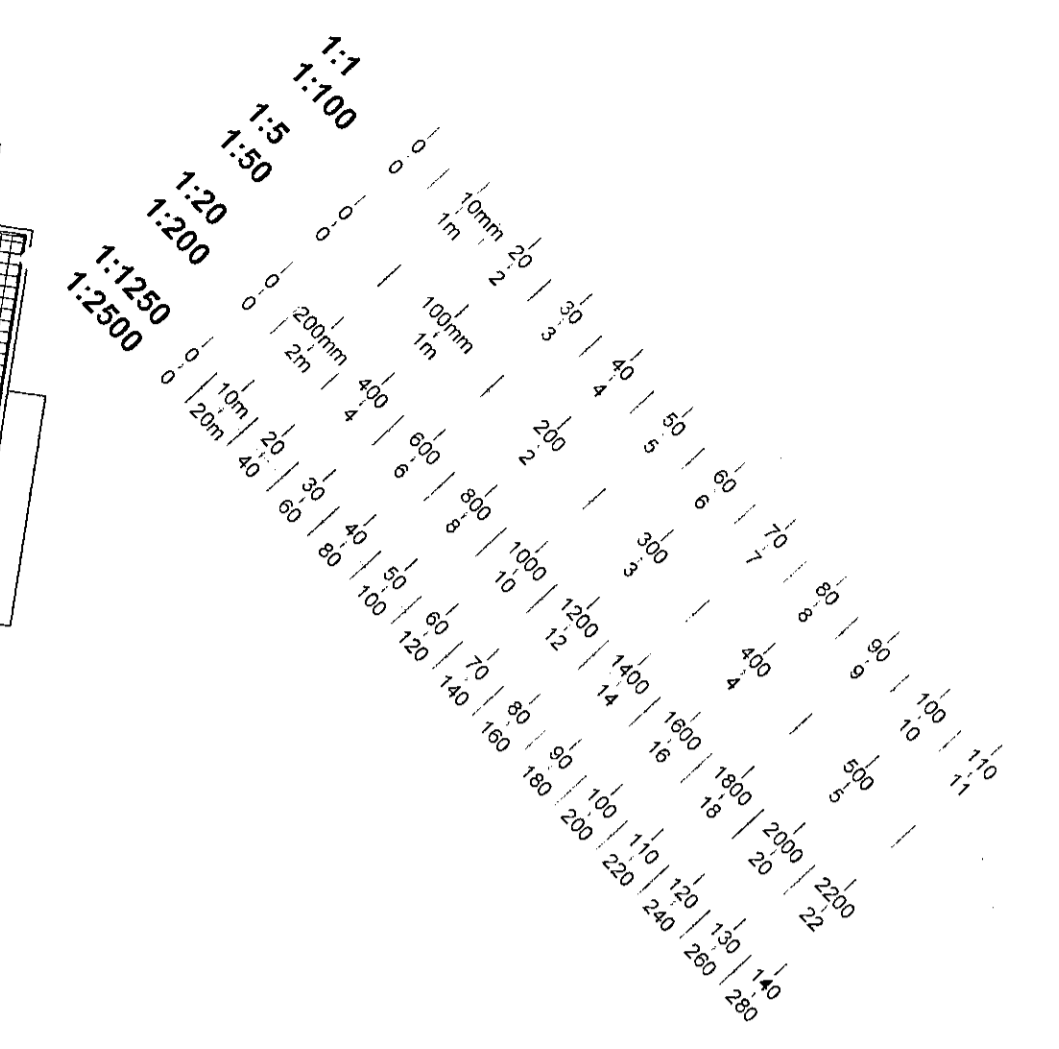

RECEIVED
22 MAR 1999
TOWN PLANNING
R.B.K. & C.

REVISIONS
A: Plans and elevations updated 16/3/99.

P19910733
REFUSED BY
PLANNING SERVICES CT L.L.E.
8 JUN 1998
REFUSAL REF.

BROADWAY MALYAN ARCHITECTS

Broadway Malyan Chartered Architects
Weybridge: Woburn Hill, Addlestone
Weybridge, Surrey KT15 2QA
Telephone 01932 845599 Fax 01932 856206
London: 85 Tottenham Court Road
London W1P 9HD
Telephone 0171 580 5999 Fax 0171 580 8464
Reading: Ilex House, 10 High Street
Theale, Reading, Berkshire RG7 5AN
Telephone 01189 323456 Fax 01189 932461
Southampton: 8 Southampton Street
Southampton, Hampshire SO15 2ED
Telephone 01703 330808 Fax 01703 330986

Aubrey Walk
Campden Hill Reservoir

St James Homes

Campden Hill Flats
Plans & Elevations

Scale	Date	Drawn
1:200	02/11/98	AC
Job No	Drawing No	Revision
7650	P111	A

Original size 100mm Broadway Malyan @ Copyright