

1

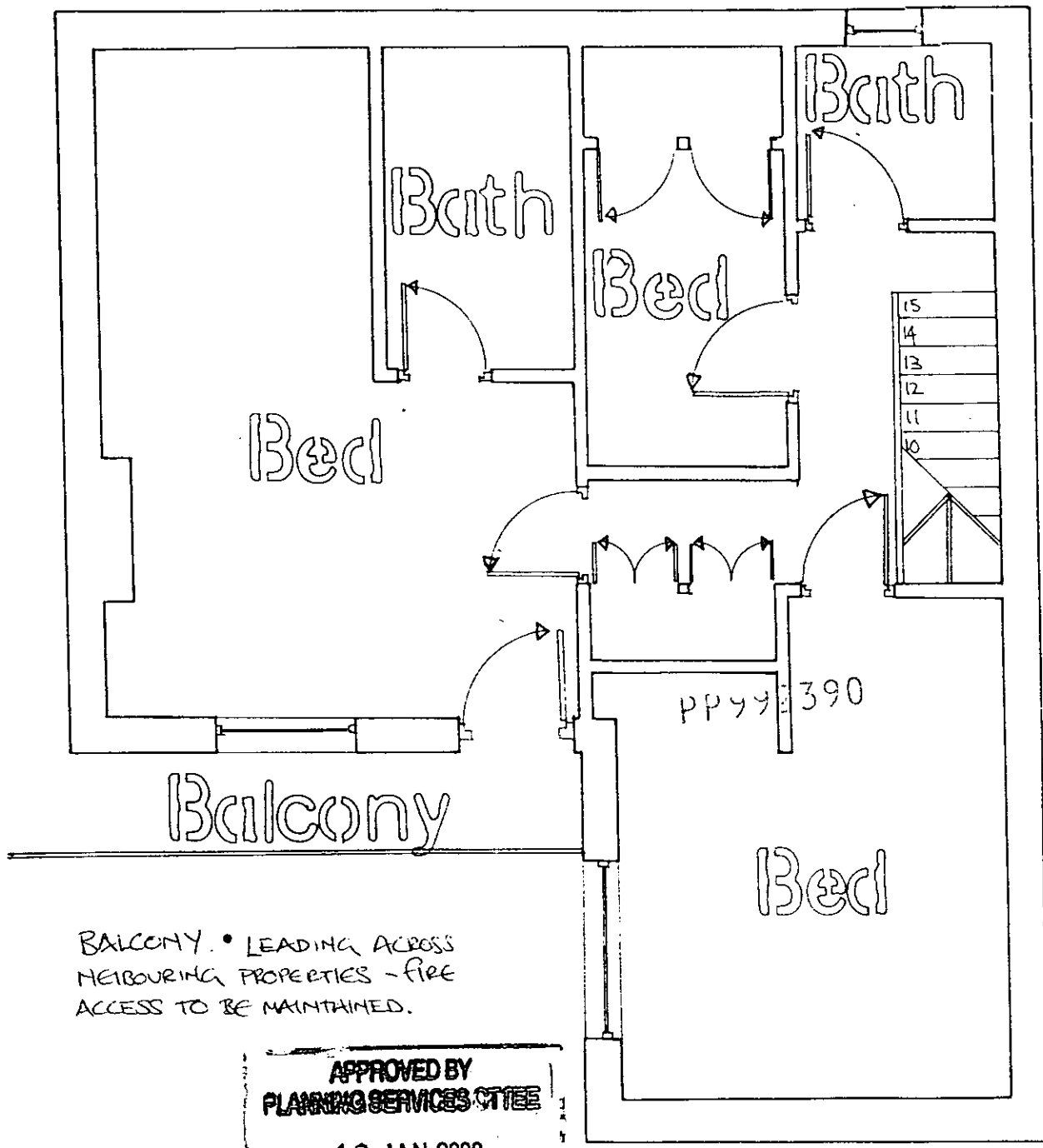

BALCONY • LEADING ACROSS  
 NEIGHBOURING PROPERTIES - FIRE  
 ACCESS TO BE MAINTAINED.

**APPROVED BY**  
**PLANNING SERVICES CTTEE**  
 19 JAN 2000  
 CONSENT REF. \_\_\_\_\_

First Floor  
 Plan  
 Existing

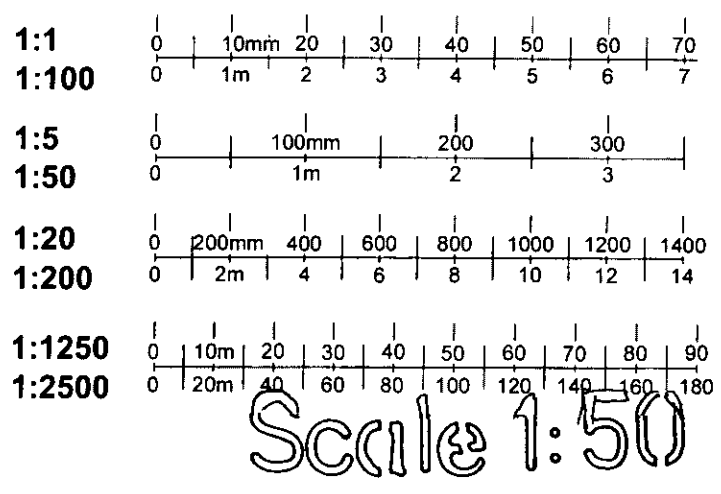

2

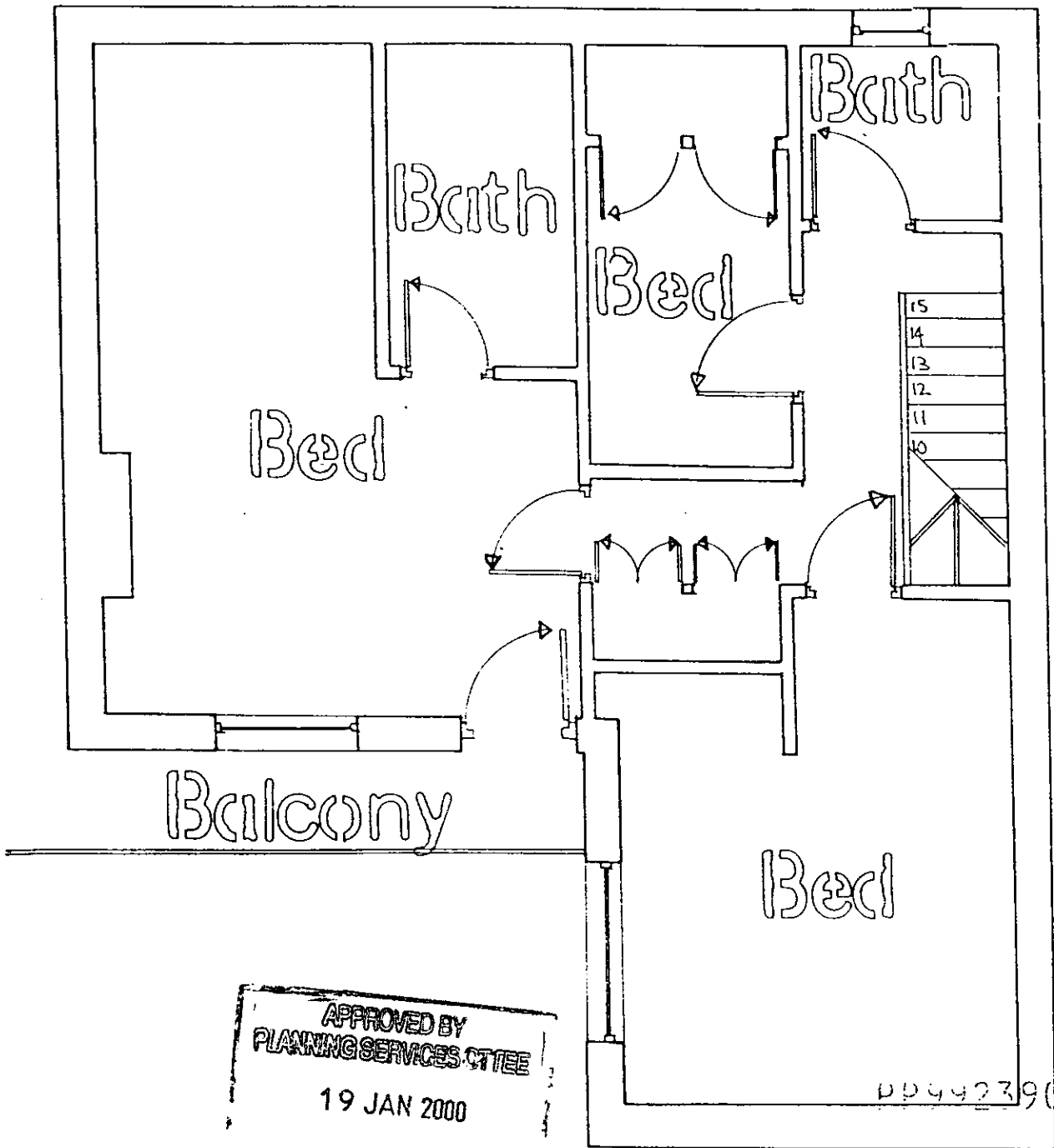

APPROVED BY  
 PLANNING SERVICES CTTEE  
 19 JAN 2000

CONSENT REF. /

First Floor  
 Plan  
 Unciltered

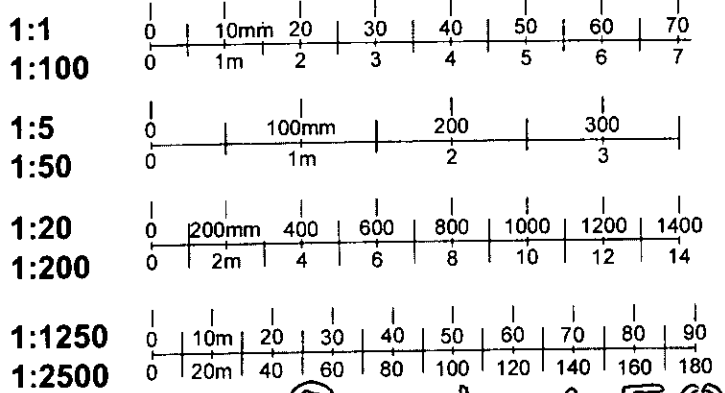

Scale 1:50

13

3

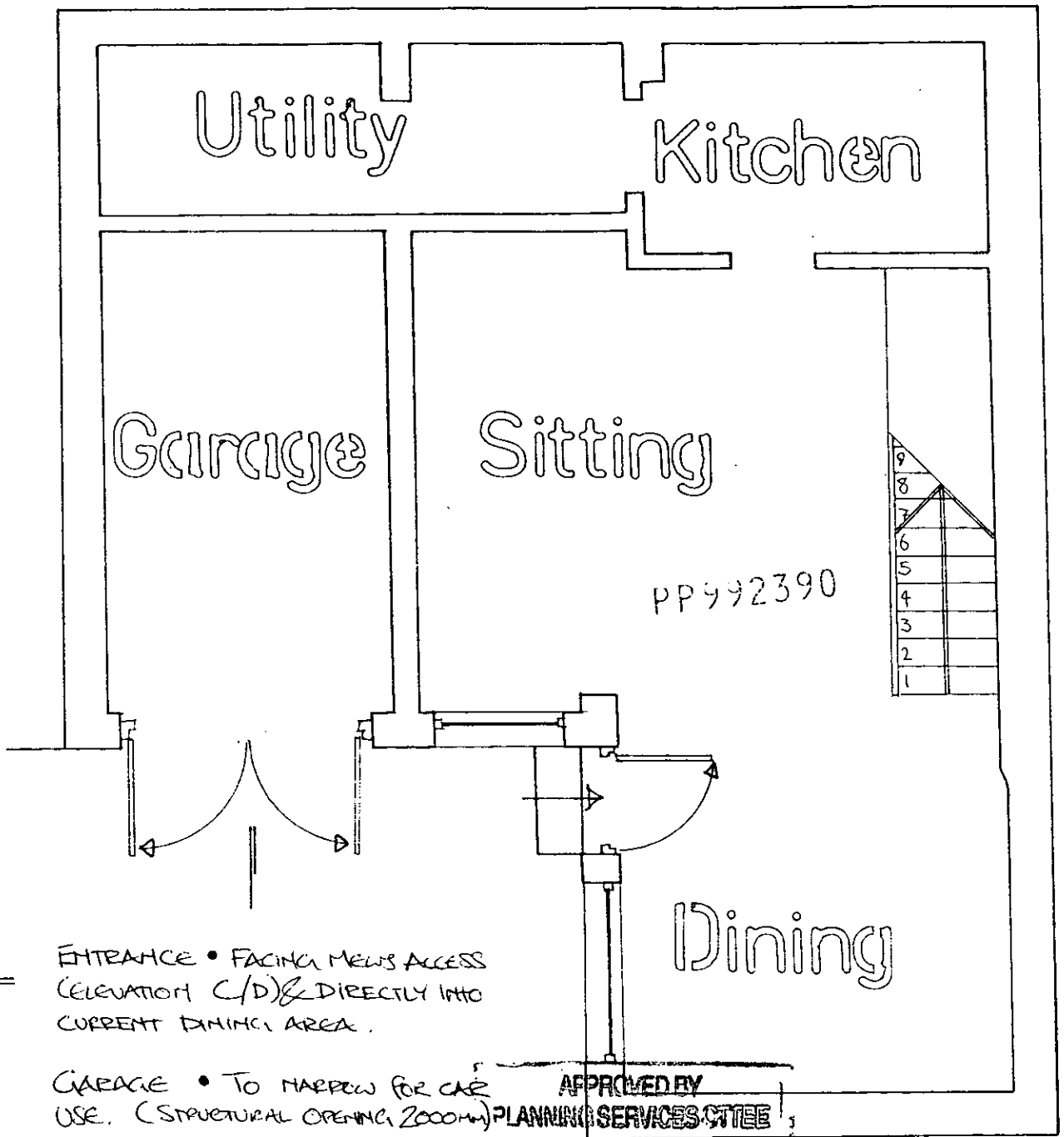

Ground Floor  
Plan  
Existing

1:1	0   10mm   20   30   40   50   60   70
1:100	0   1m   2   3   4   5   6   7
1:5	0   100mm   200   300
1:50	0   1m   2   3
1:20	0   200mm   400   600   800   1000   1200   1400
1:200	0   2m   4   6   8   10   12   14
1:1250	0   10m   20   30   40   50   60   70   80   90
1:2500	0   20m   40   60   80   100   120   140   160   180

Scale 1:50

1:1  
1:100  
1:5  
1:50

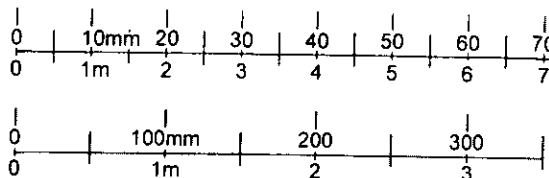

4

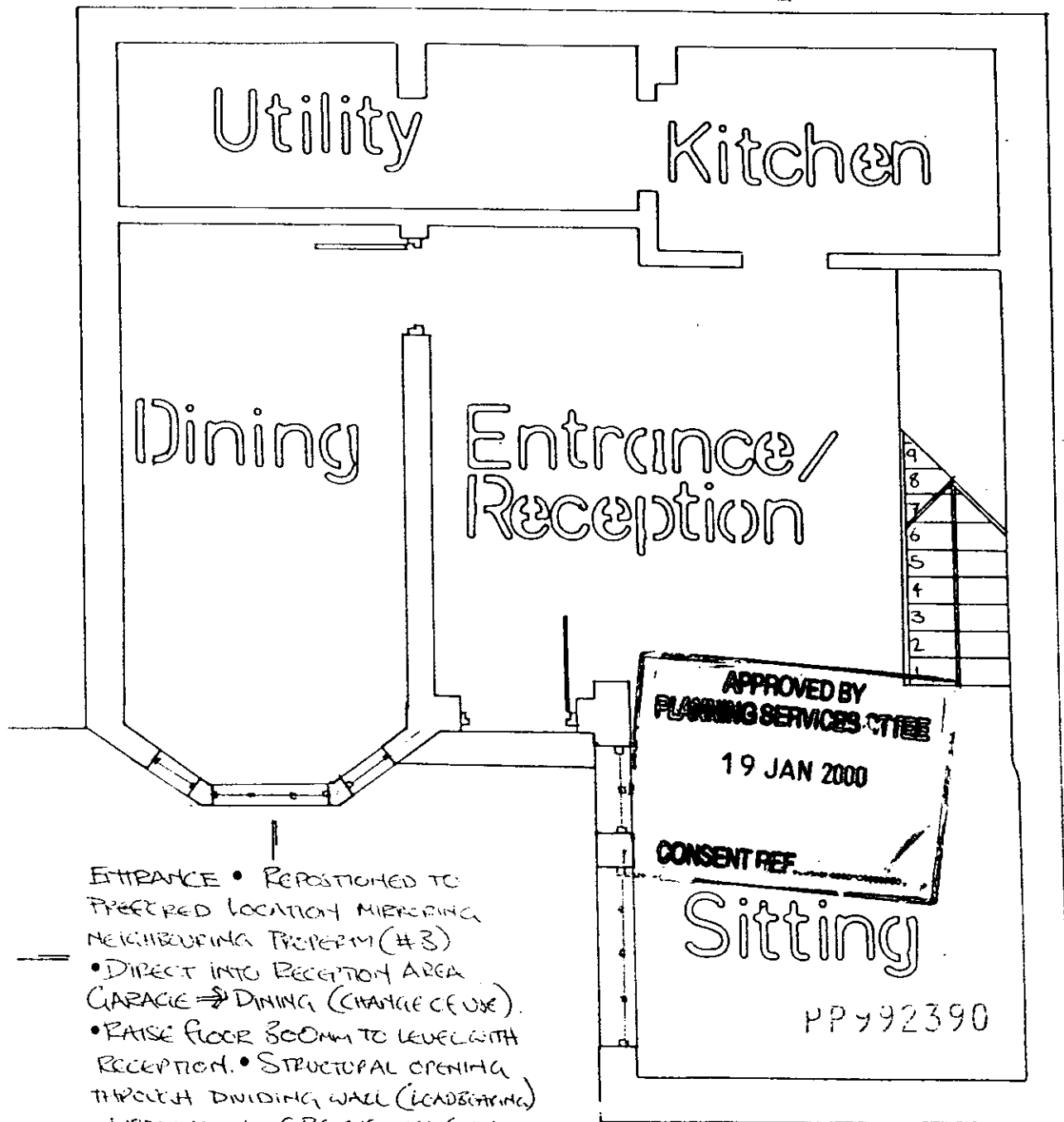

- ENTRANCE • REPOSITIONED TO PREFERRED LOCATION MIRRORING NEIGHBOURING PROPERTY (#3)
- DIRECT INTO RECEPTION AREA GARAGE ⇒ DINING (CHANGE OF USE)
- RAISE FLOOR 300MM TO LEVEL WITH RECEPTION. • STRUCTURAL OPENING THROUGH DIVIDING WALL (LOADBEARING) - INSTALLATION OF REINFORCED CONCRETE LINTEL (CBS).
- BAY WINDOW - INCREASE LIGHT ENTERING ROOM - INCREASE FLOOR AREA (+600MM) - RESPECTING ADJOINING PROPERTY (#5)
- INTRODUCE STAIR FOR DUTYING SERVICE METRES (ELEVATIONS #1, #2)

Ground Floor  
Plan  
Proposed

R.B.K. & C.  
TOWN PLANNING  
- 3 SEP 1999  
RECEIVED

Scale 1:50

5

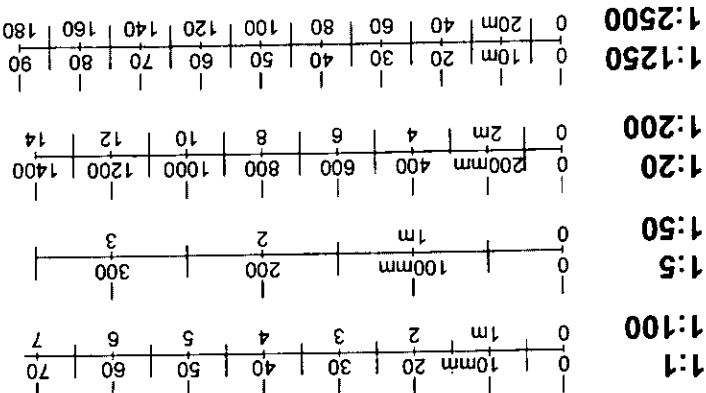
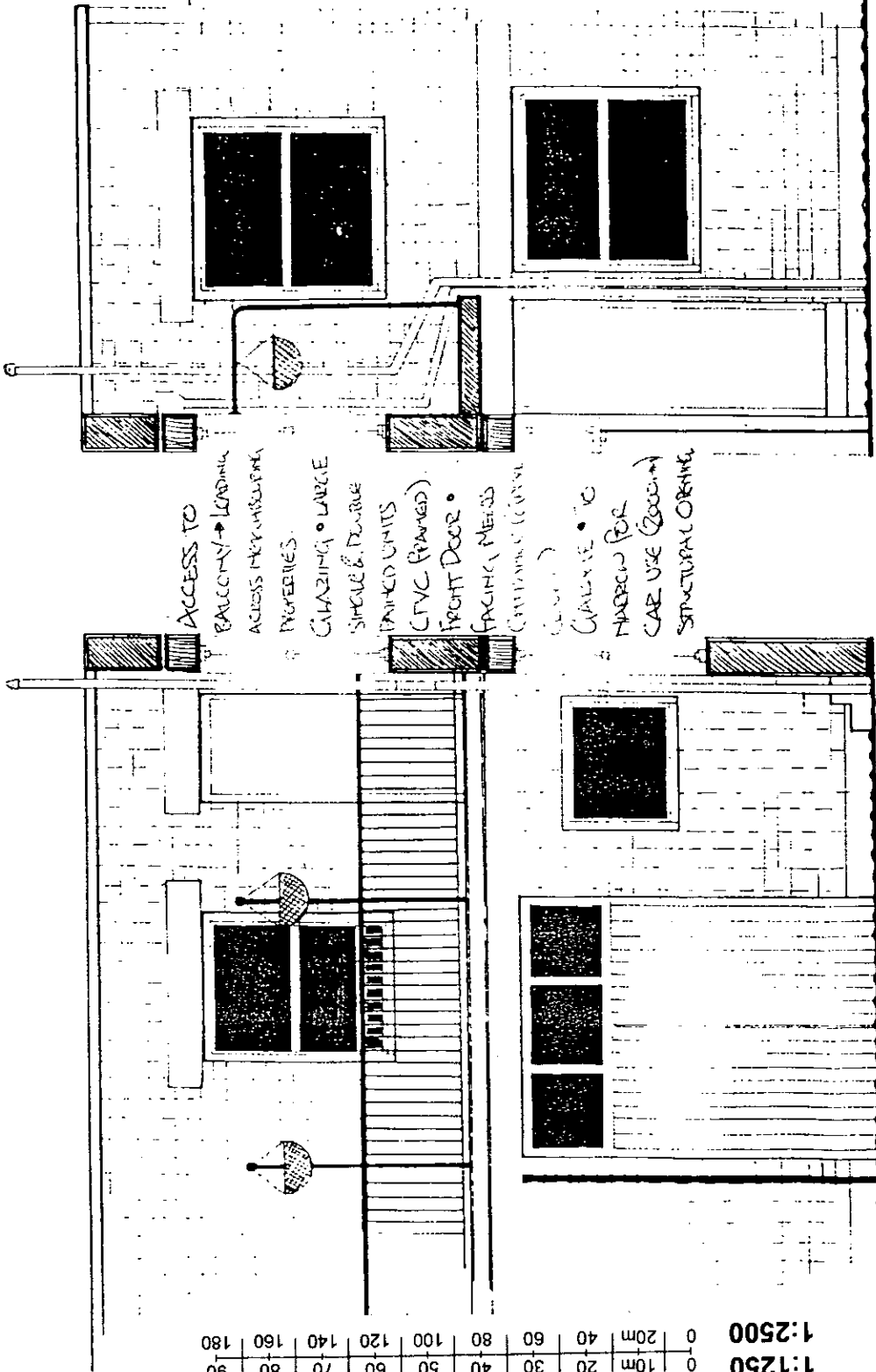

Sectional  
Elevations  
Existing

A

PP992390

R.B.K. & C.  
TOWN PLANNING  
- 3 SEP 1999  
RECEIVED

B

APPROVED BY  
PLANNING SERVICES CTTEE

19 JAN 2000

Scale 1:50

CONSENT REF.

6

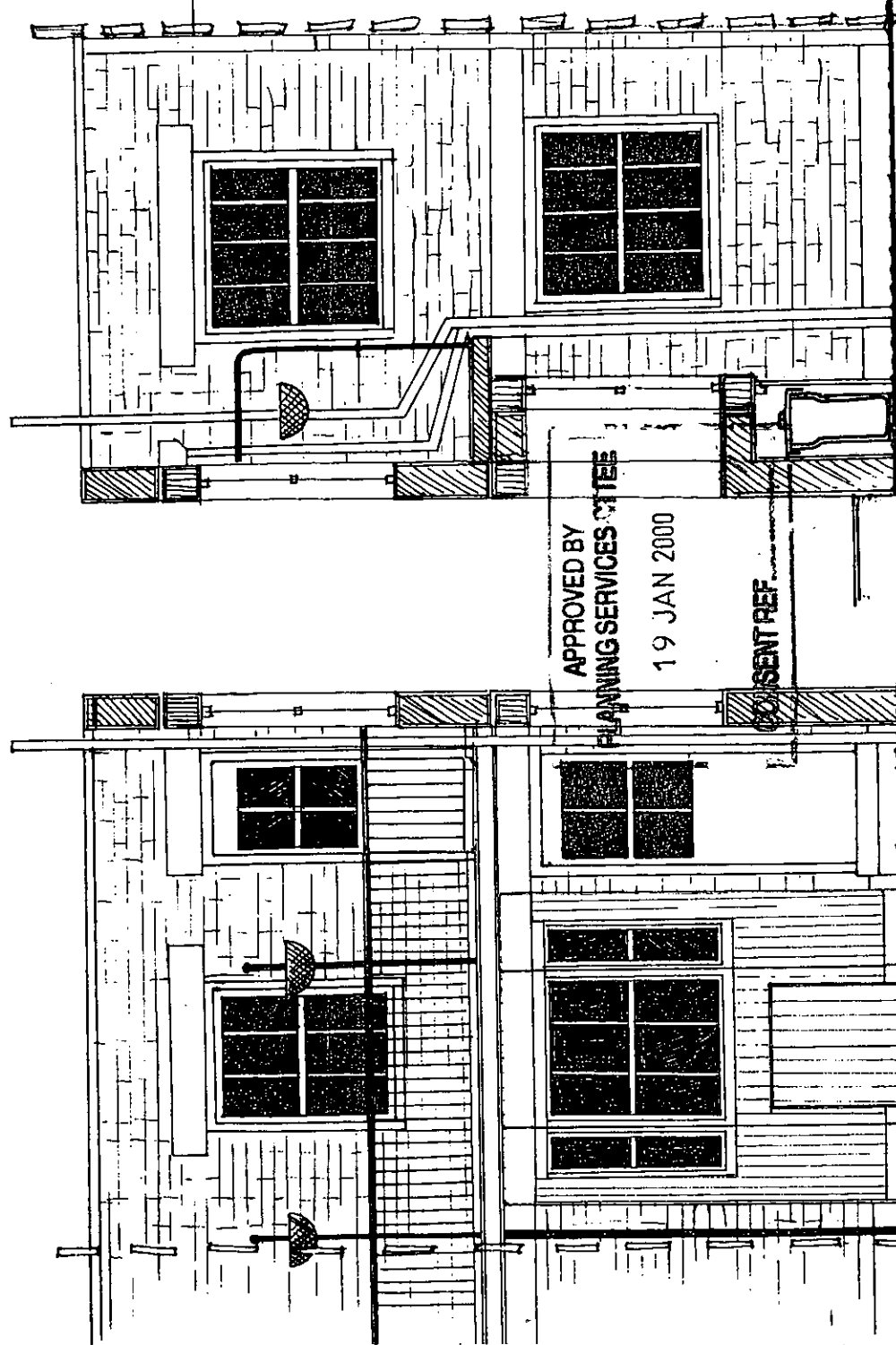

B

BAY TO BE TIMBER STUD WORK,  
INSULATED AND DAMP PROOFED.  
CLAD - TONGUE & GROOVE - WHITE  
RENDER.  
FIRST FLOOR POOR CLAZING  
TO BE CHANGED TO 4 PANELS  
FROM 6.

A

Sectional /  
Elevations  
Proposed / REVISED.

PP/99/2390/A Scale 1:50

4-4a HOLLY MEWS  
OFF DRAUGHTY COPS  
SOUTH CENSINGTON  
SW10 9RS.

0	10m	20	30	40	50	60	70	80	90	1:100
0	100mm	200	300	400	500	600	700	800	900	1:100
0	1m	2	3	4	5	6	7	8	9	1:100
0	200mm	400	600	800	1000	1200	1400	1600	1800	1:200
0	2m	4	6	8	10	12	14	16	18	1:200
0	10m	20	30	40	50	60	70	80	90	1:1250
0	20m	40	60	80	100	120	140	160	180	1:2500

R.B.K.&C.  
TOWN PLANNING  
10 JAN 2000  
RECEIVED

4-4a HOLLY MEWS  
OFF DRAUGHTON COBNS  
SOUTH CENSINGTON  
SW10 9RS.

Sectional I  
Elevations  
Proposed / Revised.

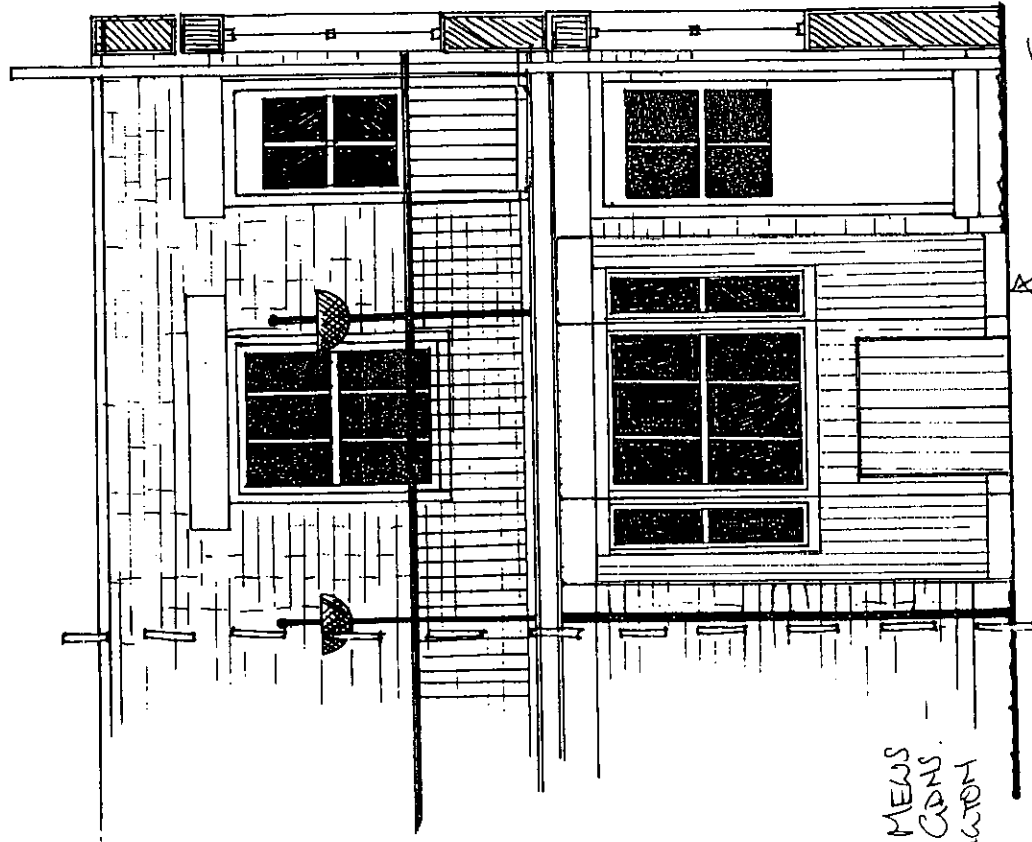

A

BAY TO BE TIMBER STUD WORK,  
INSULATED AND DAMP PROOFED.  
CLAD - TONGUE & GROOVE - WHITE  
RENDER.  
FIRST FLOOR DOOR GLAZING  
TO BE CHANGED TO 4-PANELS  
FROM 6.

PP/99/2390/A Scale 1:50

B

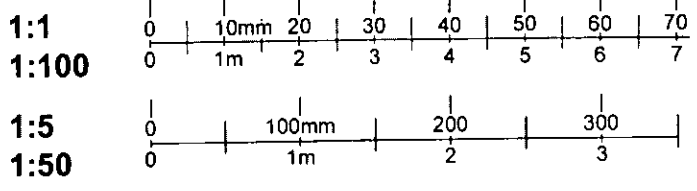
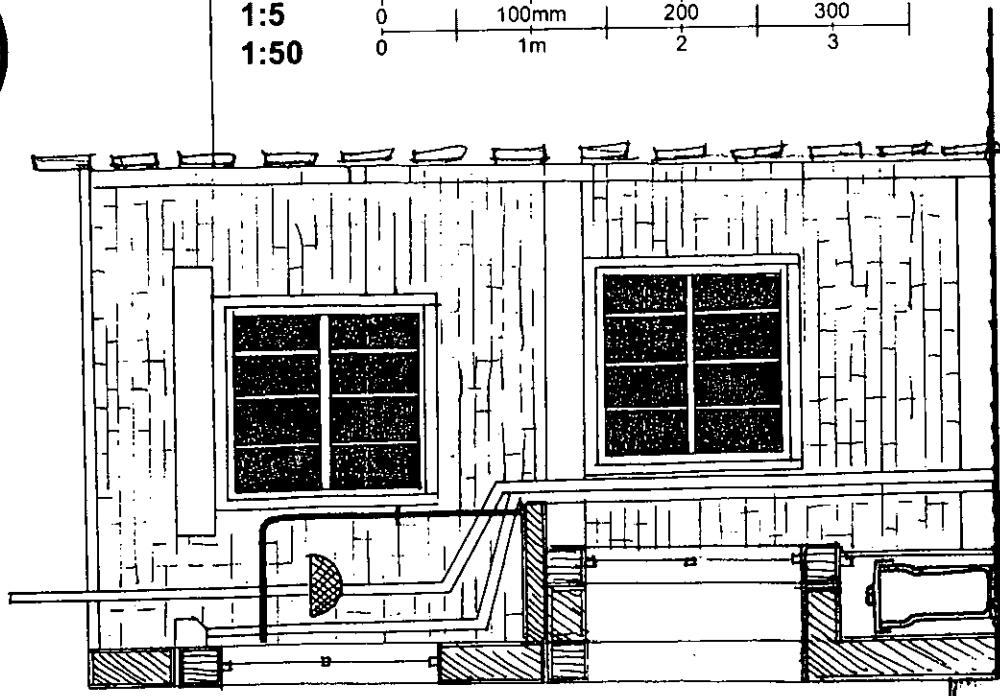

7